



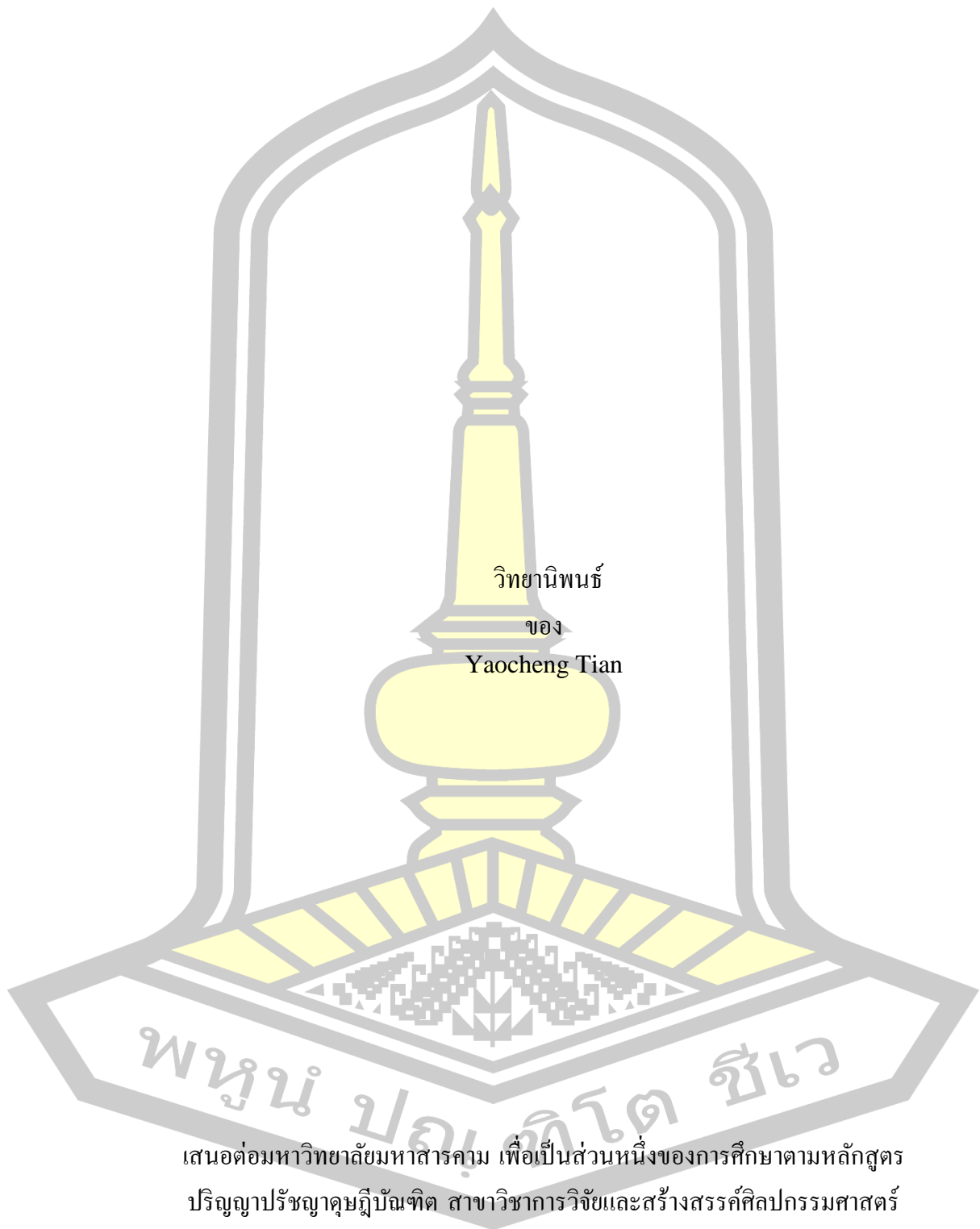
Guangxi Zhuang Brocade: Social Memory and Traditional Invention in the Context of
China's Reform and Opening-Up

Yaocheng Tian

A Thesis Submitted in Partial Fulfillment of Requirements for
degree of Doctor of Philosophy in Fine and Applied Arts Research and Creation
August 2024

Copyright of Maharakham University

ความทรงจำทางสังคม และการประดิษฐ์แบบดั้งเดิมในบริบทของการปฏิรูป และการเปิดตัวของจีน



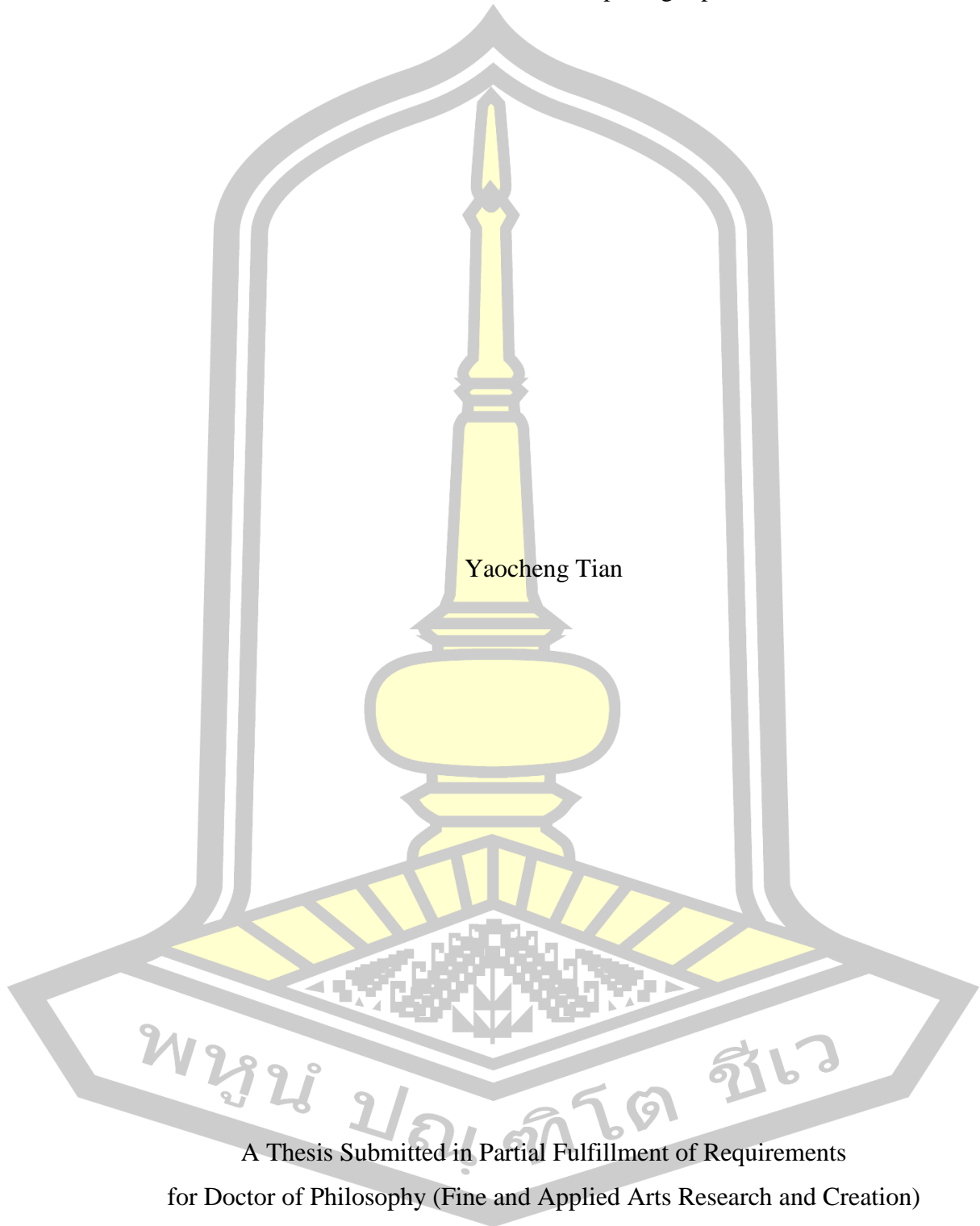
วิทยานิพนธ์
ของ
Yaocheng Tian

เสนอต่อมหาวิทยาลัยมหาสารคาม เพื่อเป็นส่วนหนึ่งของการศึกษาตามหลักสูตร
ปริญญาปรัชญาดุษฎีบัณฑิต สาขาวิชาการวิจัยและสร้างสรรค์ศิลปกรรมศาสตร์

สิงหาคม 2567

ลิขสิทธิ์เป็นของมหาวิทยาลัยมหาสารคาม

Guangxi Zhuang Brocade: Social Memory and Traditional Invention in the Context of
China's Reform and Opening-Up



Yaocheng Tian

A Thesis Submitted in Partial Fulfillment of Requirements
for Doctor of Philosophy (Fine and Applied Arts Research and Creation)

August 2024

Copyright of Mahasarakham University



The examining committee has unanimously approved this Thesis, submitted by Mr. Yaocheng Tian , as a partial fulfillment of the requirements for the Doctor of Philosophy Fine and Applied Arts Research and Creation at Mahasarakham University

Examining Committee

Chairman

(Li Yingfeng , Ph.D.)

Advisor

(Assoc. Prof. Sakchai Sikka , Ph.D.)

Committee

(Assoc. Prof. Prathabjai Suwanthada , Ph.D.)

Committee

(Asst. Prof. Peera Phanlukthao , Ph.D.)

Committee

(Assoc. Prof. Arkom Sa-Ngiamviboon , Ph.D.)

Mahasarakham University has granted approval to accept this Thesis as a partial fulfillment of the requirements for the Doctor of Philosophy Fine and Applied Arts Research and Creation

(Asst. Prof. Peera Phanlukthao , Ph.D.)

Dean of Faculty of Fine - Applied Arts and Cultural Science

(Assoc. Prof. Krit Chaimoon , Ph.D.)

Dean of Graduate School

TITLE	Guangxi Zhuang Brocade: Social Memory and Traditional Invention in the Context of China's Reform and Opening-Up		
AUTHOR	Yaocheng Tian		
ADVISORS	Associate Professor Sakchai Sikka , Ph.D.		
DEGREE	Doctor of Philosophy	MAJOR	Fine and Applied Arts Research and Creation
UNIVERSITY	Maharakham University	YEAR	2024

ABSTRACT

The research topic of this paper is Guangxi Zhuang brocade. This paper has four research objectives: 1.To study the historical, social and cultural background of Guangxi Zhuang Brocade. 2.To study and analyze the "social memory" of Guangxi Zhuang Brocade before and after the reform and opening up. 3. To study and analyze the "traditional invention" of Guangxi Zhuang Brocade after the reform and opening up.4. To study and analyse the social memory and traditional invention of Zhuang brocade in Guangxi through folk activities in the context of China's reform and opening up.

Under the background of comprehensive reform and open to the outside world and in-depth development of intangible cultural heritage protection cause, Guangxi Zhuang brocade, as the unique folk art and folk culture of the Zhuang people in China, has become an important bond to promote the unity of all ethnic groups in Guangxi. Zhuang brocade Culture has profound cultural connotation and historical value. The research in this paper will help to inherit and develop Zhuang brocade culture, enhance the good belief of compatriots of all ethnic groups in Guangxi to pursue a happy life, form a good social atmosphere, and maintain social stability. This is of great practical significance to the cultural inheritance of ethnic minorities in Guangxi.

First, this paper starts with the specific geographical environment and cultural environment of Guangxi Zhuang brocade, and analyzes the origin, development and artistic culture of Zhuang brocade.

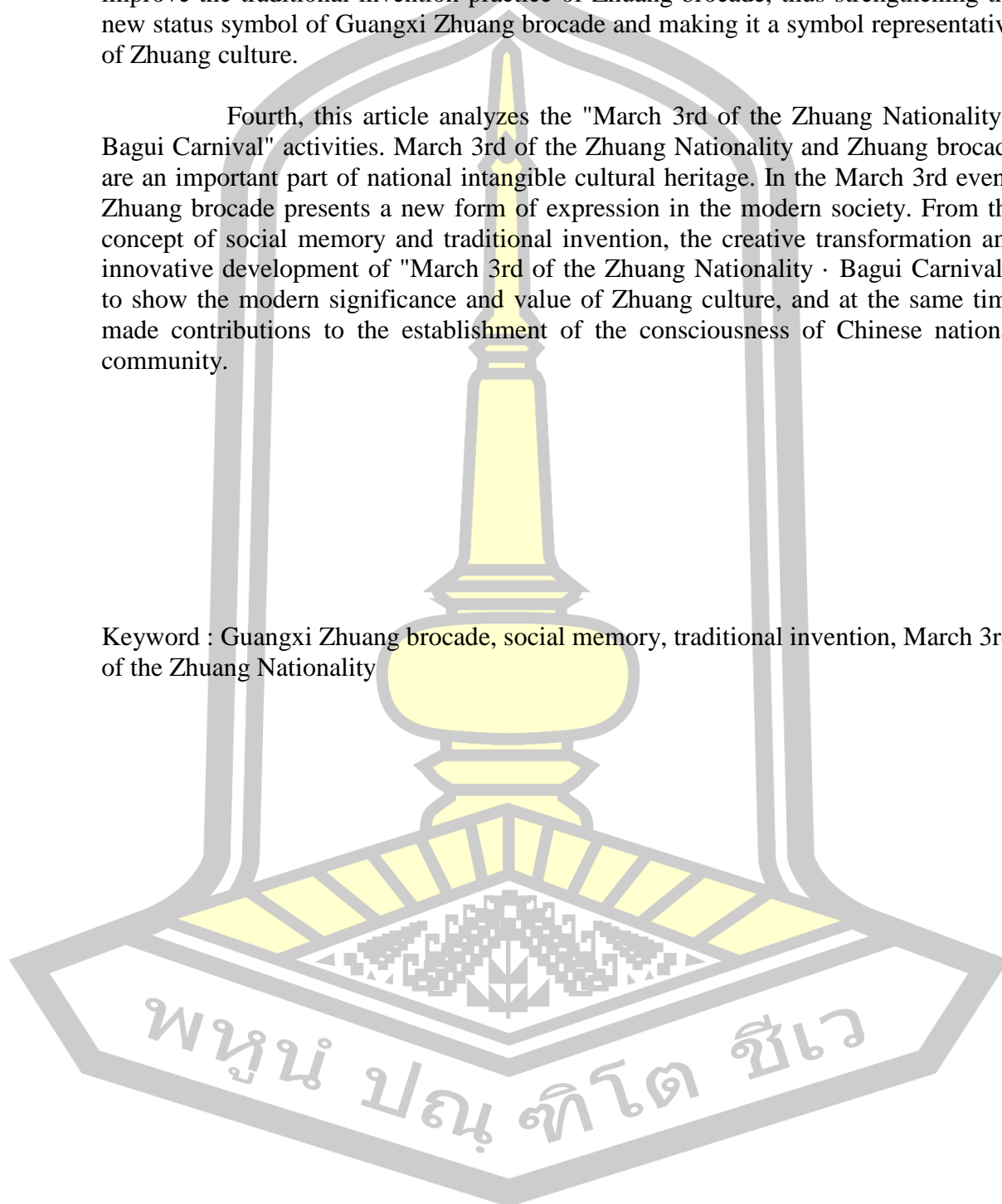
Secondly, this paper starts with the literature and legends about Guangxi Zhuang brocade, analyzes and enumerates the social memory information retained in totem and belief, life ceremony, daily life and inheritance in Zhuang brocade, and discusses the symbolic significance of Guangxi Zhuang brocade as a symbol of Zhuang culture.

Thirdly, this paper analyzes the construction process and mode of Guangxi Zhuang brocade after reform and open to the outside world from the

perspective of traditional invention. It also discusses the influence of government shaping, giant Zhuang brocade, technological invention and pattern invention on contemporary Guangxi Zhuang brocade. Some suggestions are put forward to improve the traditional invention practice of Zhuang brocade, thus strengthening the new status symbol of Guangxi Zhuang brocade and making it a symbol representative of Zhuang culture.

Fourth, this article analyzes the "March 3rd of the Zhuang Nationality · Bagui Carnival" activities. March 3rd of the Zhuang Nationality and Zhuang brocade are an important part of national intangible cultural heritage. In the March 3rd event, Zhuang brocade presents a new form of expression in the modern society. From the concept of social memory and traditional invention, the creative transformation and innovative development of "March 3rd of the Zhuang Nationality · Bagui Carnival", to show the modern significance and value of Zhuang culture, and at the same time made contributions to the establishment of the consciousness of Chinese national community.

Keyword : Guangxi Zhuang brocade, social memory, traditional invention, March 3rd of the Zhuang Nationality



ACKNOWLEDGEMENTS

During my study in Thailand, it was like a dreamlike journey. I was immersed in this exotic country and felt its unique cultural charm and profound Buddhist tradition. Here, every moment is full of exploration and harvest, is a very precious experience in my life.

When I first arrived in Thailand, I was very curious about everything. From the bustling city to the quiet countryside, from the unique food to the traditional festivals, I enjoy the diversity and inclusiveness of this country. What is even more precious is that I have met so many talented and thoughtful mentors and friends here.

Thanks to my tutor, Professor Sakchai sikka, who is not only knowledgeable, but also sincere to others. His noble quality and rigorous research attitude have deeply influenced me. Under his guidance, I not only improved my academic level, but also learned how to treat life and others. At the same time, I would also like to thank all the teachers of the college for giving me a lot of help. They recommended many world-leading academic works to me, so that I could use anthropology and sociological thinking to study art.

In addition, I would also like to thank Dr. Yang Na for her care and support, and those friends who have met in Thailand. Their company makes my life more colorful, and I benefit from every communication and study a lot.

I will always cherish this good memory. The learning time in Thailand makes me deeply realize the colorful and richness of life. I not only learned knowledge, but also gained the wisdom of friendship and life. In the coming days ahead, I will turn this experience into motivation to move forward and explore a wider world.

พูน ปณ ทิโต ชีเว

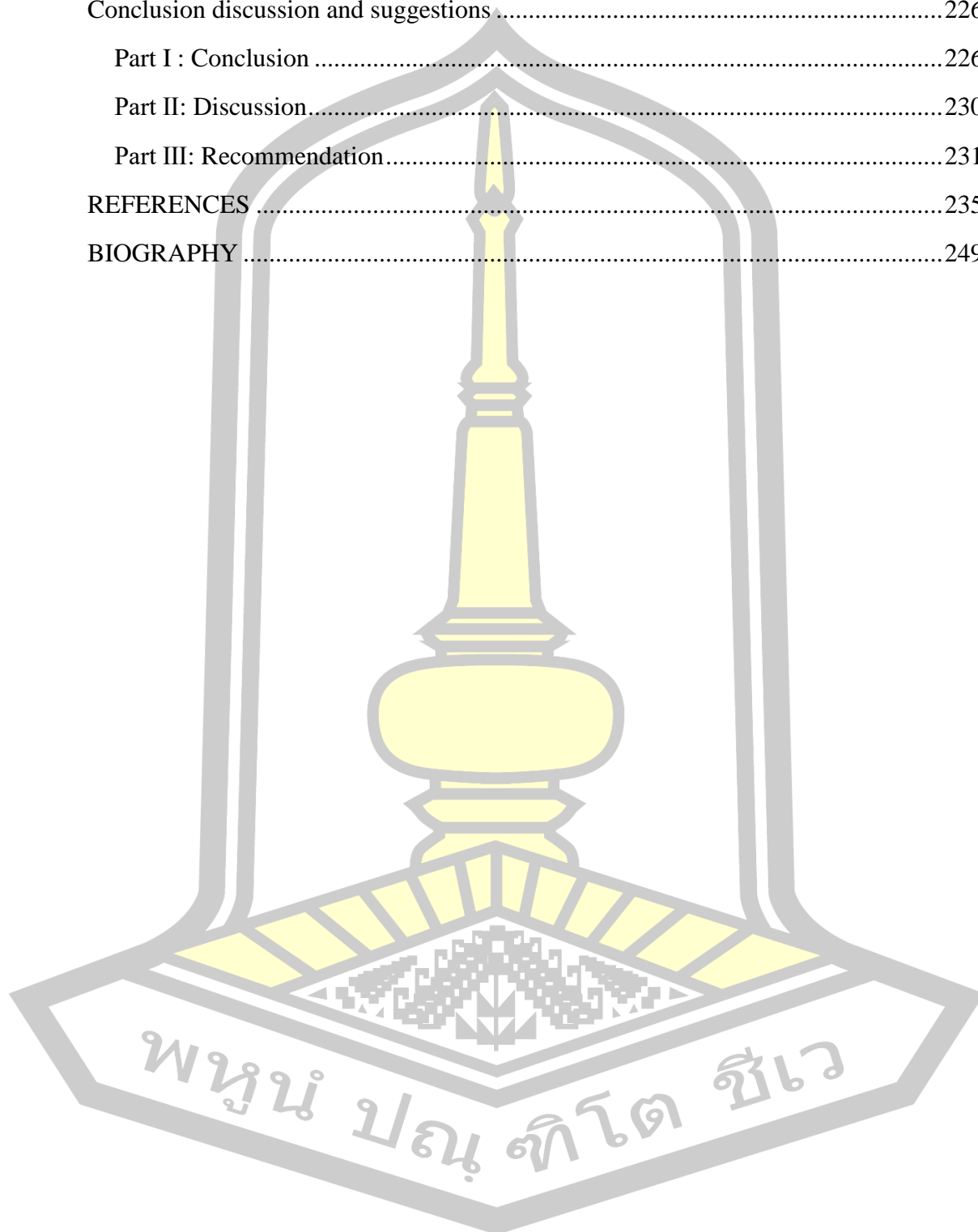
Yaocheng Tian

TABLE OF CONTENTS

	Page
ABSTRACT.....	D
ACKNOWLEDGEMENTS.....	F
TABLE OF CONTENTS.....	G
LIST OF TABLES.....	J
LIST OF FIGURES.....	K
CHAPTER I.....	1
Introduction.....	1
1. Background of Research.....	1
2. Purpose of the Research.....	7
3. Research questions.....	7
4. Definition of Terms/ Concise/ More Compact.....	7
5. Scope of Research.....	9
6. Research Methodology.....	11
7. Data collection.....	11
8. Scope of Research.....	13
9. Literature review.....	14
10. Research plan.....	30
11. Benefits of Research.....	31
CHAPTER II.....	32
Guangxi Zhuang brocade Historical and artistic value.....	32
Part I: Guangxi Zhuang brocade Production area environment, and the production process.....	32
Part II: Guangxi Zhuang brocade History and development.....	42
Part III: Guangxi Zhuang brocade, Cultural and art analysis.....	63
Summary.....	71
CHAPTER III.....	73

The social memory of the Guangxi Zhuang brocade.....	73
Part I: Guangxi Zhuang brocade, The social memory in the historical literature....	73
Part II: Guangxi Zhuang brocade, The social memory of Chinese totem and faith	94
Part III: Guangxi Zhuang brocade The social memory in the ritual of life	109
Part IV: Guangxi Zhuang brocade, social memory in daily life	115
Part V: Guangxi Zhuang brocade The social memory in the inheritance.....	119
Summary.....	132
CHAPTER IV.....	134
Guangxi Zhuang brocade "traditional invention" in China reform and open to the outside world process.....	134
Part I: The analysis of the government in shaping the zhuang cultural symbol Guangxi Zhuang brocade	135
Part II: The creation of "giant" Guangxi Zhuang brocade and the influence of —— Guangxi Zhuang brocade have become the "traditional invention" of Zhuang cultural symbols.....	150
Part III: A "traditional invention" analysis of the Guangxi Zhuang brocade technique.....	157
Part IV: Guangxi Zhuang brocade A "traditional invention" analysis of patterns and patterns	170
Part V: Guangxi Zhuang brocade The "traditional invention" practical exploration	193
Summary.....	196
CHAPTER V	198
Explore the social memory and traditional invention of Guangxi Zhuang brocade through folk activities	198
Part I: Activity background	198
Part II: Nature of the operation.....	201
Part III:Data analysis.....	211
Part IV:Evaluation and discussion.....	218
Part V:propose	221
Summary.....	223

CHAPTER VI.....	226
Conclusion discussion and suggestions.....	226
Part I : Conclusion.....	226
Part II: Discussion.....	230
Part III: Recommendation.....	231
REFERENCES.....	235
BIOGRAPHY.....	249



LIST OF TABLES

	Page
Table 1	39
Table 2 brocadexi Zhuang brocade factory brocade process	41
Table 3 Evolution diagram of brocade diamond pattern	46
Table 4 Establishment statistics of Zhuang brocade Factory in Guangxi region	54
Table 5 In 1985, Binyang national brocade factory, two factory brilliant achievements	58
Table 6 The production value of Zhuang brocade in the whole area in 1979-1995 ...	60
Table 7 Statistical table of product quantity and pattern of transport department brocadeyuan	76
Table 8 Brocade inheritance lineage of Li Suying Family, Shuangmeng Village, brocadelong Town, Longzhou	121
Table 9 Binyang Zhuang brocade inherits the relationship inheritance lineage	126
Table 10 Inheritance pedigree of brocadexi brocade (the author arranges according to the data provided by Zhuang brocade Factory)	130
Table 11 Zhuang brocade art national and district level intangible cultural heritage protection Source: Yaocheng Tian, Author: 17/January/2024.....	146
Table 12 Traditional Guangxi Zhuang brocade loom classification.....	158
Table 13 Statistical table of traditional Zhuang brocade patterns.....	174
Table 14 Zhuang brocade geometric pattern statistical table.....	177
Table 15 Zhuang brocade, statistical table of plant patterns.....	180
Table 16 Zhuang brocade, animal pattern statistics table	184
Table 17 Zhuang brocade, text pattern statistical table.....	186
Table 18 Zhuang brocade, innovative pattern statistical table.....	191
Table 19 Information table of March 3rd of the Zhuang Nationality · Bagui Carnival activities over the years Source : Yaocheng Tian ,Author : 17 / October / 2023....	214

LIST OF FIGURES

	Page
Figure 1 studies the conceptual framework	10
Figure 2 Climate Distribution map of Guangxi	33
Figure 3 Group photo with the director of brocade Guangxi Zhuang brocade Factory	35
Figure 4 Binyang County National brocade Factory	37
Figure 5 Organization structure of Zhuang brocade	42
Figure 6 Organization structure of Zhuang brocade	42
Figure 7 "Black ground orange back grain brocade" unearthed from the No.1 tomb of Robo Bay	44
Figure 8 Line draft of textile tools unearthed from the No.1 Tomb of Robo Bay	44
Figure 9 Zhuang brocade is collected in the Palace Museum of the Qing Dynasty ...	49
Figure 10 Zhuang brocade: Song and Dance Weaving Dream.....	69
Figure 11 Statistical table of Guangxi brocade officials.....	78
Figure 12 Zhuang people in the Qing Dynasty (one person on the right held Zhuang brocade in his hand)	81
Figure 13 A cartoon poster for "Zhuang brocade"	89
Figure 14 Moman Square, Banhe Village.....	91
Figure 15 The brocade Guangxi Zhuang people worship the "flower woman god" tablet ..	95
Figure 16 Diamond chrysanthemum lines Zhuang brocade strap heart.....	96
Figure 17 Python dragon pattern Zhuang brocade large wall hanging	97
Figure 18 Dragon and phoenix kirin deer chicken pattern Zhuang brocade quilt face core.....	98
Figure 19 Zhuang brocade scroll wall hanging.....	101
Figure 20 Dog totem Zhuang brocade strap heart.....	102
Figure 21 Sun grain Zhuang brocade back belt heart	104
Figure 22 Phoenix flower and tree pattern Zhuang brocade.....	105
Figure 23 Water grain is Zhuang brocade.....	106
Figure 24 Python dragon pattern Zhuang brocade local thunder pattern.....	106

Figure 25 Fire grain Zhuang brocade.....	107
Figure 26 Zhuang brocade with field motifs.....	108
Figure 27 Zhuang traditional back strap	110
Figure 28 The strap is made of zhuang brocade	111
Figure 29 The groom Huang Guozhu and the bride Lu Xiaofang held a traditional wedding.....	112
Figure 30 Phoenix bird wearing flowers Zhuang brocade quilt face	114
Figure 31 Longzhou Zhuang brocade family "five golden flowers" (from the front row: Li Siying, Li Suying, from the back row: Li Siyi, Li Sufen, Li Sufang).....	122
Figure 32 Li Suying instructs her daughter Li Siyi to weave Zhuang brocade	123
Figure 33 Longzhou County Zhuang brocade artists are directing children to weave Zhuang brocade.....	123
Figure 34 Photo of Tian Xiaocheng and Ms.Huang Aiqun (Tian Yicheng the left, Huang Aiqun in the middle, and Huang Peijun on the right)	125
Figure 36 Professor Zhuang brocade pattern of brocadexi Zhuang brocade Factory	127
Figure 37 brocadexi Zhuang brocade factory professor Zhuang brocade weaving flowers.....	127
Figure 38 The Zhuang brocade pattern is discussed in brocadexi Zhuang brocade Factory	128
Figure 39 The process of "traditional invention" of Zhuang brocade in Guangxi from 1978 - 2023	134
Figure 40 Guangxi float actors dressed in ethnic costumes take pictures in front of the mass parade marking the 70th anniversary of the founding of the People's Republic of China in 2019.....	138
Figure 41 Xincheng County doctor Zhuang brocade brocade skills display	141
Figure 42 Xincheng County doctor Zhuang brocade brocade skills display	142
Figure 43 National intangible cultural heritage —— Zhuang brocade technical plaque	144
Figure 44 "Double wind toward the flowers" Zhuang brocade big wall hanging	151
Figure 45 Celebrating the 10th Anniversary of Hong Kong's return" Zhuang brocade big wall hanging.....	151

Figure 46 Guangxi Zhuang brocade for the Expo Zhuang brocade wall hanging....	152
Figure 47 "the largest —— and largest Zhuang brocade in the Guinness World" issued by the Guinness Headquarters in Shanghai	153
Figure 48 "Beautiful Zhuang brocade dedicated to the Party" Zhuang brocade long scroll.....	154
Figure 49 brocadexi brocade machine (traditional type)	159
Figure 50 Binyang bamboo cage machine	160
Figure 51 Structure diagram of the Zhuang brocade loom in the Republic of China period	161
Figure 52 Huanjiang brocade machine	162
Figure 53 Longzhou brocade machine.....	163
Figure 54 Bmachine	165
Figure 55 Bamboo cage machine improved by Wang Zhiqing	166
Figure 56 brocadexi Zhuang brocade loom (improved type)	166
Figure 57 K-84 type 22-400 silk loom.....	167
Figure 58 Silk loom used in Binyang Xiangguang brocade workshop.....	168
Figure 59 Longevity pattern Zhuang brocade.....	171
Figure 60 Display of Guangxi Zhuang brocade in the "March 3rd of the Zhuang Nationality · Bagui Carnival" over the years.....	201
Figure 61 Tan Xiangguang, a master of Chinese arts and crafts, performs the traditional Zhuang brocade manufacturing techniques.....	202
Figure 62 The first China-Asean (Nanning) Intangible Cultural Heritage Week activity Week	203
Figure 63 During the March 3rd of the Zhuang Nationality in 2023, Ms. Tan Xiangguang went to Guangxi University of Mechanical and Electrical Engineering to give a Zhuang brocade topic lecture	204
Figure 64 During the March 3rd of the Zhuang Nationality of 2023, the Fan Lihua girl guided the Zhuang brocade jewelry production.....	205
Figure 65 March 3rd of the Zhuang Nationality · Bagui Carnival in 2018	207
Figure 66 On April 27, 2021, President Xi brocadeping watched the "March 3rd of the Zhuang Nationality", "Song Wei Festival" and other ethnic cultural activities	207

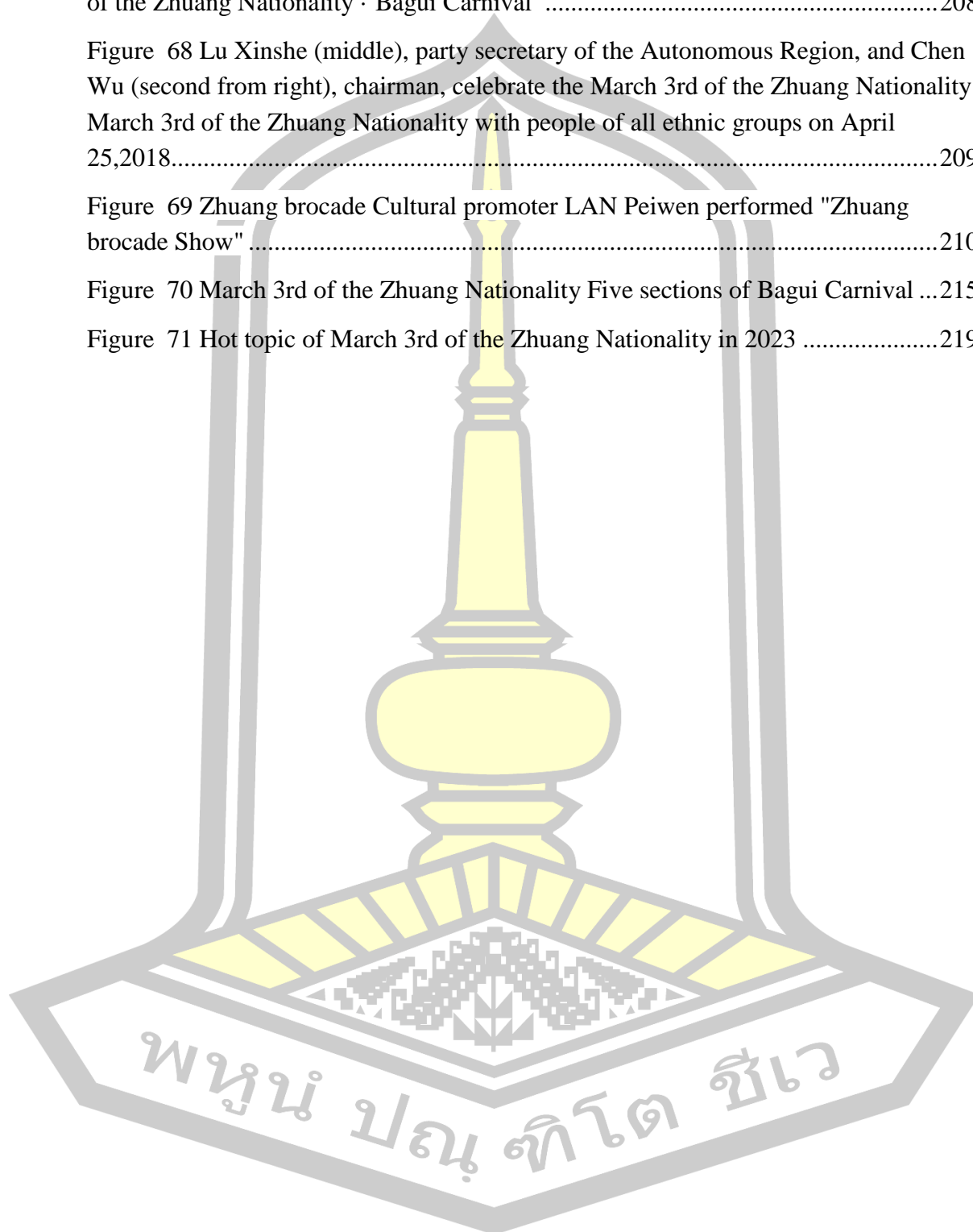
Figure 67 Liu Ning and Sun Dawei attend the opening ceremony of "2023 March 3rd of the Zhuang Nationality · Bagui Carnival"208

Figure 68 Lu Xinshe (middle), party secretary of the Autonomous Region, and Chen Wu (second from right), chairman, celebrate the March 3rd of the Zhuang Nationality March 3rd of the Zhuang Nationality with people of all ethnic groups on April 25,2018.....209

Figure 69 Zhuang brocade Cultural promoter LAN Peiwen performed "Zhuang brocade Show"210

Figure 70 March 3rd of the Zhuang Nationality Five sections of Bagui Carnival ...215

Figure 71 Hot topic of March 3rd of the Zhuang Nationality in 2023219



CHAPTER I

Introduction

1. Background of Research

Brocade is a colored silk thread with flat or oblique multiple or multiple layer tissue, woven into a variety of exquisite pattern textiles. "Brocade" has originated in China with a long history of more than 3,000 years. Under the influence of geographical environment, historical background and different ethnic groups, it has gradually developed into various kinds of brocade. The most representative are the four famous Chinese brocade, namely Yun brocade, Shu brocade, Song brocade and Zhuang brocade. In the minority areas, there are Yao brocade, Dong brocade, Miao brocade, Tujia brocade, Li brocade, Dai brocade, Hui brocade and so on. Among them, Zhuang brocade is also one of the representatives of the many ethnic brocade.

Guangxi Zhuang Autonomous Region is located in the south of China, between east longitude $104^{\circ}28' \sim 112^{\circ}04'$, north latitude $20^{\circ}54' \sim 26^{\circ}23'$, across the central Tropic of Cancer. It connects Guangdong Province in the east, Beibu Gulf in the south and Hainan Province across the sea, Yunnan Province in the west, Hunan Province in the northeast, Guizhou Province in the northwest, and the Socialist Republic of Vietnam in the southwest. The administrative area covers an area of 237,600 square kilometers, and covers an area of 40,000 square kilometers. The Zhuang nationality is the most populous ethnic minority in Guangxi and China, mainly living in Nanning, Liuzhou, Chongzuo, Baise, Hechi and Laibin. Among them, brocade city is the county-level administrative region with the highest proportion of Zhuang population, reaching 99.7%. At present, Zhuang brocade is mainly distributed in brocade city, Binyang, Xincheng and Longzhou and Daxin.

This study uses "social memory" to analyze what kind of social memory is produced in Zhuang people under different social backgrounds? Then, how was the Zhuang brocade remembered by the Zhuang people in the course of history?

Zhuang brocade is one of the most important handicrafts of the Zhuang people. It is a textile accompanied by Zhuang women in their daily work, and it is a living memory and cultural carrier in the history of the Zhuang people. With gorgeous colors, rich patterns, exquisite skills and a wide range of uses, Zhuang brocade has become the living carrier of "social memory", which contains many memory information of Zhuang people and others. However, as a folk art, Zhuang brocade is rarely recorded in the official historical documents, so the birth and early evolution process of Zhuang brocade have disappeared in the long river of history. Therefore, this paper analyzes and studies "social memory" from the aspects of writing, written symbol, oral memory and physical text.

There are not many relevant records, but the basic veins and characteristics of Zhuang brocade can be found from the records of historical documents. In the period of social change, the function and value of Zhuang brocade usually change, so the phased study is carried out according to the historical stages. First, the feudal society period is divided into two stages: one is the Song and Yuan dynasties, which is the formation and growth stage of Guangxi brocade. Such as Liao Mingjun and Lu Chun (2012) in the Guangxi embroidery culture recorded in Guangxi folk keep many

Zhuang brocade inventor legend, the inventor for women is given priority to, including milo, wang, fairy girl, mulberry and qiao ni, not only expressed the zhuang people yearning for love and a better life, but also reflects the zhuang women intelligent kind, industrious and capable image, and gives Zhuang brocade has symbolic significance of love. In addition to the legendary characters, there are also folk stories, such as "The Origin of Zhuang Brocade", "A Zhuang Brocade", "Harry Learn to weave Brocade", "Special Rooster", "Three Sisters Send Bird Clothes", etc. Among them, "The Origin of Zhuang Brocade" is widely spread in the Zhuang people:

Legend has it that in the Song Dynasty, there was a Zhuang woman named Dani Mei. One day, when she was thinking hard, she suddenly saw the light shining on the spider webs under the eaves, which inspired her. Since then, Dani sister has been in the traditional weaving technology, referring to the grain of spider webs, weaving a magnificent zhuang brocade. Around the women famous, have for her weaving strong brocade marveled, and learned to her the technology of weaving strong brocade. Since then, zhuang brocade has gradually become popular in the Zhuang area, and zhuang women have passed on this brocade technology from generation to generation.

Second, the Ming and Qing Dynasties were the formation and development stage of Zhuang Brocade; there is a record of Moran's invention of colorful Zhuang brocade:

"Xincheng County Annals" records, in the reign of Mor, Xincheng County brocade has been very popular. When Mormaan was in his 10s, he had learned and mastered brocade techniques from his parents. One day, when Moran went up the mountain to pick up mulberry leaves, he found the dew on the spider web in the morning light. So, Moman returned home to think hard, with colorful lines for latitude, primary color yarn for classics, finally invented the colorful zhuang brocade. Subsequently, Moman designed the lion rolling ball, phoenix wearing peony, double dragon play beads and other patterns of zhuang brocade. She knitted the color zhuang brocade is very popular, foreign merchants take the initiative to order. Moru's wife learned that Moran could weave a colorful brocade, and invited her to the yamen to teach technology. Moran is very generous, in addition to the yamen to teach technology, but also passed to other villagers. Since then, Xincheng zhuang brocade famous, the production scale of brocade has been rapidly expanded.

From the literature records to the legend stories, we can basically find that the "of white square grain " in the Song Dynasty is the beginning of Guangxi brocade, to the Ming Dynasty Xincheng brocade artist Mo an improved brocade technology, invented colorful brocade. It shows that Guangxi brocade experienced the initial single color and gradually developed to the multi-color process, which laid a solid foundation for the formation of zhuang brocade in later generations.

Second, the semi-colonial and semi-feudal period mainly includes the late qing dynasty and the republic of China, under the war and the impact of the capitalist market, Zhuang brocade development into the period of decline, people no longer make complex Zhuang brocade, began to use industrial textiles replace Zhuang brocade, for this issue of the zhuang brocade use from royal tribute to ordinary people, become the zhuang marriage custom important symbolic items, also become zhuang women essential "red".

Third, the socialist period, namely since 1949, is divided into two stages: one is the period from 1949-1978 for the socialist revolution and construction stage, and the second is the reform and open to the outside world stage from 1978-2023. In the historical process, the Zhuang people in the early stage of socialist construction and reform and open to the outside world after the process of modernization, the use of the Zhuang brocade pattern, the social environment, lifestyle and aesthetic concept change and significant adjustment, Zhuang brocade original old use adjustment, and in the new environment of purpose or innovation using the old model. Therefore, this study focuses on the process of transition from old usage mode to new mode. In this paper through the field survey Zhuang brocade main production area, such as brocade Jingxi, Binyang, Xincheng, Longzhou field investigation, especially with brocade Xinjin town for research focus, widely collected new brocade town Zhuang brocade users, producers and consumers, the existence of social memory information, through the study and analysis of Zhuang brocade artistic and cultural value and the deep meaning behind it.

In the evolution process of Zhuang brocade, it is influenced by the exquisite skills of Zhuang women in all dynasties and Zhuang culture, and Zhuang brocade has become a distinct symbol of Zhuang culture. Its production materials, weaving techniques and pattern patterns have been handed down from generation to generation among the Zhuang women, carrying and condensing the wisdom and aesthetics of the Zhuang women for more than one thousand years. In the use of color, Zhuang brocade uses the bright, high purity yellow, red, blue, green as the main color, supplemented by other colors, formed a bright contrast, gorgeous and dazzling visual effect. Zhuang people in making Zhuang brocade, often use subjective color collocation, such as "red with green, see good" "deep everyone love, shallow also not bad" color principle, pay attention to the use of contrast color, with contracted color show rich level, at the same time pay attention to the master tone, make Zhuang brocade color is bright and dazzling, and durable. In the Ming and Qing dynasties, the ancestors of the Zhuang people used local unique plants, such as madder, gardenia, turmeric, indigo, as stains for cotton thread or velvet. After the Republic of China, influenced by the influence of the cotton textile market, the Zhuang people in brocade Jingxi area began to use more ready-made dyed cotton thread or velvet to weave Zhuang brocade, and this tradition has continued to this day.

Zhuang brocade is very heavy in pattern decoration, with a wide range of themes, concise shape and abstract generalization. The composition adopts a balanced composition, that is, change in repetition and simplicity. Its unique shape, rich connotation and superb skills all reflect the wisdom and emotion of the Zhuang people. There are many kinds of Zhuang brocade patterns, with different classifications. This paper is based on the perspectives of "social memory" and "traditional invention", and the use and implication of Zhuang brocade patterns: it mainly includes traditional patterns and innovative patterns. The traditional geometric pattern includes diamond pattern, square pattern, circular grain, ten word pattern, sun pattern, water ripple, cord pattern, cloud flower pattern, plum pattern, hibiscus pattern, osmanthus pattern, octagonal pattern, kapok pattern, phoenix pattern, chicken pattern, crane pattern, unicorn pattern, tiger pattern, dragon pattern, deer pattern, cow pattern, fish pattern, fish pattern, butterfly pattern, butterfly pattern, butterfly pattern, etc. Innovative pattern flower basket pattern, bronze drum pattern, copper coin

pattern, embroidery pattern, feather pattern, frog man pattern, Liu Sanjie pattern, duet pattern of folk songs, rock painting pattern, bronze drum dance pattern, etc. The above patterns are not only derived from life and nature, but also deeply rooted in the totem worship and national psychology of the Zhuang nationality, reflecting the Zhuang people's yearning for and pursuit of a better life.

Zhuang brocade as a representative of the Zhuang culture symbol, its generation and development of the Zhuang people, groups and community, cleverly put some image of the nature, through, exaggerated deformation, bold induction and reasonable choice, the Zhuang history and culture, life form, customs into Zhuang brocade patterns, make Zhuang brocade pattern is rich national characteristics, and has strong expression, the formation of Zhuang characteristic graphic language, so "social memory" on the Zhuang brocade pattern. For example, the myths and legends of patterns and mliua, the myths and legends of bird patterns and bultuo, the myths and legends of animal and plant patterns, and the connotation of Zhuang brocade patterns are linked with these myths and legends. For example, pattern, bird pattern, feather man and ox pattern are closely related to ancestor worship, cloud thunder pattern symbolizes the worship of Thor, water ripple symbolizes the worship of the god of water, and octagonal pattern symbolizes the worship of the sun. These patterns reflect the Zhuang people's reverence for the gods, express people's hope for good weather, good grain and prosperous people, and express the Zhuang people's yearning and expectation for a better life.

After the implementation of reform and open to the outside world in 1978, China entered the process of modernization development, and its so-called "tradition" not only grew in the social process, but also died out in the social process. So what are the laws of "tradition" and "social process"? How to understand the so-called "tradition" in the long river of time? What innovations and suggestions are made in the protection of intangible cultural heritage?

Although after reform and open to the outside world in China, Zhuang brocade has entered the stage of innovation and development. On the basis of inheriting the traditional patterns, it has also added patterns reflecting the regional customs, time life and spiritual outlook as the themes, such as: copper encouragement, Huashan rock painting, Guilin landscape, ethnic unity, harmonious home, etc. However, under the impact of the market economy, the high cost and low output handmade Zhuang brocade products gradually lost the market and declined, and the large number of technical personnel made the Zhuang brocade skills on the verge of extinction. In 2006, after Zhuang brocade became a national intangible cultural heritage project, the government issued various policies to support the research and development and production of Zhuang brocade, and to reshape the tradition and explore the innovative development of Zhuang brocade.

The traditional patterns and innovative patterns record the historical memory, national memory and cultural memory of the Zhuang nationality. Through the rich materials, numerous silk threads, bright colors and abstract patterns, we can trace the "social memory" behind the unique aesthetic form of the Zhuang nationality. The patterns and patterns of Zhuang brocade play the role of beautifying and decorating, but the more important role is to play the role of national cultural symbols, bearing the inheritance of the national culture, living conditions and religious beliefs of the Zhuang people. Therefore, organically combine the "social memory" in the traditional

Zhuang brocade with the modern fashion aesthetic, give full play to the practical value and cultural significance of Zhuang brocade in the modern society, occupy different consumer markets, so as to drive the spread, development and inheritance of Zhuang brocade, and make this ancient Zhuang handicraft revitalize and inherit alive.

The reasons for choosing Guangxi Zhuang brocade as the study text in this study are as follows. First, I work in Baise University, Baise City, Guangxi Province, which is one of the important gathering places of the Zhuang people. brocadexi Zhuang Brocade Factory, as the first batch of national intangible cultural heritage projects, has retained perfect zhuang brocade weaving skills, brocadexi Xinbrocadeg Town and other villages to weave zhuang brocade, which facilitates field work research. Second, the lack of historical documents in the development process of Zhuang brocade makes it difficult for the study of Zhuang brocade. Through the analysis of the history, memory, inheritance and perfection in the "social memory" of Zhuang brocade, "traditional invention" is used to analyze and study how Zhuang Brocade is a "tradition" in modern society and become the most representative cultural symbol of the Zhuang people in Guangxi. Third, in the decades of research of Zhuang brocade, the value and significance of the inheritance of Zhuang brocade have not been deeply studied from the interdisciplinary perspective of "social memory" and "traditional invention". Four is to meet Guangxi art institute folk art expert professor wang rui, the Guangxi zhuang autonomous region museum Zhuang brocade research experts wei-feng wu, Zhuang brocade art national non genetic bearing Li Cunling, Chinese arts and crafts master Tan Xiangguang, Zhuang brocade collectors Feng Sen, Yang Zhuojian, and new brocadeg town of Zhuang brocade woven niang, etc., for subsequent research direction, collecting information and consulting experts to lay a solid foundation, so that in-depth study of Zhuang brocade new areas, for Zhuang brocade living inheritance and development of power, let more people know and love Zhuang brocade culture.

Through the collection and collation of relevant literature, by May 2023, there were 539 papers with "Zhuang brocade", including 66 core papers of Peking University, 27 CSSCI papers and 4 doctoral papers. There are more than 200 related monographs as the key words of textile, brocade and zhuang brocade. It can be seen that the current research of Zhuang brocade has two characteristics: first, the history, pattern of Zhuang brocade, art, craft, intangible cultural heritage, cultural industry, zhuang costume and folk customs; the second is less research on "social memory" and "traditional invention".

Some studies on the history of Zhuang brocade include: Zhou Qicheng, Zhao Feng, Bao Ming new General history of Chinese Textile (2017); Zhao Feng, brocade Lin's textile archaeology (2007); Zheng Chaoxiong's source of Zhuang aesthetic consciousness (1991); Fan Daozhi, Wan Fubin's brief History of Zhuang Brocade (2018); Wu Weifeng's textile industry in the history of Zhuang brocade (1995) on the rise and fall of Guangxi Zhuang brocade (1999), etc. Zhou Qicheng, Zhao Feng and others presented the development context of textile from the overall history of textile and archaeological relics of China. Zheng Chaoxiong, Wu Weifeng, Fan Daozhi and others analyzed and studied the historical context of Zhuang Brocade.

The studies on Zhuang brocade patterns include: the study of Lu Qiong (2017); Xu Xin, Lu Jie, Yang Xiaoming, from the interpretation of ——Guangxi

Zhuang brocade pattern (2014); Zhang brocade gmaio (2013); the geometric patterns of Wu Huimin (1986).

Research on Zhuang brocade technology are: Xu Xin's Zhuang traditional textile technology and its culture (2016); Wu Weifeng Guangxi Zhuang brocade technology (1990); Wu Weifeng, CAI's Zhuang Brocade (2018); Wu Yu, Wu Weifeng Zhuang traditional dyeing materials and Zhuang brocade dyeing technology (2018); Tan Liping Guangxi Zhuang brocade Brocade technical research (2012).

Related studies on brocade social memory include: Study on population history of Tujia brocade of Yang Honglin and Fan Zhuyuan (2019); Study on Tujia brocade Cultural Heritage of Ran Hongfang —— (2017); Symbol and memory of Sun Hailan and Jiao Yongqin- -Study on Brocade Culture of Li nationality (2012); Wang Wen's descendants of New Lankapu: Master of Tujia brocade and History of Inheritance population (2010).

Among the research on the non-genetic inheritance of Zhuang brocade are: Wu Weifeng's Zhuang brocade: Colorful wisdom crystallization (2022); Yan Xuemei's Research on high-quality Development of Intangible Cultural Heritage Industry —— Take Zhuang brocade Industry as an example (2021); Wu Dequn's Protection and Innovation: Research on the Creative Transformation of Zhuang Brocade from the perspective of Intangible Cultural Heritage (2021); Analysis on Jia Dongxia's Productive Protection of Intangible Cultural Heritage —— Taking zhuang brocade brocade as an example (2021); Analysis of Guangxi Binyang Zhuang brocade Cultural Inheritance from the perspective of LAN Ying and Fang Shaojuan (2019); Zhou Yahui's inheritance and reproduction: Research on Dong brocade in Hunan Channel (2018); Ran Hongfang's National symbol —— Study on Tujia Brocade Cultural Heritage (2017); Zhou Qin's China Cotton Industry Research Report (2015); —— Take the practice of Zhuang brocade as an example (2014).

The research on Zhuang Brocade culture and art include: Zhuang Brocade Culture of Jade Dynasty (1992); Ye Hongguang, Li Bin's brocade flower: Tujia brocade Culture (2018); Wang Yiping, Mo Wanyu's Guangxi Zhuang brocade and its cultural value and functional change —— Take Xincheng Zhuang brocade as an example (2015); Ma Hong's aesthetic art and inheritance of Zhuang brocade (2007). In addition, Zhuang brocade modern derivatives and innovative communication have been developed from daily necessities to the field of music, the public environment of architectural design and others. The above innovations will be analyzed in the follow-up research.

This study will adopt the method of qualitative research, use the two concepts of "social memory" and "traditional invention" to study Guangxi Zhuang brocade, and study the interaction between Zhuang brocade and Zhuang society since the Song Dynasty, so as to further solve the inheritance of Zhuang brocade in the modern society.

2. Purpose of the Research

2.1 To study the historical, social and cultural background of Guangxi Zhuang Brocade.

2.2 To study and analyze the "social memory" of Guangxi Zhuang Brocade before and after the reform and opening up.

2.3 To study and analyze the "traditional invention" of Guangxi Zhuang Brocade after the reform and opening up.

2.4 To study and analyse the social memory and traditional invention of Zhuang brocade in Guangxi through folk activities in the context of China's reform and opening up.

3. Research questions

3.1 How was the historical, cultural and social background of Guangxi Zhuang Brocade from the past to the present? How to determine the development stage of Zhuang brocade through literature sorting, and how to determine these time stages?

3.2 How was the text identity of Zhuang brocade exist and adapt before the reform and opening up? How does the social memory of Zhuang brocade play, symbol and meaning?

3.3 How was Guangxi Zhuang Brocade invented traditionally after the reform and opening up? How does it integrate into the Zhuang folk festival and become a commodity and art? How to show the artistic value of Zhuang brocade?

3.4 How to study and analyse the social memory and traditional invention of Zhuang brocade in Guangxi through folk activities in the context of China's reform and opening up?

4. Definition of Terms/ Concise/ More Compact

4.1 Zhuang brocade: In the Zhuang language, it is called "mbaw laiz fax" and literally translated as "the page of the grain of the sky", which represents a lofty and unique artistic status. Its unique production process is reflected in the primary color cotton yarn as the meridian, the color velvet as the latitude line, through the warp and latitude interweaving, woven colorful, complicated patterns. The magnificent colors and rich patterns displayed by the Zhuang brocade are not only the product of the deep integration of the Zhuang people with the Zhuang culture in the long history, but also the treasures of their unique national art. They not only reflect the deep worship of the Zhuang people for nature, but also contain their yearning and pursuit for a better life. Therefore, Zhuang brocade is in the research dimension of "social memory" and "traditional invention".

4.2 social memory: In the social economy, physical practice is an important link, and Zhuang brocade is one of them. It is an important practice for Zhuang brocade to interact with the Zhuang people through different forms. Weaving Zhuang brocade, using Zhuang brocade and wearing Zhuang brocade is an important practice of closely interacting with the bodies of the Zhuang people. It is also part of social memory, so "social memory" is an important key word used to describe the historical, social and cultural background of Zhuang brocade through interaction, writing, pictures and space, especially in the context before reform and open to the outside world.

4.3 traditional invention: It is usually a practice that has been controlled by open or privately accepted rules, has a ritual or symbolic characteristics, trying to instill certain values and norms of behavior through repetition, and necessarily implies continuity with the past. Historians care that in any time and region, they adjust the use of old things, occur in the new environment, and use the old model for new purposes. Therefore, this study uses the concept of "traditional invention" from the perspective of recall history to analyze and study the dimension of Zhuang brocade.

4.4 List of representative items of National Intangible Cultural Heritage: referred to as National Intangible Cultural Heritage, is a list of intangible cultural heritage that has been approved by the Ministry of Culture and Tourism and officially approved and published by The State Council of the People's Republic of China. So far, The State Council of the People's Republic of China has officially recognized and published five batches of representative items of national intangible cultural heritage in 2006,2008,2011,2014 and 2021. brocadegxi Zhuang brocade art was listed in the first batch of national intangible cultural heritage list in 2006.

4.5 Representative inheritors of National Intangible Cultural Heritage: referred to as national non-genetic inheritors, refers to the inheritors who assume the responsibility of inheriting representative projects in certain areas, and are recognized by the Ministry of Culture and Tourism. In 2007,2008,2009,2012 and 2018, the national cultural authorities named five groups of representative inheritors of national intangible cultural heritage projects, among which the inheritors of brocadegxi Zhuang brocade skills is Ms.Li Cunling.

4.6 Social process: it refers to the social interaction process in which an individual and biological person grows into a social person, obtains personality, and learns social and group ways. It specifically refers to the process in which individuals learn knowledge, skills and norms, obtain the qualifications of social members, and develop their own sociality. In the beginning of its existence to the peak period of development, it is accompanied by the social process of continuous innovation and development, in order to meet the needs of the development of The Times.

4.7 China reform and open to the outside world: From December 18 to 22,1978, held the third Plenary Session of the 11th Central Committee, began to implement the policy of internal reform and opening to the outside world, marking that China has entered a new period of reform and open to the outside world and socialist modernization. From proposing "reform", "opening-up" to "reform and open to the outside world", to "comprehensively deepening reform" and "forming a new pattern of comprehensive opening-up", it reflects the basic development context of China after the reform and open to the outside world.

4.8 commercialization: specifically refers to the things that do not originally belong to trading circulation and exchange through currency, but have been transformed or mutated into trading and currency equivalent exchange under the conditions of market economy. From self-production and self-use to market development, it is mainly influenced by the government guidance and consumers, prompting Zhuang brocade to constantly innovate in the process of commercialization to adapt to the new consumer demand and innovation.

4.9 Non-governmental activities: refers to the non-profit activities initiated and participated in by civil society organizations or individuals voluntarily, covering social networking, culture, entertainment, sports and public welfare activities. Among

them, the social organization activities represented by public welfare and charity, as well as the fields involving ethnic culture, art and sports, all belong to the category of folk activities. This paper focuses on folk activities as relatively stable cultural activities gradually accumulated and inherited from generation to generation by a nation or social group in the long-term production practice and social life, and from generation to generation, which can be simply summarized as popular folk customs or custom activities, especially represented by March 3rd of the Zhuang Nationality activities.

4.10 March 3rd of the Zhuang Nationality: As a traditional festival in Guangxi Zhuang Autonomous Region, it is also known as March 3rd in Guangxi. It is a unique traditional festival of the Zhuang nationality formed from the long-time accumulation and evolution of the Zhuang nationality and their ancestors under the specific historical conditions and living environment. Its customs are rich and colorful, including sacrifice to ancestors, choosing songs, grabbing fireworks, making five-color glutinous rice, throwing hydrangea, playing carrying poles, playing bronze drums and zhuang brocade display. In 2014, "March 3rd of the Zhuang Nationality" was officially listed in the fourth batch of representative items of national intangible cultural heritage, reflecting the recognition of its profound cultural heritage and unique value.

5. Scope of Research

5.1 Study concept

Two main concepts are used in this study: "social memory" and "traditional invention".

The concept of "social memory" was first used by French social psychologist Maurice Halbwachs, who believed that a person's memory is never specially customized by an individual, but originated from the process of collective communication, where individuals can only be recalled in a collective and social framework. As for the relationship between individual memory and collective memory, he said, "Individuals recall by placing themselves in the position of the group, but they can also be sure that the memory of the group is realized through the individual memory and embodies themselves in the individual memory" (Halbwachs, 2002.P: 39-40). In the late 20th century, social memory research continued to make new explorations, no longer satisfied with how the collective memory determines the memory, but discussing how the society as a whole remembers. Harald Welzer with Peter Burke research view, think social memory belongs to the category of recall social history, have "oral practice, conventional historical literature (such as memoirs, diary, etc.), drawing or pictures, collective memorial ceremony and geographical and social space", he defined social memory as: "a group of the sum of the social experience" (Welzer, 2007.P: 6). In addition, Sun Dezhong believes that "with the development of productivity, material and technical level, social communication status, cognitive thinking ability and the historical development of the presentation of cultural forms, social memory has roughly experienced several stages of historical types such as myths and legends, oral memory, characters and symbols" (Sun, 2006.P: 126-128). Guangxi Zhuang brocade It is one of the most important handicrafts of the Zhuang people, it is a textile accompanied by zhuang women in their daily work, and it is a living memory carrier in the historical process of the Zhuang nationality. Zhuang brocade as folk art, rarely recorded in the official history literature, and about the birth

of Zhuang brocade and the early evolution process has disappeared in history, but Guangxi Zhuang brocade itself has gorgeous color, rich patterns, exquisite skill, its material, color, patterns, art, and use, formed the "social memory" of live carrier, contains a lot of strong people and others memory information.

The "traditional invention" concept comes from the traditional invention work, Proposed by Eic Hobsbawm, He argues that " when the rapid transformation of society weakens or even destroys the social models that fit with the 'old' tradition, And produced a new social model which the old tradition can no longer adapt to; When these old traditions and their institutional carriers and communicators are no longer fully adaptable and flexible, Or when it has already been eliminated; in a word, When considerable and rapid changes occur on the demand side and on the supply side.traditional invention Will occur more frequently (Eric & Terence, 2020, P: 5)"

Therefore, the discussion of Guangxi Zhuang brocade mainly focuses on two core aspects, "social memory" and "traditional invention". On the one hand, traditional brocade is like a product of art; on the other hand, traditional brocade is also a cultural symbol. From the point of view of art, it is a highly aesthetic handicraft, composed of a variety of patterns and colors, used in important folk activities or life. From the perspective of a cultural symbol, it is a festival event, wedding, clothing,... is also a national intangible cultural heritage (Figure 1).

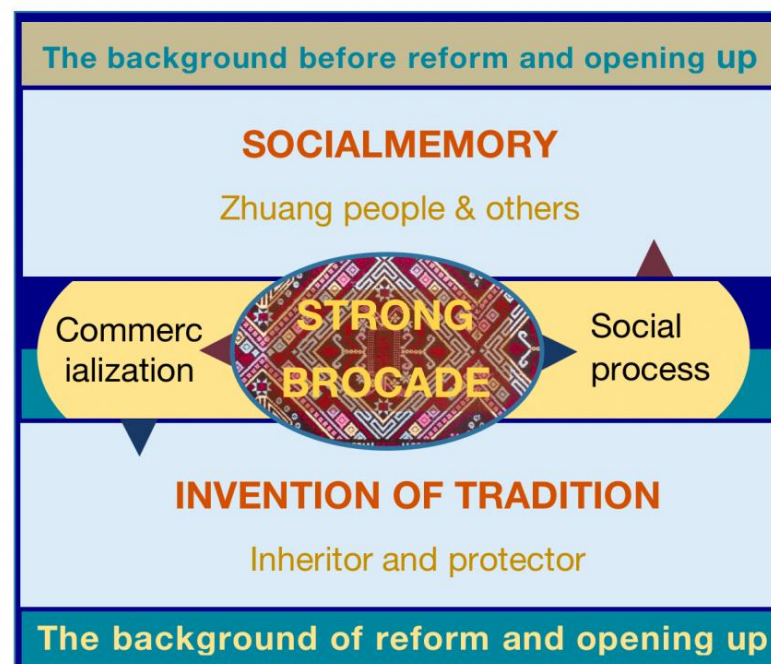


Figure 1 studies the conceptual framework
Source: Yaocheng Tian , Author: 2023

5.2 Research Conceptual Framework

In the framework of this study, the subjects are the Guangxi Zhuang brocade. Before the reform and open to the outside world in China, we can see the connection between the Zhuang brocade and the Zhuang people, which inherits and retains the culture and social memory of the Zhuang nationality. After reform and open to the outside world in China, the background of the social life of the Zhuang nationality has changed significantly. Guangxi Zhuang brocade has become the cultural symbol of the Zhuang nationality and an important folk art product of the Zhuang nationality,

and is closely related to the life, society, economy and culture of the Zhuang nationality.

6. Research Methodology

This study used a qualitative approach to Guangxi Zhuang brocade the past social memory and modern social relationships.

Qualitative study methods. Two main concepts were used in this study: "social memory" and "traditional invention". Information obtained through interviews, questionnaires and observations, Combing the development context and current situation of "social memory" and "traditional invention", Then analyze the "social memory" of the reform and open to the outside world before and after the reform and open to the outside world, And the "traditional invention" of Zhuang brocade after reform and open to the outside world. Finally, the "social memory" and "traditional invention" of zhuang brocade are studied and analyzed from the folk activities in Guangxi.

7.Data collection

7.1 Study population

(1) The Zhuang nationality native of brocadegxi

All the residents of Xinbrocadeg Town in brocadegxi are Zhuang people. It once had a brilliant history of Zhuang brocade. With the influence of reform and open to the outside world marketization, Zhuang brocade has disappeared rapidly in the villages of Xinbrocadeg Town. At present, the skills of Zhuang brocade are mainly preserved in the homes of brocadegxi Zhuang brocade Factory and a small number of farmers, but Zhuang brocade is still an important topic for the residents here. They have experienced everything about Zhuang brocade by themselves. We have interviewed Ms.Li Cunling, Ms.Nong Hongping, Ms.Huang Haizhen, Ms.Huang Xiaoyu, Ms.Huang Shiqi, Ms.Liang Lixia and other brocadegxi locals.

(2) Producer

The producer of brocadegxi Zhuang brocade Factory, represented by Ms.Li Cunling, the factory director. She is the inheritor of the national intangible cultural heritage Zhuang brocade skills. She is proficient in all the technological links of Zhuang brocade weaving, and actively participates in the production and innovation of Zhuang brocade. In addition, we also interviewed more than 10 employees in the factory, who play a pivotal role in the brocade production process. Most of the employees learn the Zhuang brocade skills by mouth or by apprentices. Their ancestors all have the Zhuang textile or Zhuang brocade skills and are committed to inheriting the Zhuang brocade culture.

(3) Designer

The design team of brocadegxi Zhuang brocade Factory is mainly composed of two types of talents: one is with exquisite brocade artists; the other is dedicated to folk artists. In the innovative design of Zhuang brocade pattern, the former usually personally participate in the whole process, they seek new changes in the inheritance, although not instantly meet the needs of social development, but the latter will combine the market demands, they only participate in the creative part, and then complete the actual weaving work, such innovative design performs well in the market feedback, and can quickly adapt to the market demand. At present, we have

interviewed Ms.Li Cun and Mr.Zeng Dan. In addition, we also interviewed Ms.Tan Xiangguang, Ms.Huang Aiqun, Ms.Fan Lihua and other zhuang brocade designers.

(4) Merchants

With the development of tourism in brocade city, some local residents have keenly captured the business opportunities and actively participated in the opening of Zhuang brocade handicraft shop, aiming to provide quality services for tourists, but also help to increase their own income.

(5) Consumers

At present, the consumer group of Zhuang brocade presents a certain instability, including local residents, tourists and collectors. At the same time, the number of consumers of zhuang-brocade-related derivative products continues to rise, and the scope of consumer groups is also expanding.

(6) Researchers / institute

They are the core force of the study of Zhuang brocade culture, deeply exploring and inheriting the essence of this culture. The team is composed of experts, professors, museum researchers, cultural scholars and experts from national institutions. They use scientific research methods to realize the activation and inheritance of Zhuang brocade culture. In the process of research, I have interviewed Mr.Wang Rui, president of Guangxi Calligraphy and Painting Academy, Mr.Wu Weifeng, Secretary of the Party Committee of Guangxi Zhuang Autonomous Region Museum, and Mr.Feng Sen, Secretary of the Party Committee of Guangxi Art School.

(7) Government officials

The government officials who formulated the development and protection policy of Zhuang brocade have interviewed Ms.Li Bihua, Vice President of brocade Federation of Literary and Art Circles; Mr.Mo Fuyao, Director of brocade City Mass Art Museum; Mr.Lu Shan, Director of brocade City Museum, etc. After in-depth interviews, the formulation of brocade Zhuang brocade development and protection policies has been actively participated in and supported by Ms.Li Bihua, Vice President of brocade Federation of Literary and Art Circles, Mr.Mo Fubao, director of brocade Mass Art Museum, Mr.Lu Shan, director of brocade Museum and other government officials. Together, they devote themselves to protecting and inheriting the unique cultural heritage of brocade Zhuang Brocade, and provide valuable opinions and suggestions for the formulation of scientific and reasonable policies.

(8) Collectors

The old zhuang brocade has a very high collection value. With the large range of zhuang brocade producers reduced, the longer the old zhuang brocade time, the more exquisite the pattern, the more superb the skills, and the higher the collection value. Among them, Mr.Feng Sen, the founder of "brocade Yuan", collects more than 3,000 pieces of Guangxi brocade from the Qing Dynasty, including more than 100 kinds.

7.2 Research tools and instruments

Interview, Ms.Li Cunling, director of brocadeqxi Zhuang brocade Factory (national non-genetic inheritor) and the weaver mother of Zhuang brocade Factory;
questionnaire
observe
data collection

Data were collected through the literature review. From research articles, monographs, magazines, newspapers, and fieldwork interviews, and so on.

7.3 Field work data collection

Interview: According to the on-site data, collect the memories and opinions of local residents, producers and tourists. It records the changes in its design, color, style and use over the years, and summarizes how it has formed a more modern way of influence to keep up with the development of society.

Questionnaire: mainly for local zhuang residents of brocadeqxi, all staff of brocadeqxi Zhuang Brocade Factory, tourists of brocadeqxi, researchers and designers of Zhuang brocade, etc.

Observation: participatory observation and non-participatory observation. It refers to interviews, questionnaires, observation focus group discussion

7.4 Documentary data collection

Collect literature data in Guangxi, CNKI, reference textbooks, libraries, electronic libraries, personal research and articles on Guangxi Zhuang brocade.

8. Scope of Research

8.1 Research area

brocadeqxi, Xincheng and Binyang in Guangxi are closely related to Zhuang brocade culture in the past to the present. At present, researchers have collected information in brocadeqxi area, and plan to expand information collection in Xincheng and Binyang areas in the later period. At present, the focus is on the production, distribution, use and culture of brocadeqxi Zhuang brocade Factory. In 2006, "Zhuang brocade technology" of brocadeqxi Zhuang Brocade Factory was first listed in the national intangible cultural heritage. In 2011, brocadeqxi Zhuang Brocade Factory won the title of national Intangible cultural Heritage productive Protection Demonstration Base again. In addition, The director of Li Cun Ling is the inheritor of national Zhuang brocade skills. brocadeqxi Zhuang brocade factory production of zhuang brocade hanging, murals, quilt surface, silk embroidered shawl and other products, with its unique technology, exquisite technology, solid texture, colorful characteristics, enjoy a high reputation in the domestic and foreign markets. The workers of Zhuang brocade Factory are basically local zhuang women in brocadeqxi. They all inherit the Zhuang brocade skills in the way of teaching by teachers and apprentices. Zhuang brocade Factory basically retains the traditional weaving skills of Zhuang brocade.

8.2 Time range

Study time period: They were divided into the following two periods:

(1) Before reform and open to the outside world (Song Dynasty-1978), we focused on the history of Zhuang brocade and the analysis of Zhuang brocade social memory.reform and open to the outside world After (1978-2023). In this period, the research focuses on the "social memory" change and "traditional invention" process under the transformation of social mode.

(2) My study began in March 2021 and ended in December 2023.

(3) Other boundaries / another one

After reform and open to the outside world in 1978, brocadeGxi Zhuang brocade Factory was under the influence of market, society, design, decoration, patterns and other aspects. Zhuang brocade has gradually changed from daily life items to an important traditional cultural symbol of zhuang residents' life.

9. Literature review

The researchers collected a series of literature on Guangxi Zhuang brocade, for the study of social memory and traditional invention in the context of reform and open to the outside world.

Zhuang brocade has existed and developed for several centuries. In the process of research topics and field investigation, I have consulted some relevant documents as follows:

9.1 About Zhuang brocade

Zhuang brocade literature records:

In the archaeological excavation in Guangxi, sewing tools were unearthed in the late Paleolithic period (1956), and the original pottery wheel (1974) unearthed in the Neolithic period showed that textile skills existed in Guangxi at the end of the primitive society. Qin and han dynasties pottery spinning wheel has been common in the tombs, such as your port luoyang han tomb unearthed burial goods "black orange back grain brocade" and wood slips "from zhi" recorded the burial goods including many textiles, han dynasty Guangxi textile industry has flourished, at the same time in the early western han dynasty Guangxi use brocade, physical proof (1988).

During the Tang Dynasty, Guangxi brocade had become a famous cotton fabric. The Six Songs of the Tang Dynasty and the Annals of Yuanhe Counties recorded that a variety of fabrics woven by the Zhuang people at that time had been listed as tribute by the feudal dynasty.

Song dynasty zhuang ancestors adjust measures to local conditions, using the local hemp, ge, banana, bamboo, ancient end rattan, hook awn wood, bay (cotton), Mr.pinnata must, silk fiber as raw material, produce dry cloth, tube cloth, beam, willow cloth, sweet ge, cloth, banana cloth, bamboo cloth, five color spot cloth, some of the cloth also as a tribute on the court. In 1178, Zhou Qufei, the book "Ling" recorded: " Yongzhou around the cave man, there are white, white square grain, wide wisp, like the line of the capital, and beautiful thick, sincere south of the clothing also."White refers to the early plain Guangxi brocade. The appearance of Guangxi brocade marks that "Zhuang brocade" has stepped on the stage of history.

Although Fei's book Shu brocade spectrum in the Yuan Dynasty is a record of Shu brocade, it records the "Guangxi brocade" in the Song Dynasty in very few content, which is also the first time that Guangxi brocade has been recorded by

official documents in history. Among them, there are four categories of brocade recorded in the transfer Academy: "shanggong brocade", "imperial brocade", and "Guangxi brocade", which is the first recorded "brocade" named after "Guangxi" in historical documents, and also the first record of "brocade" in textiles in Guangxi.

During the Ming and Qing Dynasties, Zhuang brocade became mature and prosperous. Zhuang brocade was no longer unique to officials and dignitaries. It returned to the families of the Zhuang people from the temple and became the daily necessities of the Zhuang people. During the reign of Hongzhi of the Ming Dynasty (1488-1505), the third local official Mo Lu proposed the "brocade ke system" in the initial training of the official motto; the wife of the tenth local official Mo Zongzhao during the Jiabrocadedeg period (1522-1566), mentioned that "not clothes, but diligent textile". As the local chieftain attaches great importance to the development of Zhuang brocade, brocade technology is more and more exquisite, its scale is getting bigger and bigger. In addition, it is recorded in the book *Sisor* by Wei Rui in the Ming Dynasty: " During the Wanli period, the young brocade with dragon and phoenix patterns has become a tribute."And the dragon and phoenix pattern pattern of the zhuang brocade is produced in Xincheng.

During the reign of Shunzhi in the early Qing Dynasty (1638- -1661), Mo Meng, the 12th chieftain, "presented Tunas" and selected eight earth brocade with exquisite patterns such as "dragon and phoenix playing beads" and "lion rolling ball" as tributes. In the 29th year of Qianlong (1764), the Liuzhou Prefecture Annals edited by Wang brocade recorded: " Zhuang brocade came from all prefectures and counties. Zhuang people love color, where the dress towel is, never take five color velvet miscellaneous to weave for flowers and birds, far view quite clever gorgeous."The Palace Museum in Beibrocadedeg collects several tribute pieces of Zhuang brocade during the reign of Emperor Qianlong in the Qing Dynasty, highlighting its historical value and cultural heritage. At the same time, Zhuang brocade also became an indispensable female red of zhuang women at that time.

In the Jiaqing period of the Qing Dynasty (1796-1820), Xincheng's brocade skills reached its peak. Mo Zhen (1772-1840) vividly described this grand occasion in "Xincheng Bamboo Branch Ci · October": " In October, the mountain city is brightly lit, and every family weaves brocade all night. At the beginning of the crow, the weaver stopped, and then the sound of pounding clothes and pound rice."This truly reflects the busy scene of brocade production in Xincheng. In the ninth year of Daoguang (1829), Yingxiuxiu and Tang Renzuan recorded in Daoguang Qingyuan Fu Annals: " Xincheng Tu County paid tribute to the court every year, up to 20 end, and with decorative silver 462 a money, which was presented to the court by the government through the salt law institution."" All states and counties have soil brocade output, especially in Yongding, Xincheng for delicate."

During the period of the Republic of China, Zhuang brocade mainly relied on the folk inheritance for free development. Since the founding of new China, zhuang brocade and its weaving skills have been highly valued and strongly supported by the state. Based on the cooperative background in the 1950s, the production mode of Zhuang brocade has gradually changed from the traditional family workshop to the factory production. At the same time, in brocadegxi, Xincheng and Binyang, with the support of the government, these enterprises have gradually developed into collective enterprises directly under the state-owned Second Light Bureau. After entering the

1980s, Zhuang brocade production ushered in a golden period of rapid development, the production efficiency was generally improved, and successfully entered a new stage of scale and industrialization. However, with the deepening of reform and open to the outside world and the rapid development of market economy in the 1990s, due to the high production cost of Zhuang brocade, it has gradually not adapted to the purchasing power of ordinary consumers. Therefore, in 1994, Xincheng Zhuang brocade factory had to face closure due to poor management.

Since the beginning of the 21st century, with the attention of leaders at all levels and all sectors of society, Zhuang brocade has begun to usher in the opportunity of innovative development. In 2003, Guangxi Institute of Arts and Crafts national brocade factory was established, and began to use electric motors to produce Zhuang brocade. In May 2006, Guangxi Zhuang brocade art was included in the first batch of national intangible cultural heritage list, marking a new stage in the development of Zhuang brocade and the "traditional invention" process. In May 2010, in the third batch of intangible cultural heritage projects, Guangxi Zhuang Autonomous Region increased the first batch of Xincheng Zhuang brocade techniques and Binyang brocade skills, and expanded the protection scope and support of Zhuang brocade techniques. In December 2018, the Longzhou Zhuang brocade art in Longzhou County was included in the seventh batch of representative items. In 2011, with the support of governments at all levels, the "Guangxi Embroidery Development Research Association" was established to establish a communication platform for embroidery artists. The introduction and implementation of the above policies have laid a solid foundation for the development and inheritance of Zhuang brocade. In addition, in 2007, Guangxi organized Zhuang brocade artists to jointly produce a large-scale work of Zhuang brocade, dedicated to the 10th anniversary of Hong Kong's return, setting the largest record in the world at that time. In 2010, the Zhuang brocade artists used the world's largest bamboo cage machine to create the Guangxi Zhuang brocade, which was presented by the government of the autonomous region for permanent collection.

The Study of Zhuang brocade History:

Zhuang brocade is a product gradually formed by the Zhuang people in the long-term production practice, which has accumulated historical deposits for many years. However, the academic circles have different opinions about the origin of Zhuang brocade. In the Brief History of the Zhuang Nationality, the Zhuang Brocade believed that it originated in the Song Dynasty (1980). Qin Guosheng and others wrote Zhuang, that it originated in the Han Dynasty (1984). Neither of these claims presents evidence and is more general.

Zheng Chaoxiong (1991) discussed the origin of Zhuang brocade in detail. He thought that Zhuang brocade originated in the Song Dynasty is based on the record of "Guangxi brocade" in Shu brocade Pu: " Song Dynasty, At the age of tribute, silk, The first year of Yuanfeng (1083), Duke Lu Ji, The brocade courtyard was built in the east of the government, To raise five hundred men to weave, To the official position... The brocade being woven, There are four different: shanggong brocade, official brocade, official brocade, Guangxi brocade " to speculate that Zhuang brocade originated in the Song Dynasty is not logical. He pointed out that, according to the records of the Shu brocade spectrum, Chengdu needs to pay a certain amount of brocade tribute to the imperial court every year, Among them, including the "Guangxi brocade", That's why

Lu set up the brocade courtyard, Convenor to the brocade. Therefore, "Guangxi brocade" should have existed before the establishment of Chengdu Brocade Institute.

Wu Weifeng (1995) discusses the hemp industry, cotton industry and silk industry development of Zhuang brocade raw material selection, dyeing technology and stitch important role, at the end of the article he talked about the origin of the Zhuang brocade, agree with Zheng Chaoliang view, on the basis of added the Zhuang brocade and shu brocade in weaving methods, think there is no Zhuang brocade developed from shu brocade, points out that this view ignores the basis in the history of the zhuang region textile technology.

Wu Weifeng (1999) reviewed the tortuous development course of Zhuang Brocade from the Song Dynasty to the 1990s, and believed that there were three reasons for the gradual decline of Zhuang brocade: first, Zhuang brocade was a tribute to the court in the Ming and Qing Dynasties, which was expensive, only used by princes and nobles, and was rarely used by ordinary people in their daily life. Second, because the cost of zhuang brocade is high, the technology lags behind, it is difficult to keep up with the trend of the market economy. Third, because zhuang brocade raw materials are precious, narrow use, difficult to popularize.

The book *Zhuang brocade*, co-authored by Wu Weifeng and CAI (2018), deeply analyzes the historical formation and development of Zhuang brocade, a traditional handicraft, and discusses its unique artistic characteristics and rich cultural connotation in detail. The book comprehensively and systematically describes the Zhuang brocade in the form of pictures and pictures, presenting a three-dimensional and vivid world for the readers. This move has played a positive role in promoting the inheritance and development of Zhuang brocade, and has a great significance that cannot be ignored. In addition, the book also emphasizes that in the process of protecting Zhuang brocade, it is necessary not only to inherit its exquisite production skills, but also to pay close attention to the development of the inheritors to ensure the sustainable inheritance of this precious cultural heritage.

Wu Weifeng (2022) extended the development of the factory, the decline of folk brocade, professional research on the new model of the company, and included the introduction of zhuang brocade skills of the national intangible cultural heritage project and the small biography of the inheritors, which enriched and improved the content of the historical development of Zhuang brocade after reform and open to the outside world.

In addition, Fan Daozhi and Wan Huibin (2018), based on the unearthed cultural relics and documents in a *Brief History of Zhuang Brocade*, The development experience of Zhuang brocade is summarized as the beginning period of the Han Dynasty, The mature period of the Tang, Song and Yuan dynasties, The heyday of the Ming and Qing Dynasties, In the late Qing Dynasty and the Republic of China, The founding of new China to the reform and open to the outside world is a tortuous period of development, Finally, under the background of "revitalization of traditional crafts", the revitalization and prospect of Zhuang Brocade, This article is based on the dynasties in the history of China, Briefly combed the evolution context of Zhuang brocade, It is one of the few achievements with the historical development of Zhuang brocade as the main research object.

The above research results trace the origin of Zhuang brocade, clarify the development process of Zhuang brocade, and study the historical evolution of Zhuang brocade by analyzing historical materials and deepening the production and life of the Zhuang people, which has certain organization and persuasion, and lays a solid foundation for the study of Zhuang brocade later.

Research on Zhuang brocade Technology:

Zhuang brocade is a traditional handicraft of the Zhuang nationality, and its production technology has also evolved. At present, Guangxi Zhuang brocade uses brocadexi brocade machine, Binyang brocade machine, Huanjiang brocade machine and modern computer control machine. The production of Zhuang brocade requires 15 processes, and the whole production process is composed of traditional processes such as pulling, combing, wearing brown and cutting panels. The original weaving of zhuang brocade relies on manual operation, with complex process and complicated process. Some modern links have been replaced with mechanized products, but the jacquard still retains the traditional artificial way. At present, the research achievements of zhuang brocade production technology mainly discuss the structure of brocade machine, zhuang brocade dyeing technology and jacquard technology. Wu Yu, Wu Weifeng (2018) also demonstrated from the unearthed cultural relics, historical relics and real life, that the traditional dyeing materials of the Zhuang nationality are mainly mineral colors and plant color, and analyzed the dyeing process of plant grass, yellow gardenia, mineral cinnabar and ochre in the zhuang brocade silk thread.

Shen Congwen (2017) said that the brocade of cultural relics, including articles on archaeological appreciation of brocade. He demonstrated the images and literature materials in a realistic way. Although it was a research result decades ago, it has important reference value for modern brocade. Xu Xin (2016) conducted a systematic, holistic and historical study on zhuang textile technology. She used professional chemical engineers analyzed the dyeing principle of bluegrass, detailed records the zhuang weaving and brocade steps and the working principle of bamboo cage machine, by comparing the textile of different ethnic machine, points out that the zhuang brocade machine and other ethnic textile differences, zhuang brocade machine has a complete frame, using two pages to all and interactive to lift, has distinct local characteristics. The academic achievements of the research on the production technology of zhuang brocade systematically analyzed the internal structure of the brocade machine, the dyeing and jacquard technology of zhuang brocade, presented the weaving process of zhuang brocade in detail, deepened people's understanding of zhuang brocade, and clarified the ideas for the later research in the field of zhuang brocade.

Wu Weifeng (1990) The brocade technique of Guangxi Zhuang nationality is divided into two parts. One is the comparison of Huanjiang brocade machine, Binyang bamboo cage machine, and the development trend of Zhuang brocade weaving technique of brocadexi brocade machine. In addition, Wu Weifeng (2014) in the zhuang brocade art works, from the history of Zhuang brocade, technology, design, development and protection of five aspects such as Zhuang brocade more comprehensive specific ethnic writing Zhuang brocade, book from hemp, cotton, silk and other crop industry production development, detailed combed the history of

Zhuang brocade, points out that in the song dynasty or shu brocade courtyard, Guangxi brocade already exists, but is clearly Zhuang brocade in the song dynasty, the Ming and qing dynasties Zhuang brocade weaving technique is quite mature. Tan Liping Guangxi Zhuang brocade brocade technology research (2012) of brocadeg west and binyang Zhuang brocade brocade comparative study, first of all the Zhuang brocade technical parameters, second to the structure of Zhuang brocade loom, again on the characteristics of retaining Zhuang brocade core technology, combined with modern textile technology into Zhuang brocade weaving, finally study and discuss how Zhuang brocade product innovation. The above studies have summarized and sorted out the process development context of Zhuang brocade.

Research on brocade Culture and Art:

For a long time, the cultural value of Zhuang brocade has been deeply explored. Zhuang brocade is an important part of Zhuang culture. It is one of the most important representative symbols of Zhuang culture. It is also an important carrier reflecting the customs, religious beliefs and aesthetic concepts of the Zhuang people, with rich cultural connotation.

Studies from the semiology perspective, Fan Xiujuan and Wang brocadegbrocadeg (2021) From the perspective of national cultural symbols, It is believed that Zhuang brocade is in the urban cultural and ecological space, Both the traditional "inheritance" and the traditional "invention", In the context of a modern and global urban society, Zhuang brocade contains the ecological aesthetic symbols with multiple meanings, Characterizing the ethnic identity, Also said that the spiritual home, Thus, to promote the national spirit, Must construct a national cultural space of identity, Relying on the symbols of traditional culture to place the national spirit and strengthen the national consciousness, From the national cultural symbol —— traditional invention —— cultural ecological space, This paper discusses the significance and value of Zhuang brocade culture in the construction of national spirit and cultural identity. Ning Qingli (2010), studied from the perspective of cultural symbols, Zhuang brocade art is the most representative cultural representation form in the zhuang ethnic art in the pre-industrial society, Bearing the rich national cultural connotation and national spirit, It is believed that Zhuang brocade art carries the " best ethnic cultural tradition of Guangxi Zhuang to the world, Let more people know more about Guangxi, Understanding the reality of the Zhuang nationality ", It also points out that it is the local cultural elites and political elites who use traditional culture to actively express their ethnic groups, Strengthening the collective memory and history of the community, Highlighting the unique significance of the Zhuang nation in history, It also discusses the significance of Zhuang brocade culture from the level of memory. Jade Age (1992) believes that the zhuang brocade pattern is an emotional symbol, which gathers the culture of the Zhuang nation, contains certain cultural connotation, symbolizes people's pursuit of a better life, and reflects some positive things. At the same time, he also pointed out that the choice of Zhuang brocade colors is restricted by the cultural and psychological qualities of the Zhuang customs, religious beliefs, historical traditions and aesthetic concepts, and these cultural characteristics reflect the unique national style of Zhuang brocade.

Under the perspective of cultural ecology, LaoHuan (2021) from the perspective of cultural ecological binyang Zhuang brocade culture need protection and inheritance, must strengthen the Zhuang brocade art propaganda, make more people familiar with Zhuang brocade art and culture, then Zhuang brocade culture inheritance and modern social culture, realize the development of Zhuang brocade culture modernization needs. Blue ying and Fang ShaoJuan (2019) from the perspective of cultural ecological analysis of the origin and development of Zhuang brocade, the legend and origin of Zhuang brocade, in Zhuang brocade production and development, zhuang ancestors totem worship and folk belief way of thinking and state of mind, not only reflected in the origin of Zhuang brocade legend, also reflected in the Zhuang brocade design and pattern form the characteristics of legend, think Zhuang brocade design and color and design highlights the farming culture in Guangxi, has important historical and cultural value. NongWenJun (2017) from the cultural ecological environment horizon, discusses zhuang brocade culture in the generation, inheritance and development of the ecological environment, also counterproductive ecological environment, in the ecological culture environment brocadedegXi Zhuang brocade from people's daily necessities developed into a commodity, has evolved into a cultural symbol, have important relationship with the political environment at that time. From the perspective of ecological aesthetics, Wei Sijie proposed that "Na culture" has influenced the historical development and the evolution of cultural customs of the Zhuang people for thousands of years, shaped the life form and behavior mode closely related to the Zhuang people and the land, and also gave birth to the ethnic artworks with the aesthetic form of "Na culture". As an ancient Zhuang arts and crafts, Zhuang brocade shows the harmonious relationship between the Zhuang people in the communication with nature, and enriches and continues the "that culture" of the Zhuang nationality with the aesthetic form with great ecological aesthetic meaning.

Cultural change under the perspective of research, such as Zhang Yuhua (2016) from the perspective of cultural ecological analysis of Zhuang brocade concrete performance in cultural changes, such as the change of pattern, the change of raw materials, production technology and the change of function, in-depth analysis of Zhuang brocade culture changes influenced by productivity, education and science and technology and the influence of communication way of life. It points out new directions and ideas for Zhuang brocade in his practical research. Another example is Wang Yiping and Mo Wanyu (2015), on the basis of tracing the origin and development of Zhuang brocade, analyzed the tools, techniques, patterns and colors of Zhuang brocade, put forward that Zhuang brocade has the cultural value of "incorporating feelings in things" and rich and diversified social values, and pointed out the reasons for the weakening and change of the value of Zhuang brocade.

From the perspective of art, Tang Qikui (2022) proposed that the folk art rooted in the traditional rural society is shaped and constructed again in the new cultural context. Guangxi Zhuang brocade Art plays an important function in daily life, and reflects their life experience and aesthetic consciousness. The symbol of Zhuang brocade art to create a public cultural ecological landscape is of great value to the construction of national and individual cultural identity. Member handsome (2018) through the collection of Guangxi ethnic minority brocade, with fine arts

perspective key analysis and explore the Zhuang brocade pattern composition, color collocation, reveal Zhuang brocade art cultural connotation, put forward Zhuang brocade in meet the basic needs of life at the same time, more the practical function of material and spiritual needs, become a "living fossil" of national cultural memory. Ma Hong (2007) cut into Zhuang brocade from the aesthetic perspective, believing that the unique aesthetic appreciation of Zhuang brocade art is mainly reflected in its exquisite weaving technology, simple and lively pattern art, rich and colorful cultural implication, indispensable decoration technology and so on. It is of positive practical significance to excavate and organize zhuang brocade and protect this folk cultural heritage on the verge of loss.

And scholars from a different perspective of Zhuang brocade culture research, such as Liao Mingjun and lu chun (2012) in Guangxi the legend of embroidery characters, customs and life, which included about Zhuang brocade "mulberry and qiao ni" "mila" and "wang" legend, brocade to national classification, and briefly analyzes the living environment of all nationalities, production conditions, national character, life habits, art, hobbies, and the characteristics of brocade style and formation. Yu yu (1989) to study the style of Zhuang brocade, think Zhuang brocade is zhuang women in labor or leisure, spontaneously formed folk weaving, by the Zhuang brocade weft line flower technique, using coarse surface, form thick texture, pattern effect stereo effect, and the han region are gentle smooth style is completely different. In addition, no official brocade production organization was set up in history, so Zhuang brocade was not bound by the will of the ruling class and bureaucrats, and formed its own unique national art style under the long-term natural growth of the folk. Under the background of Huang Feiyue (2018) Belt and Road, he conducts in-depth research on the inheritance and development of Zhuang brocade culture, and believes that "Belt and Road" is the external publicity, market development and policy opportunities of the development of Zhuang brocade. At the same time, it also faces many challenges, and also puts forward new ideas for the inheritance and development of Zhuang brocade. JiXiao ning and Wang Chong (2022) under the vision of brigade fusion, points out that Zhuang brocade social function changes, its development inheritance faces many problems, with culture to the tourism industry, the Zhuang brocade combined with tourism industry, under the support of the government, with the Internet, new media, new technology, promote the spread of Zhuang brocade culture development and inheritance, and driving the development of local tourism economy.

Since reform and open to the outside world Zhuang brocade is no longer the textile itself, as a typical symbol of zhuang culture, Zhuang brocade meaning also many changes, such as the Baise government funded opera "Zhuang brocade", huang of the traditional Chinese painting creation Zhuang brocade, Nanning and brocadegxi Zhuang brocade road, Zhuang brocade has from the original brocade, gradually through literary and artistic creation to show the zhuang culture. In addition, many modern derivatives and innovative communication have developed from daily necessities to the field of music, the public environment of architectural design and others. Therefore, the Zhuang brocade carries the rich cultural connotation of the Zhuang nationality, and is of great significance to the inheritance and development of the Zhuang nationality culture.

Study on brocade pattern:

Zhuang brocade mostly uses yellow, red, blue and green with high brightness and high saturation as the basic colors, while the other one uses more supplementary color, forming a sharp contrast and strong visual effect. The color of Zhuang brocade is usually dyed by the local unique plant dyeing. The ancestors of the Zhuang people also learned to use plants for dyeing in the long-term practice, such as madder for red, gardenia and turmeric for yellow, and indigo for blue. Zhuang brocade in the very heavy decorative patterns, its patterns are changeable and rich in local characteristics. The patterns are mainly geometric patterns and dragon and phoenix, flowers, birds and animals, etc., among which the geometric patterns have square (diamond) patterns, hui pattern, "swastika" pattern, cloud thunder pattern, water ripple, octagonal grain, concentric circles, etc. Legend of the theme of the story has double dragon play beads, double phoenix sunrise, lion rolling ball, butterfly love flower, fish jump, dragon gate, mandarin duck playing in the water and so on. Most of these patterns come from life and nature, from the totem worship of the Zhuang people, and from the Zhuang people's yearning for a better life. Following the historical tradition, they skillfully summarize or exaggerate some forms in nature, and boldly summarize and choose the depicted objects, so that the graphics are full of characteristics and strong expression, forming a graphic language with distinctive characteristics of the Zhuang nationality. Most of these traditional patterns contain the historical and cultural memories of the Zhuang people, the thunder pattern symbolizes the worship of thunder, the water ripple symbolizes the worship of water god, and the anise pattern symbolizes the worship of the sun... in the primitive wilderness, the ancestors believed that everything in nature was a god, thus forming the primitive religion and belief. Fear of the gods, people hope for good weather, good harvest, prosperity and other good wishes. The phoenix is the totem of the Zhuang people, is the auspicious thing, expressed the nation's yearning and expectation for a better life. The academic circles have made great achievements on the zhuang brocade decorative pattern.

Feng Sen (2019) is the famous Zhuang brocade collector, his collection of more than 3000 Zhuang brocade art and culture research, tracing the Zhuang brocade patterns, and Zhuang brocade treasures appreciation, and Zhuang brocade collection, his research with knowledge popularization, is also the first from the perspective of collection and appreciation of Zhuang brocade cultural and artistic value. Zhuang brocade (2018) by Wu Weifeng and CAI summarizes the different historical backgrounds of ethnic minorities in Guangxi, and analyzes the history of Zhuang brocade by combining the legends, historical documents and archaeological data. The current distribution of zhuang brocade is investigated, and the color and pattern of zhuang brocade are studied, and put forward the direction for the inheritance and development of zhuang brocade. Among them, the inheritance lineage of brocade gxi brocade is sorted out and the problems existing in the development are put forward. Lu Qiong (2017) systematically discusses the origin, classification, distribution of zhuang brocade patterns and the evolution of zhuang brocade in the form of doctoral thesis. In modern Zhuang brocade part papers after the founding of new China in 50-70 Zhuang brocade prosperity and silence, after reform and open to the outside world short prosperity, industrial tightening period of market economy regulation, in the 90s after the development of the 21st century, grain in grain "shape" and "meaning" study Zhuang brocade shape and meaning, and combined with zhuang pronunciation

annotation pattern name. Study the weaving skill and decorative function of zhuang brocade, and propose that the decorative decoration of zhuang brocade has aesthetic function, ethnic identity function, ethical norms and educational function. Finally, it puts forward the living inheritance and digital protection of zhuang brocade skills, and the development and innovation of zhuang brocade decoration.

Cai Hong (2017) combined the cultural connotation of Guangxi Zhuang brocade, Yao brocade, Miao brocade and Dong brocade patterns to explore the cultural connotation of Guangxi ethnic minorities and reveals the connection with their social, historical, economic life, cultural and traditional aesthetic taste and religious belief. Xu Xin, Lu Jie, Yang Xiaoming (2014) studied the collection of Guangxi Museum of Nationalities. They analyzed the patterns of Zhuang brocade from the perspective of composition, and the patterns are divided into geometric patterns, flower patterns, animal patterns, Chinese character patterns and innovative patterns. It is believed that the pattern of Zhuang brocade is constantly evolving under the influence of zhuang totem, belief and absorption of Han culture. Compared with other scholars in the field of Zhuang brocade, their innovation lies in increasing the discussion of the influence of Han culture on the generation and development of Zhuang brocade pattern. Zhang brocade/miao (2013) from the perspective of national culture zhuang brocade pattern connotation, the zhuang brocade pattern geometry and concrete pattern two types, and the source of the pattern and the natural environment, points out that the zhuang people through the nature after highly summarized, created product, is the national belief, national culture folk customs and reproduction worship intertwined artistic image. WuHuimin (1986), Zhuang brocade geometric pattern origin, first on the basis of Guangxi art college teachers and students national team and Guangxi museum collection of Zhuang brocade, Zhuang brocade geometric pattern is divided into three categories, and with the Guangxi unearthed geometric pottery, tonggu geometric pattern analysis, geometric grain is from the ancient southern minority production and life, for Zhuang brocade pattern origin research put forward new arguments. Shao Yu (1982) compiled Guangxi brocade, which introduced Guangxi Zhuang brocade, Yao brocade, Miao brocade and Dong brocade in Japanese, and promoted Guangxi brocade with both pictures and pictures.

In addition, some scholars have studied the pattern types of Zhuang brocade. For example, Huang Qing(2021) studied the origin of the octagonal star pattern in zhuang brocade, extended the depth and breadth of the zhuang brocade pattern from the theory of the sun, supernova, and the loom axis parts, and analyzed the reasons for the prosperity of the octagonal star pattern in Guangxi. Fan Miaomiao (2014) conducted an in-depth study on the phoenix patterns in Zhuang brocade. Through the analysis of 2162 zhuang brocade physical patterns in the collection of Guangxi Museum of Nationalities, he found that there were 52 animal patterns, mainly phoenix, dragon, lion, tiger, chicken, unicorn, butterfly, fish and so on. Among them, 15 cases involved phoenix patterns, accounting for 28.84% of the physical animal patterns of zhuang brocade in Guangxi Museum of Nationalities, and 0.0069% of the total zhuang brocade in the museum. The zhuang brocade physical pattern has a great contrast in proportion. The author chooses the phoenix pattern in the zhuang brocade for special research, which enriches the research objects and expands the depth and breadth of the study of the zhuang brocade pattern.

In addition to the ontology research, there are many cross-disciplinary and interdisciplinary educational, application-oriented and innovative studies, which will not be listed here. Taking Zhuang brocade pattern as a symbol expands other space and practical environment, which plays an important role in shaping and popularizing Zhuang brocade cultural symbols, and also provides a new perspective for the inheritance and development of Zhuang brocade.

Research on the non-genetic protection of brocade: With the development of economic globalization, under the impact of market economy and global commercialization, the lifestyle of Zhuang people has undergone a great change. In the process of rapid transformation, Zhuang brocade has gradually lost its original living environment, and its inheritance and development are facing a serious crisis. Since 2006, when brocade of Zhuang brocade technique was listed as one of the first batch of national intangible cultural heritage projects, Zhuang brocade has been transformed from folk handicrafts into an intangible culture supported by the government, and its symbolic and value changes have also been endowed with new significance. Subsequently, the regional government also promoted the protection and inheritance of Zhuang intangible cultural heritage, in the third batch of provincial intangible cultural heritage projects in Guangxi in 2010, the Zhuang brocade art was expanded to the Xincheng Zhuang brocade art and Binyang brocade art expanded its protection scope; in 2018, the brocade of Longzhou County was included in the seventh batch of provincial intangible cultural heritage representative items, so the main distribution in Guangxi has been listed as the intangible cultural heritage project for protection. The field of intangible cultural heritage protection of Zhuang brocade has also become a popular research direction, and its research results are quite abundant, and the monographs on Zhuang brocade research also appear.

Since 2006, the domestic research on intangible protection, including Wang Yuan (2021) from the perspective of cultural identity, aims at the inheritance of intangible cultural heritage development problem to establish a theoretical interpretation framework, the system interpretation of the development of intangible cultural heritage survival inherent mechanism, especially the typical cases of China's intangible cultural heritage, to explore the path characteristics, and thus to China's future intangible cultural heritage protection strategy. Zhou Yahui (2018) takes the Dong brocade in Hunan Channel as the object, and gives a comprehensive description of the geographical environment, origin and function, weaving materials and techniques, artistic aesthetics and humanistic expression of the Dong brocade. Combined with the current inheritance and production and operation status of Dong brocade, the inheritance and reproduction mechanism of Dong brocade techniques is explained in detail, which explores a new space for the non-genetic inheritance and protection of Dong brocade, and has reference significance for the protection of other intangible cultural heritage of Dong brocade. Ran Hongfang (2017) studied the national symbol "Xilankapu" from a new perspective, adopted the theory of "semiotics" to study the Tujia brocade, deconstructed its cultural elements, and explored the cultural connotation. After a large number of field investigations, the problems and difficulties faced by Tujia brocade in the intangible cultural heritage are summarized, and the protection and inheritance of the "authenticity" of Tujia brocade are pointed out. The above research has important reference and reference value for the research results of Zhuang brocade intangible cultural heritage protection.

The overall research of Zhuang brocade mainly focuses on industrialization development, creative transformation, living inheritance, productive protection, development protection and so on. Such as industrialization development research, xue-mei yan (2021) summarizes the Zhuang brocade industry development achieved initial results, and analyzes the problems facing the Zhuang brocade industry development, and put forward should increase the productive protection of intangible cultural heritage and support of specific measures, innovation Zhuang brocade enterprise management mode, design, product design and brand training, optimize the marketing mode, stimulate market vitality, strengthen talent training and relying on Zhuang brocade culture construction theme museum, Zhuang brocade general education. For example, in creative transformation research, Wu Dequn (2021) proposed the innovation of Zhuang brocade from the perspective of creative transformation, and mentioned the integration of Zhuang brocade into modern industry and modern life, through symbolic transformation, the elements of Zhuang brocade into modern design, the second is as a significance representation, participate in major activities and ceremonies, constructive direction for the intangible cultural heritage protection. Such as living inheritance research, yu-hua zhang (2020) with Zhuang brocade pattern for cases, think Zhuang brocade pattern contains the zhuang people's national memory and national spirit, put forward Zhuang brocade in living inheritance to subject cultural consciousness, build folk craft inheritance experiential practice teaching, the Zhuang brocade pattern into the innovation practice of productive products. Such as productive protection, xiao-chun liu and cold Jianbo (2016) from the national intangible cultural heritage project selected nine cases, including brocadeXi Zhuang brocade as a case analysis, think Zhuang brocade productive protection produced certain results, points out in the Zhuang brocade industrialization and productive protection, productive protection as the ultimate goal to "protection", "production" just means, and industrialization for the purpose of maximizing economic interests, in the "intangible" productive protection reflection for Zhuang brocade living inheritance and development provides the train of thought.

In addition, Xu Ganli (2014) recognized that in the productive protection of Zhuang brocade, it should reflect on the insurmountable problems of consumers, inheritors and products themselves. She proposed that the government should play a supporting and regulatory role in the productive protection, enhance the artistic aesthetic value of Zhuang brocade, and maintain the positioning of high quality and high price. Ding Jicai (2013) discusses the development of national cultural industry and the protection of minority intangible cultural heritage, and the differentiation path of cultural industry development in ethnic minority areas determines the development of ethnic cultural industry. The cultural characteristics of intangible cultural heritage determine that cultural industry is an important path for the protection of handicrafts. For example, in the development protection research, He Jianwu, Gao Yanling (2010) research on the development protection of intangible cultural heritage in ethnic areas — Take Guangxi Zhuang brocade as an example. Qinghai Ethnic Studies. It is also analyzed about the role of the government in the protection process. Teng ZhiPeng, Liu Kaie, Chen Yilin (2012) from the Zhuang brocade existing scale, inheritance analysis of spontaneous inheritance is impossible, put forward the government in the protection of Zhuang brocade intangible to the leading role position, from physical preservation, skill transmission and inheritance protection, and national spirit, the

Zhuang brocade stereoscopic protection inheritance work. Guo Heng (2012) explained from the perspective of cultural soft power that the government to the problems in the protection of Zhuang brocade, and put forward the government's analysis in the industrialization. Another Qiu Li (2018) from Guangxi intangible cultural heritage resources evaluation and creative platform construction of Zhuang brocade historical value, cultural value, spiritual value, aesthetic value and education value analysis, and put forward the construction of creative development platform, although no clear these guided by the government, but to plan as a whole the construction of creative platform should be guided by the government.

Another Zhuang brocade production area, such as Wenshan Zhuang brocade into zhuang clothing protection and inheritance, marshi beauty (2022) in Yunnan Wenshan Zhuang brocade as the research object, by using in Wenshan zhuang Zhuang brocade, Wenshan Zhuang brocade culture and artistic characteristics and living space, Wenshan Zhuang brocade protection and inheritance countermeasures are put forward. Enrich research beyond Guangxi Zhuang brocade. For example, Lu Chunyan (2021) studies the skills of more Danzhuang brocade in Silian Village, to enrich the existing region of Guangxi brocade, in order to better promote the inheritance and innovation needs of the traditional skills of ethnic minorities, enable the traditional skills of ethnic minorities to continue to develop, and enhance people's enthusiasm to pay attention to and protect the non-cultural heritage that will be lost. For example, Li Ping (2014), based on the perspective of the brocade gxi Zhuang brocade technique, proposed the development and research of the aesthetic value of Baise City, analyzed the ox totem, bronze drum totem and snake totem of the brocade gxi Zhuang, and discussed the expression of the aesthetic consciousness of the Zhuang totem. The main idea of the above research is to put forward improvement suggestions for the existing problems on the basis of analyzing the current situation of the protection and inheritance of Zhuang brocade.

Zhuang brocade is an important part of Zhuang culture and one of the important representatives of zhuang cultural symbols. Since reform and open to the outside world, Zhuang brocade has been impacted by modernization and marketization. From daily necessities to intangible cultural heritage, Zhuang brocade is still in a precarious state, and it still needs to conduct deeper research on it. At present, Zhuang brocade mainly studies historical research, art, aesthetics, art, cultural research and intangible cultural heritage protection, but pays too much attention to the research between Zhuang brocade and society. In summary, the research achievements are mainly domestic research achievements, but there are few research achievements on Zhuang brocade abroad, so there are only a few related discussions on Zhuang brocade from the perspective of social memory and traditional invention. In addition, most of the current research results are synteny studies, which stay on the description of the surface phenomenon of zhuang brocade, and lack of historical research on the development process of zhuang brocade.

9.2 About the Zhuang nationality

The Zhuang nationality is the most populous ethnic minority in China, and the Guangxi Zhuang Autonomous Region is the most concentrated living place of the Zhuang nationality. In addition, Wenshan Zhuang and Miao Autonomous Prefecture in Yunnan Province, Lianshan Zhuang and Yao Autonomous County in Guangdong Province, Congjiang County in Guizhou Province, and Jianghua Yao Autonomous

County in Hunan Province. Guangxi now has a population of 15,721,956 Zhuang people, mainly in Liuzhou, Laibin, Hechi, Nanning, Baise, Chongzuo and other areas. After 1949, after in-depth investigation and ethnic identification, the people's government in Guangxi, Guangdong, Yunnan and other places called "cloth zhuang", "cloth tu" cloth non "" "cloth Dai" "cloth" "BuLong" "" cloth "" cloth "" cloth "cloth" cloth "" cloth liao "" "", thus has a unified name. Later, in 1965, according to the initiative of Premier Zhou Enlai of the "servant", the "servant" was changed to "Zhuang" and "Zhuang"

After the founding of the People's Republic of China, studies on the history, social changes and history and culture of the Zhuang nationality began to increase. For example, the History and Status of the Zhuang nationality in Guangxi, written by Huang Zangsu (1958), elaborated the name and source of the Zhuang nationality. In the historical overview, it analyzes the policies of the rulers of the Zhuang nationality in the Tang, Song, Yuan, Ming and Qing dynasties, and mentions the development of textile in Guangxi in the Song Dynasty, and proposes the artistic development of Zhuang brocade in the Qing Dynasty. In addition, the social, political, economic and cultural characteristics of the Zhuang society before and after the founding of the new China are analyzed.

This paper systematically introduces the origin of the Zhuang nationality, and sorts out the development of the social economy and cultural life of the Zhuang nationality in different social periods according to the historical context, studies the history and patterns of the Zhuang brocade in the culture and art part, and summarizes the development and innovative patterns and products of the Zhuang brocade from the late Qing Dynasty to the liberation period. Huang Xianfan, Huang Zengqing, Zhang Yimin (1988) The general history of the Zhuang nationality, on the basis of the brief history of the Zhuang nationality in 1958, with rich and substantial historical materials as evidence, demonstrated the origin of the Zhuang nationality, comprehensively introduced the political, economic and cultural development of the Zhuang nationality in various periods, is the first general history of the Zhuang nationality. The paper discusses the history of zhuang brocade, sorts out the patterns of zhuang brocade, analyzes the three compositions of zhuang brocade patterns, and points out that there is a close origin between zhuang brocade pattern and pottery pattern and bronze drum pattern. From the perspective of aesthetic consciousness, Zheng Chaoxiong (1990) elaborated the aesthetic consciousness and the development of the ancient society of the Zhuang nationality, and also analyzed the social attributes of cultural and artistic aesthetics in different periods. Among them, the origin of zhuang brocade art was demonstrated in depth, pointing out that the production of "Guangxi brocade" was early on before the establishment of Chengdu Brocade Academy, and made in-depth research on the origin, history, skills and art of Guangxi brocade from literature records, textile materials and unearthed cultural relics. Next Wu Dequn (2017) from the perspective of cultural change, the social transformation of zhuang folk culture change, after the transformation of zhuang social status and characteristics, analyze the zhuang folk culture change power, change process, the trend of intangible cultural heritage protection under the framework of zhuang folk culture protection practice, and points out that the dilemma and countermeasures. Liang Tingyu (2021) Study on the history and culture of the Zhuang. The book is mainly divided into eight parts: ethnic footprint, Zhuang culture, Zhuang language

and writing, bronze drum culture, poetry ruins, Zhuang literature, Zhuang art, and folk religion, covering the main aspects of the study of the history and culture of the Zhuang. Specifically, it includes the historical footprint of the Zhuang nationality, the material and spiritual culture of the Zhuang nationality, the Zhuang language, the bronze culture of the Zhuang nationality, the origin and development of the song ruins, the original folk religion of the Zhuang nationality, the overview of the traditional art of the Zhuang nationality, the development course and prospect of the Zhuang literature.

9.3 On the policy

state level:

Publication of the Intangible Cultural Heritage of the People's Republic of China in 2011; the Implementation of the Development of Chinese Culture in 2017; the General Office of the CPC Central Committee and the State Council in August 2022; Notice of the Ministry of Culture and Tourism in 2023.

Local level:

The Regulations of Guangxi Zhuang Autonomous Region was adopted in 2006; The General Office of Guangxi Zhuang Autonomous Region, Industry and Information Commission and Finance Department of Guangxi Province in 2022.

In the 20th century 50, with the support of the local government, brocadegxi, Xincheng and Binyang Zhuang brocade factories were established, and developed into state-owned collective enterprises. In the 1980s, it entered rapid development, the production efficiency was generally good, and Zhuang brocade also entered the large-scale production stage. With the implementation of reform and open to the outside world and the development of marketization in the 1990s, Zhuang brocade production has not adapted to the purchasing power of ordinary consumers due to the high cost of production, among which Xincheng Zhuang brocade closed down due to poor management.

In the 21st century, Zhuang Brocade began to innovate and develop under the attention of leaders at all levels and people from all walks of life. In 2003, Guangxi Institute of Arts and Crafts was established and began to use electric motors to produce Zhuang brocade. In May 2006, brocadegxi Zhuang brocade art was included in the first batch of national intangible cultural heritage list, marking the development and traditional invention into a new stage. In 2011, with the support of governments at all levels, the "Guangxi Embroidery Development Research Association" was established to establish an communication platform for embroidery artists. In May 2010, the third batch of intangible cultural heritage projects in Guangxi Zhuang Autonomous Region expanded the first batch of provincial Zhuang brocade skills to Xincheng Zhuang brocade skills and Binyang brocade skills.

The introduction and formulation of the above policies lays a solid foundation for the development and inheritance of Zhuang brocade culture.

9.4 On the concepts

social memory :

Morris Habwar believes that " the so-called social memory is a thing shared, inherited and constructed by people in a group or modern society, whether it is material or immaterial, and becomes the iconic element of a group due to people's will or the baptism of The Times (Maurice Halbwachs, 2002)."

For Paul Connerton to clarify how social memory is transmitted, he proposed three different forms of memory, which can be summarized as: personal memory, cognitive memory, and social habit memory (Connerton, 2000).

Harald Welzer with Peter Burke's research view, think social memory belongs to the category of recall social history, have "oral practice, conventional historical literature (such as memoirs, diary, etc.), drawing or film pictures, collective memorial ceremony and geographical and social space", he defined social memory as: "the sum of social experience" (Welzer, 2007).

Sun Dezhong believes that memory is by no means a sensory behavior that only belongs to the individual psychological level, including social memory, collective memory or historical memory. "Society has different ways of self-replication and self-preservation from individuals, that is, social memory is different from individual memory in terms of nature, characteristics and function" (Sun Dezhong, 2003).

traditional invention: Hobbs Baum (Hobbs Baum, 2020) through six case study, discusses the process of invention, respectively, the Scottish national clothing, Wales, the royal ceremony change, the British Indian celebration etiquette change, African imitation of the British middle class lifestyle, and 1870-1914 Britain, France, Germany, national festival and mass culture changes. These historical processes of formalized and ritualized symbols are like the "signs and signs" of social change, which can be seen into the historical phenomena and hidden changes of society, nation and culture through the process of studying their "invention".

9.5 Related studies on other brocade materials

Zhou Qicheng, Zhao Feng, Bao Ming new (2017) China textile, is the first comprehensive discusses the original manual production to the contemporary power machine production of textile industry development history, the main content is divided into six: original manual textile period (neolithic), manual machine textile, the early development (Sui and Tang dynasties), manual machine textile development (Five dynasties to Ming and Qing dynasties), power machine textile introduction and growth (1840-1949), power machine textile development (1950-2010). Time from ancient times to 2010, the content covers science and technology, economy, culture, art and foreign exchanges, materials including fiber, yarn, fabric and clothing.

Zhao Feng, Brocade Lin (2007) textile archaeology, in the order, detailed the archaeological discovery in China in nearly one year of textile, textile tools, to reflect the historical textile process characteristics and technical level of the relatively in-depth analysis, and comprehensively introduces the research status of the ancient textile, for the future research provides rich reference materials.

Yang Honglin, Fan Zu (2019), interviewed more than 140 inheritors of Tujia brocade. First, the events recorded the personal experience of the inheritors, including the life experience and the experience of the brocade, they saw and heard the historical stories, myths and legends, the industry and the inheritors, which fill the modern historical documents of Tujia brocade and provide the reference value for the development of Tujia brocade.

Road Qiong (2017) to Guangxi Zhuang brocade craftsmen Tan Xiangguang as the main line, from the craft of the cultural environment, learning experience and skill inheritance, brocade process and process form are analyzed, through Zhuang brocade appreciation and interview record rich craftsmen research content, this work is one of

11. Benefits of Research

11.1 This study focuses on sorting and collecting the historical, social, ecological and cultural background of Guangxi Zhuang brocade, with reform and open to the outside world as the historical context and development of Zhuang brocade from Song Dynasty to 1978 and 1978 to 2023, and obtaining systematic data on the historical research of Guangxi Zhuang brocade.

11.2 This study focuses on song Dynasty-1978 and analyzes Guangxi Zhuang brocade social memory in the historical process of Zhuang ethnic group. From 1978 to 2023, it focused on field survey through the information collection of different groups to obtain the significance of it in the background of political, economic and cultural changes after reform and open to the outside world, so as to obtain the interpretation of Guangxi Zhuang brocade on the level of social memory dimension.

11.3 Study and analyze how Guangxi Zhuang brocade adapted to the new social model in the traditional invention process after reform and open to the outside world, and how it was transformed from daily necessities into an important cultural symbol of zhuang nationality, so as to obtain the explanation of Guangxi Zhuang brocade on the level of traditional invention dimension.

11.4 Through the analysis of "social memory" and "traditional invention" of Zhuang brocade in folk activities in Guangxi, reasonable conclusions and suggestions are put forward for the industrialization development, intangible cultural heritage protection and live inheritance of Zhuang brocade.



CHAPTER II

Guangxi Zhuang brocade Historical and artistic value

This chapter answers to the first research goal. The first research objective is to study the historical, social and cultural background of Guangxi Zhuang Brocade. On the important development period of zhuang brocade. The important development period of Zhuang brocade is segmented. This chapter is divided into three parts. The first part is the origin environment and production process of Guangxi Zhuang brocade; the second part is the history and development of Guangxi Zhuang brocade; the third part is the cultural and artistic analysis of Guangxi Zhuang brocade. This chapter lays the foundation for the analysis and research of Chapter 3 and Chapter 4.

Part I: Guangxi Zhuang brocade Production area environment, and the production process

This section analyzes the origin environment and production process of Guangxi Zhuang brocade. It is divided into three parts, the first is the environment of Guangxi Zhuang brocade origin; the second is the distribution of Guangxi Zhuang brocade origin; the third is the history of Guangxi textile and the production process of Zhuang brocade.

1.1 Guangxi Zhuang brocade Environment of origin

(1) The natural environment of the Guangxi Zhuang brocade origin

Guangxi Zhuang Autonomous Region is located in the south of China, north latitude $20^{\circ}54' \sim 26^{\circ}23'$, east longitude $104^{\circ}29' \sim 112^{\circ}04'$, across the central line of Cancer. Its unique geographical location, rich and diverse natural resources, superior climate conditions, rich biological resources. The northern half of Guangxi belongs to subtropical climate, the southern half belongs to subtropical climate and a small part belongs to tropical climate. The average annual temperature is between $16^{\circ}\text{C} - 23^{\circ}\text{C}$, the annual rainfall is between 1000 m- -2800 mm, and the average annual average sunshine hours is 1213-2135.2 hours. The overall climate is warm, full abundant rain and light. In summer, there is long sunshine time, high temperature, more precipitation, short sunshine time and dry and warm weather in winter (Figure 2).

The terrain of Guangxi is high in the northwest and low in the southeast, leaning from northwest to southeast. Surrounded by mountains, the central and south hilly flat, basin shape, known as the "Guangxi Basin". Guangxi has many rivers and rich water resources. The total water resources in Guangxi are about 237.73 billion cubic meters. The rivers within the territory belong to four major river systems, including Pearl River system, Yangtze River system, southern Guangxi system flowing into the sea and Baidu River system, among which the Pearl River system is the main system.

At the same time, Guangxi region is famous for its rich biological resources and diverse vegetation types. From north to south, there are three vegetation belts: central subtropical evergreen broad-leaved forest belt, southern subtropical evergreen monsoon rain forest belt, and northern tropical seasonal forest belt. There are more than 6,000 species of plants distributed. Zhuang ancestors in constant production practice, explore found suitable for natural textile material plant resources, such as ramie, bark, ge, banana, hemp, kapok, etc., these findings not only reveals the wisdom and creativity of the zhuang people, more thanks to the natural advantage of Guangxi

natural environment, for the textile industry in Guangxi and Zhuang brocade form provides a solid material basis and rich raw materials.

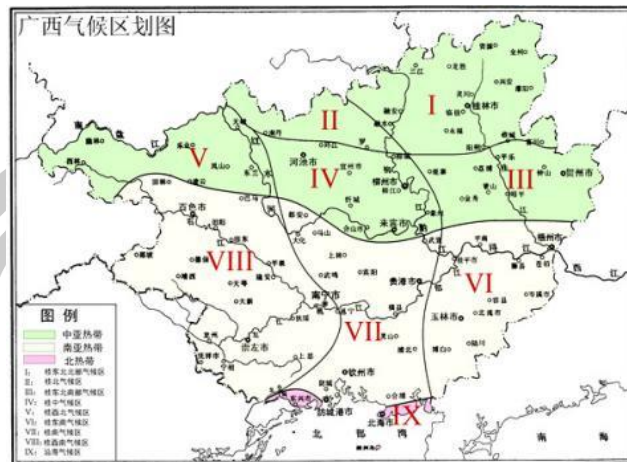


Figure 2 Climate Distribution map of Guangxi

Source: The Department of Ecology and Environment of Guangxi Zhuang Autonomous Region 17/January/2024

(2) Guangxi Zhuang brocade cultural environment of Guangxi Zhuang brocade origin

The Zhuang nationality is the most populous ethnic minority in China. Since ancient times, the Zhuang nationality and its ancestors have mainly concentrated in the Guangxi Zhuang Autonomous Region. The Zhuang area is full of rivers, fertile land, warm climate, which is one of the ancient human activities. In the original days of the Youjiang River Valley where the Zhuang people live together, many Paleolithic sites left by ancient human activities 600,000 or 700,000 years ago have been found, including many cultural relics. In the late Paleolithic period, more than 50,000 to 10,000 years ago, 13 human fossils and more than 100 cultural sites and relics have been found in the vast areas of central, southern and western Guangxi. For example, "Liujiang people", "Qilin Mountain people", "Bailian Cave people", "Jiutou Mountain people", "Du Le people", "Gan predecessors", "Baoji Mountain people", "Lipu people", "South Guangxi" Lingshan people, "West Guangxi" dry flood people, "Jiolengshan people", "Longlin people", "Dingding Cave people" and so on. In 221 BC, after The First Emperor of Qin unified the six states, there were xi'ou, Luoyue and Li Liao, which were mainly Baiyue ethnic groups in Guangxi, and gradually evolved into the Zhuang nationality in the Tang and Song dynasties.

Zhuang is smart wisdom, in the long process of the history, created a rich and colorful, unique national culture system, such as including unique totem culture, deep faith culture, "that" culture, long rice culture, solemn tonggu culture, gorgeous huashan culture, moving folk culture and exquisite brocade culture, these cultural achievements not only reflects the zhuang ancestors outstanding and immortal artistic creativity, more become its immortal cultural heritage. The ancestors of the Zhuang people also created a large number of myths, legends, folk stories and proverbs, which together constitute a rich and colorful treasure house of folk literature. For example, the long poem of Buluotuo created on the basis of Buluotuo mythology is an ancient and magnificent epic of the creation of the Zhuang people, vividly depicting the face

of the prehistoric Zhuang society. It describes the formation of the heaven and earth, the sun and the moon, the origin of human beings, the origin of various livestock and crops, and the life and production of ancient people, and warmly praises the great creation achievements of the first ancestor of the Zhuang nationality. Zhuang totem worship has distinct characteristics, believing that the totem object of worship is the personified god, and it is related to itself. Common totems include flower totem, bird totem, dragon and snake totem, frog totem, cow totem and dog totem. In a variety of divine beliefs, there are sun worship, thunder king worship, tree god worship, water god worship, fire god worship and land worship. These beliefs have profoundly influenced the daily living habits and artistic creation of the Zhuang people. Driven by the "Na" culture and the "rice-farming culture", the textile industry of the Zhuang nationality is very developed. During the Tang and Song dynasties, brocade techniques took root and sprouted in the life of the Zhuang people. In the Ming Dynasty, brocade went deep into the life of the Zhuang family, thus producing an artistic pearl with distinctive characteristics of the Zhuang nationality.

1.2 The ality distribution of Guangxi Zhuang brocade

Zhuang brocade, as one of the most magnificent and brilliant cultural creations of the Zhuang people, has a history of thousands of years. Zhuang brocade, Yun brocade, Shu brocade and Song brocade are among the four most famous brocade in China. Guangxi is rich in textile raw materials and has a long and special history, giving birth to a prosperous Zhuang culture. As an important representative of Zhuang culture, Zhuang brocade Guangxi Zhuang brocade is mainly distributed in brocadexi City, Binyang County, Xincheng County, Huanjiang County, Longzhou County, Daxin County, Long'an County, Hengzhou County, Nanning City and other (city) counties. In addition, in Yunnan Wenshan, Guangdong Qingyuan, Guizhou, Hunan and other places there are a few zhuang brocade distribution. At present, brocadexi, Xincheng, Binyang, Longzhou and other places are still in the production of zhuang brocade.

(1) brocadexi brocade Zhuang brocade

brocadexi city is located in the southwest border of China, under the Guangxi Zhuang Autonomous Region, Baise city administered by the county-level city. In 2014, the total population was 659,700, among which the permanent resident population was 519,500. The Zhuang population accounted for 99.4% of the total population, which is a typical zhuang population settlement in China. According to the historical materials and cultural data phenomena, brocadexi Zhuang Brocade originated in the Han Dynasty, formed in the Tang and Song Dynasties, and generally prevailed in the Ming and Qing Dynasties. In the Ming Dynasty, it was listed as a precious court tribute. By the late Qing Dynasty and the early Republic of China, it was in the decline stage.

brocadexi Zhuang brocade factory is located in brocadexi City. Founded in 1956 to form the embroidery society, and in 1960, it was renamed Zhuang Brocade Factory, engaged in zhuang brocade production and recruitment training. In 1976, the national brocade produced by brocadexi Zhuang Brocade Factory won the first place in the autonomous region. In 1985, Zhuang brocade Factory was designated as the national production of ethnic minority supplies designated enterprises. In 1987, the products produced by Zhuang brocade Factory were awarded the national Light industry minority products award. In 1989, Zhuang brocade series products were

awarded the quality award of Guangxi ethnic minority products. The products of Zhuang brocade factory have participated in the national and regional ethnic handicraft exhibitions for many times, and the products are exported to Hong Kong, Macao, Singapore, Japan, the United States, Canada and other countries and regions.

For many years, brocadexi Zhuang brocade Factory has been inheriting and carrying forward the essence of the excellent traditional handicraft technology of zhuang folk. In 2006, the brocadexi Zhuang brocade technique was included in the first batch of national intangible cultural heritage protection list. In 2011, brocadexi County Zhuang brocade Factory became a demonstration base for intangible cultural heritage production protection. In 2014, it was named as "Demonstration Base of Cultural Industry of Guangxi Autonomous Region" by Guangxi Department of Culture. At present, the main production of "brocadexuan brand" hydrangea and zhuang brocade hanging, murals, quilt surface, silk embroidered shawl and other products, with its unique technology, exquisite technology, solid texture, gorgeous color characteristics, enjoy a high reputation in the domestic and foreign markets."brocadexuan brand" hydrangea and zhuang brocade hanging bag, wall hanging and other products have repeatedly won the Ministry of Industry, the autonomous region of light industry quality products title. In the fifth International Asia-Pacific Expo in 1995, it won the gold and silver awards respectively. During the 40th anniversary of the founding of Guangxi Zhuang Autonomous Region in 1998, these products were designated as gifts for the celebration, and were highly appreciated and welcomed by guests at home and abroad (Figure 3).



Figure 3 Group photo with the director of brocadexi Zhuang brocade Factory

Source: Yaocheng Tian brocadexi Zhuang brocade Factory Field survey

2/October/2023

(2) Xincheng Zhuang brocade

Xincheng Zhuang brocade was first produced in the Song Dynasty, Xincheng County is one of the earliest counties to produce Zhuang brocade, is also one of the origins of Guangxi Zhuang brocade, has a history of more than 1,000 years. In the reign of the reign of Hongzhi in the Ming Dynasty (1488-1505), Mo Lu proposed the "brocade ke system" in the reign of the Jiabrocadeg Dynasty (1522-1566), the wife of Mo Zongzhao, the tenth local official, mentioned "no clothing, but diligent textile". As the local chieftain attaches great importance to the development of Zhuang

brocade, brocade technology is more and more exquisite, its scale is getting bigger and bigger. According to the records of Wei Rui in the Ming Dynasty in Sisr, "During the Wanli period, zhuang brocade with dragon and phoenix patterns has become tribute." And the dragon and phoenix pattern pattern of zhuang brocade, produced in Xincheng. Daoguang eight years of the "Qingyuan Fu Annals" (Qingyuan Fu in now Yizhou City) records: "Xincheng Tu County year for soil brocade four colors, as long as 20 end, decoration silver 462 a money, by the government solution salt method transferred." The twelfth chieftain Mo Meng (word Huairen) offer Tunas ", selected 8" dragon and phoenix play beads ", "lion rolling ball " and other patterns are very exquisite earth brocade as tribute. To the Qing Jiaqing years (1796-1820), Xincheng brocade reached its peak period. Mo Zhen in the "Xincheng Bamboo branch word" so described the scene at that time: "October mountain city lights are bright, every family brocade to the three more. After the chicken sang, he listened to the sound of anvil. In the Annals of Qingyuan Prefecture in the Qianlong period of the Qing Dynasty, it wrote: "There are soil brocade everywhere, and Yongding and Xincheng are exquisite." In the Palace Museum in Beibrocadedg, there are zhuang brocade from Xincheng, Guangxi.

At the beginning of the founding of new China, in order to ensure the inheritance of excellent ethnic products of ethnic minorities, China set up ethnic brocade factories in Xincheng, Binyang and brocadegxi counties. In the 1960s and 1970s, Xining Street, Dongan Street, Chengguan Town, Xincheng County, echoed with the sound of "ji ji". In 1986, the British Oxford Charity organization went to Xincheng for many times to investigate the production status of Zhuang brocade, and allocated more than 500,000 yuan to support the transformation of the equipment of Zhuang brocade factory and rural folk brocade point. After the equipment improvement, the annual output of Xincheng Zhuang brocade Factory was as high as 250,000 pieces. In 1989, Meng Rujun, then the director of Zhuang brocade Factory, was sent to Japan to teach the skills of Zhuang brocade, which was warmly welcomed by the Japanese people.

In the 1990s, with the rapid development of all walks of life, all kinds of textiles emerge in an endless stream, Zhuang brocade factory production of the surface, hanging bag, screen and other products are relatively single, high cost, the market gradually shrinking. In 1994, Xincheng Zhuang brocade factory stopped production. After 1996, Xincheng Zhuang brocade factory fell into economic difficulties, especially after the closure of Zhuang brocade factory in 1999, Xincheng Zhuang brocade weaving industry returned to the family workshop production mode. According to statistics, in 2013, Xincheng County only Meng Rujun and other 4 masters zhuang brocade craft inheritors are still weaving zhuang brocade. In May 2010, in the third batch of intangible cultural heritage projects, the first batch of the Zhuang brocade skills expanded the addition of Xincheng Zhuang brocade skills, so Xincheng Zhuang brocade skills has become a provincial intangible cultural heritage protection project.

(3) Binyang Zhuang brocade

Binyang Zhuang brocade is the treasure of Zhuang folk crafts and the bright pearl of the excellent cultural heritage of Guangxi Zhuang region. In the 1940s, Ms. Liang Shuying, the outstanding representative of Binyang brocade skills, went to Xincheng County for further study, which made a qualitative leap. After the founding

of new China, under the care of the party and the government, Binyang Zhuang brocade ushered in unprecedented opportunities for development. In 1956, Guangxi Binyang National brocade Factory came into being and became the designated production enterprise of ethnic products and one of the scientific research and production bases of brocade technology in China (Figure 4). Since the 1960s, Binyang Zhuang brocade has been across the ocean, sold to the United States, Japan, Canada, Italy, Kuwait and Southeast Asia and other countries and regions. In 1991, in the fourth National Traditional Ethnic Minority Sports Meeting, the zhuang brocade produced by Binyang Ethnic Brocade Factory became the designated product. In 1994, at the World Women's Congress held in Beibrocadeg, the zhuang brocade bags produced by the Binyang National brocade Factory became the special file bags for the delegates. In 1998, on the 40th anniversary of the founding of Guangxi Zhuang Autonomous Region, Binyang Zhuang brocade was awarded the designated product, since then, famous in China.

Binyang brocade technique strictly inherits the traditional zhuang brocade ancient weaving instruments, weaving techniques, weaving materials and pattern style. Compared with other brocade instruments, the biggest difference and feature of zhuang brocade loom is undoubtedly the big bamboo cage hanging on the loom, so zhuang brocade loom is also vividly known as "bamboo cage machine". In 2010, Binyang brocade art was listed in the third batch of autonomous region-level intangible cultural heritage list in Guangxi.



Figure 4 Binyang County National brocade Factory

Source: Yaocheng Tian field Photography 2/September/2023

(4) Longzhou Zhuang brocade

Longzhou Zhuang brocade is located in Beauty Village, brocadelong Town, Longzhou County, Chongzuo City, Guangxi Province, also known as Banchi Tun. It is a village with zhuang nationality as the main ethnic group. There are more than 200 families in the whole village, and the cash crops are mainly rice and sugarcane (Luo & Xu, 2020, P: 31). The zhuang brocade of "beauty village" has not only become the supplies and decorations in the daily life of the villagers, but also the weaving of zhuang brocade is the indispensable "female red" for the women of "beauty village". Zhuang brocade has become an indispensable thing in the dowry of "beauty village"

girls, which is the embodiment of the beauty of "show and benefit" of the beautiful village girls. In 2018, Banchitun, Shuangmeng Village, Brocadelong Town, the county, was rated as one of the top ten "intangible Cultural Heritage + poverty alleviation" employment workshops. On December 20 of the same year, the Brocadelong Zhuang Brocade Art in Longzhou County was included in the seventh batch of autonomous region level intangible cultural heritage representative items.

In order to better build the tourism brand of Brocadelong "Beauty Village" and inherit the cultural treasure of Zhuang Brocade, through the mode of "museum + enterprise + cooperative + farmers + market", under the leadership of Guangxi Weaving and Embroidery Development Research Association and Guangxi Zhuang Brocade Shanhe Culture Development Co., Ltd., embroidery women have not only achieved the goal of "getting rich with brocade at home", and effectively protect the Zhuang brocade skills, make the Zhuang brocade skills to be protected and inherited, realize the "productive protection" and "promotion inheritance" of traditional handicrafts, formed a "movable Zhuang brocade museum", thus driving the development of the cultural tourism industry. Make the value of Brocadelong Zhuang Brocade this intangible cultural heritage project.

1.3 The History of Guangxi textile and the production process of Zhuang brocade

(1) The history of Guangxi textile

The earliest textile tool found in Guangxi is a bone needle unearthed from the first phase of Zengpi Rock in Guilin (about 12000-11000 years ago) (Institute of Archaeology of Chinese Academy of Social Sciences, 2003, P: 89), which indicates that the ancestors of the Zhuang nationality have begun to make lines. In addition, stone spinning wheels and pottery spinning wheels were found in Neolithic sites around Guangxi (Huang, 1988, P: 87), indicating that the ancestors of the Zhuang nationality have mastered the spinning skills, and that the ancestors have mastered the spinning skills, and the original textile industry has begun to rise.

Historical records and archaeological data prove that the users of hemp fiber in Guangxi were first used by the ancestors of the Zhuang people. In Guangxi, the main settlement of the Zhuang people, the earliest hemp fabrics were found in the tomb of No.17, Matou Township, Wuming County (Huang, 1988, P: 14-22). The earliest type of hemp fabrics is the plain hemp fabrics unearthed from Han Tomb No.1 in Luobowan, Guizhou County, Guangxi Province. Its raw materials are hemp and ramie, and hemp seeds are also unearthed (Museum of Guangxi Zhuang Autonomous Region, 1988, P: 87). The earliest record of the ancestors of the Three Kingdoms. "Five-colored spot cloth with (like) silk cloth, ancient shellfish wood. This wood is ripe like goose cui, there are cores such as pearl Xun, fine silk cotton. People will use it, then out of its core, but not spinning performance, any small axis phase traction, no cut off. To spot cloth, then dye the five colors, thought cloth, weak and thick, vellus hair." Kapok trees are still very common in today's Guangxi region, and were clearly recorded in the Eastern Han Dynasty. According to the Annals of Foreign Objects by Yang Fu of the Eastern Han Dynasty, "The kapok tree is tall, in fact it is like a wine glass, and the thin skin is like silk cotton, breaking one can count two. Guangzhou, Rinan, Jiaocheng, Hepu all have it." It can be seen that the earliest cotton cloth in the Zhuang area should be made of tree cotton. During the Tang and Song dynasties, the GUI cloth "white like snow" produced in Guangxi was very famous at that time and was

very popular in the Central Plains market. Bamboo cloth was relatively famous in Guangxi during the Song Dynasty, and was still used in many areas until the Qing Dynasty. Rich fiber textile materials provide raw materials for the generation of Guangxi Zhuang brocade, and the long-honored textile skills provide technical support for the production of zhuang brocade (Table 1).

Table 1

Time	textile materials	textile	textile tools
Late Upper	,		Crude bone needle
Neolithic-Late Original Society	Ramie, ge, bamboo		Ceramic spinning wheel
Spring and Autumn Period and Warring States Period	Boehmeria nivea	flax	Pottery spinning wheels generally appear
during Qin and Han dynasty	Ramie, silk, kudzu	Plain coarse linen cloth, plain fine linen cloth, plain silk, plain yarn, brocade, ge cloth, cave cloth The railing fine cloth	Ceramicspinning wheels and textile tools
Northern and Southern Dynasties	Ceiba pentandra	Plaque cloth	Loom + jacquard
Sui and Tang dynasties	Boehmeria nivea	Gui cloth, dry cloth, tube cloth, Rongzhou Gongbu, Yulin Gongbu	loom
Song and Yuan Dynasties	Kapok, banana and hemp, bamboo, ramie, Ge, Jibe	Liubu, Xiangbu, Wuyuan bu, Jibei, Yao Banbu, Zi, and Guangxi brocade Ramie cloth, ge cloth, cloth, brocade, elephant cloth, jibb, rough ji bay,	loom
Ming and Qing dynasties	Ramie, cotton, kapok, udzu	Gebu, ramie cloth, linen, soil brocade	Bamboo cage machine
the Republic of China era	Ramie, kapok	Earth cloth, linen cloth, boy brocade	Bamboo cage machine
From 1949 to the present day		Tubu, Zhuang brocade	Drainage machine, bamboo cage machine, brocadexi brocade machine

Before the Republic of China, the raw material preparation process of Zhuang brocade had to be completed independently by the Zhuang women, which took up quite a long time in the early stage of the production of Zhuang brocade. In addition, the traditional raw materials of Zhuang brocade mainly come from the gift of nature, reflecting the dependence on and respect for natural resources. Therefore, in the traditional Zhuang brocade production. First of all, the fiber raw materials need to be planted, mainly including hemp, cotton, zu and other plants, in addition, silk is also obtained through silkworm breeding. Taking cotton yarn as an example, Guangxi cotton mainly includes two kinds of kapok and grass cotton. From cotton to spinning, it needs to go through planting, picking, seeding, elastic flowers, laying and other processes. After cotton spinning yarn is finished, it needs to be dyed. Traditional cotton yarn is dyed with plant color or mineral color, and the plant color is mainly indigo, turmeric, safflower, etc.; mineral colors are iron red, stone green, etc. The above raw materials can be made, red, blue, purple, black, yellow and other dyes. After entering the Republic of China, capital production gradually penetrated into the cotton textile market in Guangxi, and quickly replaced the traditional cotton textile model. In this process, Zhuang brocade artists also began to choose the industrial production of velvet raw materials, to replace the traditional hand-dyed yarn or silk thread, as the main material for their weaving. Until reform and open to the outside world, the domestic textile technology and market developed rapidly again, providing rich dyeing materials for industrial yarn and silk thread. Therefore, the colors of yarn and silk thread were constantly enriched, which provided many possibilities for the innovation and development of Zhuang brocade.

Guangxi Zhuang brocade The production process

The traditional Zhuang brocade technique mainly includes 15 processes, in order: leading line, finishing, reed, dressing, winding, machine, small yarn, large yarn, wearing jacquard, brazing shuttle, weaving edge, picking, cutting, opening, picking, walking and latitude. Before the starting leading line, it must also go through a series of preparatory processes such as spinning line, dyeing line and pulp line. It can be seen that a traditional Zhuang brocade takes about 160 hours to make, which not only requires the producer to be skilled, but also requires constant patience and perseverance.

With the process of industrialization, the production process of Zhuang brocade is optimized, and some processes are simplified. If you can buy the required colored velvet or silk thread directly from the market. Although the brocade machines in Guangxi are characteristics, the principle and technical characteristics of cross-stitch are roughly the same. Among them, Brocade Guangxi Zhuang Brocade Factory still retains the traditional brocade skills. Through the simplification of the process, it now mainly retains 8 processes of brocade (Table 2). The first process, spinning, in cotton or silk; the second process, in traditional plant color, usually in blue, red, yellow, black, green, and then design strong brocade pattern and color matching according to the existing colored cotton thread, the yarn with rice soup or powder; the fourth process, the fifth process, the third process, combing the yarn, combing warp and warp. The seventh process is brown and button, namely the warp and warp on brown seeds and buttons. In the eighth process, we weave various colors and patterns into colorful brocade (Fan & Wang, 2018, P: 45-51).



Table 2 brocadexi Zhuang brocade factory brocade process
 Source: brocadexi Zhuang brocade Factory provides 2/October/2023

In addition, the Zhuang brocade weaving is divided into two structures. One is the organizational structure of "three shuttles" (Figure 5), and the other is the organizational structure of "two shuttles" (Figure 6). Traditional zhuang brocade is mainly woven by the "three spindle method", that is, the first spindle is the flower latitude, the second is the ground pattern, and the third is the flat cloth pattern, which is continuously recycled (Zhang, 2006, P: 34). The ground latitude and flower latitude use untwisted velvet, and the cloth reinforce. It is tightly clamped and completely covered by the velvet ground pattern and pattern, and is completely covered without being exposed to the surface of the fabric, so the whole brocade surface presents exquisite artistic effect. The zhuang brocade woven by the "three shuttle method" is very beautiful and durable, but because it costs both labor and material, it is rarely used now. Now zhuang brocade generally adopts the "two shuttle method", that is, the first shuttle is flat, the second shuttle is the flower latitude, eliminating the ground grain latitude, and some of the raw materials used have also changed. Its artistic effect is no longer compared with the traditional brocade, which is relatively simple and not delicate enough (Tang, 2010, P: 122-124).

พหุบัณฑิต ชีเว

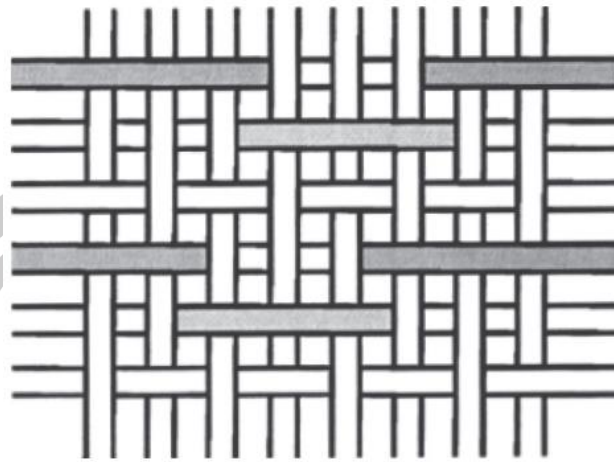


Figure 5 Organization structure of Zhuang brocade

Source: The Complete Book of Chinese Brocade, edited by Qian Xiaoping
17/January/2024

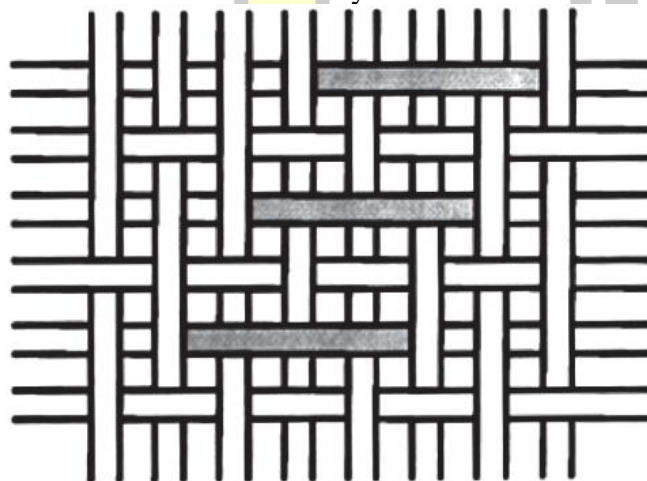


Figure 6 Organization structure of Zhuang brocade

Source: The Complete Book of Chinese Brocade, edited by Qian Xiaoping
17/January/2024

Part II: Guangxi Zhuang brocade History and development

Guangxi Zhuang brocade It is not only an important folk handicraft of the Zhuang nationality, but also a necessary textile for zhuang women's daily work, but also a living culture and memory carrier in the history of the Zhuang nationality. As a folk art, Zhuang brocade is rarely recorded in the official historical documents, so the birth and early evolution process of Zhuang brocade have disappeared in the long river of history. However, zhuang brocade has gorgeous colors, rich patterns and exquisite skills. Its materials, colors, patterns, skills and uses constitute the living carrier of "social memory", which contains a lot of memory information. The following analyzes and studies the information of "social memory" from two aspects of literature record and artistic value.

2.1 Reform and open to the outside world History of Guangxi Zhuang brocade (Han Dynasty-1978)

There are not many documents related to Zhuang brocade, and the basic veins and characteristics of Zhuang brocade can be found from the records of historical documents. Zhuang brocade usually in the period of social change, its function and value will change. Therefore, according to the historical stage, the phased research.reform and open to the outside world The history of former Zhuang brocade can be divided into: feudal society period (Han Dynasty 1840); semi-feudal and semi-colonial period (1840-1949); construction period of socialist period (1949-1978).

(1) Feudal Society Period (Han Dynasty-1840)

First, the Han Dynasty and the Tang Dynasty were the gestation period of the Zhuang brocade

Guangxi textile appeared for a long time. As early as in the archaeological excavation in Guangxi in the late Paleolithic Age, there were cultural relics unearthed with sewing tools (Institute of Archaeology of Chinese Academy of Social Sciences, 2003, P: 89), and the original pottery wheel (Chen, 2003, P: 15-21) unearthed in the Neolithic period, indicating that the original textile technology existed in Guangxi at the end of the primitive society.

In the Qin and Han dynasties, Guangxi was mainly inhabited by Xi'ou and Luoyue. After the first Emperor of the Qin Dynasty unified the south of the South, he adopted the policy of "moving people to guard the border and crossing the border". This period excavated tombs has been common in Guangxi pottery spinning wheel (Jiang, & Wei, 1878, P: 211), which found in the early western han dynasty tomb, unearthed hemp seeds, zeng, etc., has fully that they use ramie and hemp plants as textile materials, can weave "ge cloth, luo cloth, zeng cloth" cloth products such as clothing. In addition, there are textile tools such as warping knife, latitude knife, hanging tenon, mixing rod, spindle rod, winding plate, round rod, winding plate, winding rod, and cone nails unearthed in Luoobo Bay (edition of Guangxi Zhuang Autonomous Region Museum, 1988, P: 65). These tools are basically textiles that can be finished. Among them, the unearthed "black and red grain brocade" is the first physical evidence in the history of Guangxi brocade. The emergence of the back grain brocade may have the following information: first, the Guangxi your port luo bay han tomb report that the central plains (Guangxi zhuang autonomous region museum, 1988, P: 91), at the same time the tomb unearthed a large number of consistent with the original bronze, some scholars believe that the central plains trade items, so there are speculation unearthed in the tomb of brocade for the central product. Second, the tombs in the original records of zeng cloth, unearthed textile tools and seven buried pit unearthed "black orange back grain brocade" (figure 7), although part of the textile tools in the tools and the modern huanjiang area loom or brocade machine use tools, that the western han dynasty to modern Guangxi region has been from the original waist to oblique loom, but unearthed textile tools without recovery textile technology, failed to clear can weave what kind of cloth or brocade. To sum up, the burial objects recorded in the Black Land Orange Red Brocade and the wood slips include many textiles and wood textile tools (Museum of Guangxi Zhuang Autonomous Region, 1988, P: 86), marking the mature textile technology in Guangxi, China (Figure 8). In addition, the appearance of "Black Orange brocade" confirmed that the ancestors of

Zhuang in Guangxi had used brocade in the Western Han Dynasty, but it could not prove that the ancestors of Zhuang in Guangxi had mastered the brocade technology.



Figure 7 "Black ground orange back grain brocade" unearthed from the No.1 tomb of Robo Bay

Source: Qian Xiaoping, Shen Bei: Chinese brocade Daquan · National brocade. China Textile Press 2/January /2024

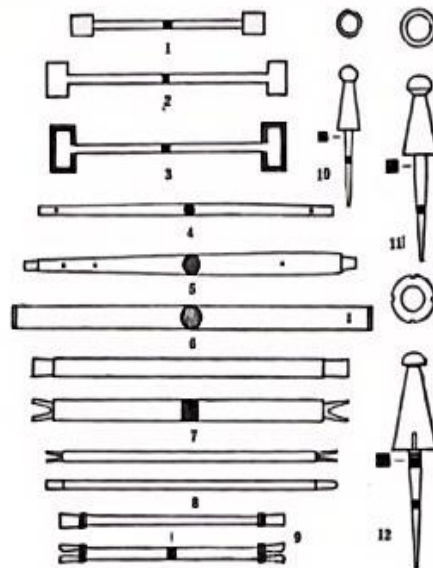


Figure 8 Line draft of textile tools unearthed from the No.1 Tomb of Robo Bay
Source: Guangxi Zhuang Autonomous Region Museum editor. The Han Tomb in Luobo Bay, Guigang, Guangxi. Cultural Relics Press 2/January /2024

In the Wei and brocade dynasties, the textile technology of the Zhuang nationality developed again. For example, it was recorded in Huayang Guozhi of Chang Qu in brocade Dynasty: " There are thin cloth. Appendices, liao said zhu also. Weaving it, such as silk and brocade."It shows that in the brocade Dynasty, the ancestors of the Zhuang people had the cloth woven with ramie like silk brocade.

The Tang Dynasty was an important period of ethnic changes in Guangxi, which began to change from West Locke and Locke to liao, Li and Hu. For example, volume 162 of the Song Dynasty cited the County State Annals of the Tang Dynasty: " Yangshuo County, Guangxi Prefecture, can weave grain cloth."Wu Hu is the zhuang ancestors. Later, in the Song Dynasty, the people in Guangxi gradually changed from barbarians and liao to servants. During this period, the textile industry in Guangxi entered a peak period of development, such as cloth and urban cloth in Guangxi, banana cloth and bamboo cloth in Rongzhou, spot cloth in Fuzhou, tubu cloth in Pennsylvania, cloth in Guizhou, tugong cloth in Yulin, and banana cloth in Hezhou. With the continuous development of Guangxi textile, the brocade in the Central Plains also entered a period of great reform. From the popular brocade in the Han Dynasty and the influence of Central Asian brocade, the brocade gradually changed to Wei brocade, after the development of flat brocade — Twill brocade — Twill brocade — Tang and Liao satin brocade. By comparing the Liao style satin brocade and the Guangxi Zhuang brocade, it is found that the diamond frame is relatively similar (Zhao, 2005, P: 217). In addition, a Tang Dynasty diamond brocade (Zhao, 2005, P: 218) was unearthed in Turpan, Xinjiang, with a white variant of Fang Sheng four-leaf pattern, whose pattern is basically similar to the skeleton of Guangxi Zhuang brocade pattern (Table 3). Although from the appearance of brocade used in Guangxi in the Western Han Dynasty to the literature records of "Guangxi brocade" in the Northern Song Dynasty, in the past 1,200 years, there were no written records and objects in all kinds of literature to prove that the ancestors of Guangxi Zhuang people used brocade or knitted brocade by themselves. However, through the above comparison, it is found that the Tang style and Liao style satin brocade in the late Tang Dynasty had a profound influence on the birth of Zhuang brocade in both the skills and artistic forms.




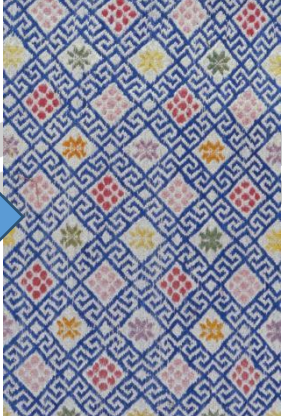

		
<p>It was unearthed in Astana, Turpan, Xinjiang, Tang Dynasty</p>	<p>Collection in the Palace Museum of the Qing Dynasty</p>	<p>Ten thousand words chrysanthemum brocade modern brocade gxi Zhuang Museum</p>

Table 3 Evolution diagram of brocade diamond pattern

Source: Yaocheng Tian, Author: 2024

Second, the Song and Yuan Dynasties period was the growth stage of Guangxi Brocade.

The birth of the zhuang brocade events, in the form of oral circulation in Guangxi folk social memory inheritance, memory of many stories about Zhuang brocade invention legends, such as the origin of the zhuang brocade "a zhuang brocade" "Harry brocade", "very rooster" three sister send bird clothes, such as the story of the inventor or the hero for women, milo armour, wang, fairy girl, mulberry and qiao ni, etc. From Zhuang brocade technology in folk, formed in the process of spread to "female — spider web inspired — weaving Zhuang brocade — transmission technology" cultural pattern, although the story in the process of transmission is often by the oral experience, cultural situation and the comprehensive influence of oral experience knowledge, but the story basic story contains the above elements. Another example is the origin of Zhuang Brocade. " According to legend, in the Song Dynasty, there was a Zhuang woman named Dani Mei, one day when she was thinking hard, she suddenly saw the light shining on the spider webs under the eaves, shining with gold, colorful, which inspired her. Since then, Dani sister has been in the traditional weaving technology, referring to the grain of spider webs, weaving a magnificent zhuang brocade. Around the women are famous, have for her weaving strong brocade marvel, and learn from her the techniques of weaving strong brocade. Since then, Zhuang brocade has gradually become popular in the Zhuang area, and the technique of weaving brocade has been passed down from generation to generation (Liao & Lu, 2012, P: 35)."For another example, although Yuan Dynasty Fei's book Shu brocade spectrum is a record of Shu brocade, it records the " Guangxi brocade " in the Song Dynasty in very few content, which is also the first time that Guangxi brocade has been recorded by official documents in history. Among them, there are four categories of brocade recorded in the transfer Academy: "shanggong brocade", "imperial brocade", and "Guangxi brocade", which is the first recorded "brocade" named after "Guangxi" in historical documents, and also the first record of "brocade"

in textiles in Guangxi. The above story culture is basically spread in accordance with the inherent cultural pattern. From the story and legends to the literature records, it can be presented that the "Guangxi brocade" woven by the official recruited military craftsmen is a monochrome brocade with patterns, and the folk brocade begins to explore and develop into the colorful Zhuang brocade.

In addition, "cloth" appeared in the Song Dynasty. It is recorded in Fan Chengda's "Gui Hai Yu Heng Zhi" that the cloth produced around "Liangjiangzhou Dong", such as Chinese brocadeluo, has a small square winning pattern. The silk fabric mentioned here has patterns, which is clearly fang Sheng grain, consistent with the later zhuang brocade decoration. Song people Zhou Laifei in the "Ling Wai generation answer" "take the door" recorded: " Yongzhou left and right river tong man, there are white, white matter square grain, Guangfu big wisp, like the line of the capital, and beautiful thick, sincere south of the service also."The folk began to appear with monochrome white square grain, indicating that the zhuang folk production of cloth in the Song and Yuan dynasties began to nationalization and nationalization. Can be found in the story of the song dynasty strong people aesthetic important turning point period, people are no longer meet the monochrome or color fabric, began to explore the cloth woven into the pattern, and basically formed in the story spread stable stable cultural pattern, as time goes on, in the process of innovation of successive brocade artists, eventually formed with the zhuang aesthetic needs art pattern. In addition, some scholars believe that "white matter square grain" refers to the zhuang brocade produced at that time. The decorative pattern is square geometric pattern, and its color is monochrome, which needs the support of follow-up literature and physical objects, so as to determine the relationship between "white" and zhuang brocade.

Third, the Ming and Qing Dynasties were the development period of Guangxi Brocade nationalization

During the Ming and Qing dynasties, the production and use of Zhuang brocade entered the peak period, which was also an important stage of the nationalization of Zhuang brocade.

① The birth of colorful Zhuang brocade

The color development stage of zhuang brocade in the Ming Dynasty. Ming Dynasty Xincheng brocade artist Man improved the brocade technology, the birth of the modern sense of zhuang brocade. In the "Xincheng MoShi genealogy" recorded the story of Moran's invention of colorful Zhuang brocade, " during the Moru ruling, Xincheng County brocade has been very popular. When he was in his 10s, he had learned and mastered brocade techniques from his parents. One day, when Moran went up the mountain to pick up mulberry leaves, he found the dew on the spider web in the morning light. So, Moman returned home to think hard, with colorful lines for latitude, primary color yarn for classics, finally invented the colorful zhuang brocade. Subsequently, Moman designed the lion rolling ball, phoenix wearing peony, double dragon play beads and other patterns of zhuang brocade. She knitted the color zhuang brocade is very popular, foreign merchants take the initiative to order. Moru's wife learned that Moran could weave a colorful brocade, and invited her to the yamen to teach technology. Moran was very generous, in addition to the yamen to teach technology, but also passed to other villagers. Since then, Xincheng zhuang brocade famous, the production scale of brocade has been rapidly expanded."Although the

story is still based on the birth of Zhuang brocade in the cultural schema to describe the birth of color Zhuang brocade, here there are several points to confirm the authenticity of the appearance of Zhuang brocade color brocade. first, Moran appears in the genealogy of Xincheng, Stories about her have been spread in different versions in Xincheng, There are also related remains of Mormaan; second, By using the description given in the story, The invention of the third generation of toast, And spread brocade techniques in the yamen, Also in line with the local official Moru in the "official pro retraining" put forward the "brocade can school system"; third, In the twenty-seventh year of Wanli of the Ming Dynasty, " Local officials paid a pilgrimage for three years, Give a tribute once... Guangxi Yungui tribute objects, Horse, rhinoceros horn, peacock tail, ivory, elephant hook, elephant saddle, elephant foot plate, boa snake bile, gold and silver vessels, sapphire, king stone, tent, gold wool, colorful wool, colorful cloth towel, flower rattan mat, incense, yellow wax, betel nut, All informal anywhere." Guangxi local officials have begun to pay tribute to all kinds of velvet, as tribute of colorful velvet, and colored velvet as tribute, has provided the raw material basis for the development of soil brocade color. Based on the above situation, the formation of colorful zhuang brocade should be formed in the Ming Dynasty. From the legend story to the literature records, we can basically determine the formation of Zhuang brocade experience, the Song Dynasty official production of "Guangxi brocade" —— white square —— the Song Dynasty folk production of the Ming Dynasty Xincheng brocade artist Man improved the brocade technology, the invention of colorful local brocade. It shows that Guangxi brocade experienced the initial single element brocade and gradually developed to the colorful zhuang brocade.

② The earth tribute of the Zhuang brocade

From the establishment of the chieftain system in the Yuan Dynasty to the gradual improvement of the Ming and Qing Dynasties, tu tribute was the local specialty of the chieftain to pay tribute to the feudal dynasties, and it was also a form of tax in the feudal society. Ming Dynasty " Hongwu example local officials three years of pilgrimage, tribute once." Therefore, the hereditary chieftains of Guangxi were also customized to pay tribute to the imperial court until 1915 after the return of the earth tribute. For example, in the 11th year of the Ming Dynasty (1638), Mo became the 11th local official. In order to protect his official position, he ordered to "present the soil" in the ninth year of Shunzhi (1652). He selected 8 "dragon and phoenix play beads", "lion rolling ball" and other exquisite pattern of earth brocade as tribute. Another example is the Daoguang eight years of the "Qingyuan Fu Annals" records: " Xincheng Tu County, the year to do soil brocade four colors, as long as twenty end, decoration silver 46 two a money zero, by the government solution pay salt method submitted, Daoguang three years in March." Zhuang brocade has become the normal behavior of tugong.

Now the earliest Zhuang brocade tribute for the national Palace Museum, the qing dynasty qianlong period of "dark brown geometric pattern Zhuang brocade is face" "camel color weave oblique word flower pattern Zhuang brocade is face" (Figure 9) "pink square wins grain back grain Zhuang brocade carpet", etc., with the Guangxi museum collection zhuang Zhuang brocade and modern zhuang folk zhuang texture, design, purpose is the same. With the unremitting efforts of the chieftains and brocade artists in the past dynasties, Zhuang brocade realized the development of soil

brocade from folk textiles to tribute, and at the same time accelerated the national development of Zhuang brocade and became a living fossil carrying Zhuang social memory.

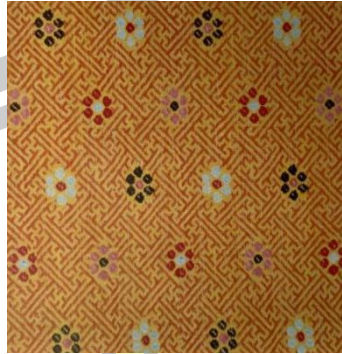


Figure 9 Zhuang brocade is collected in the Palace Museum of the Qing Dynasty
Source: The Palace Museum 10/January/2023

③ Promotion and support by local officials

In the Ming and Qing dynasties, Guangxi continued the chieftain system of the Yuan Dynasty, and continued to improve and developed vigorously. The predecessor of Zhuang brocade, "local brocade", also officially stepped on the stage of history. Under the promotion of local officials, Zhuang brocade entered the peak period of development. As recorded in the Genealogy of the Xincheng Mo family, During the reign of Emperor Hongzhi of the Ming Dynasty (1488-1505), mo Lu, the third local official, proposed the "brocade ke system" in the Re Training of Official Pro; During the reign of Emperor Jiabrocadeg (1522-1566), the wife of Mo Zongzhao, the 16th local official, mentioned, " Not yiqiluo, Only diligent textile "; During the reign of the apocalypse (1621-1627), the wife of Mo enda, the 11th local official, took "the work of textile personally"; The wife of Sergeant Mo Meng, The wife of Mo Zongzhao, the thirteenth local official, knitted brocade to sell, Make "a penny" (Pan, 2021, P:183-185). Zhuang brocade became the most popular textile at that time, which was directly related to the promotion of the local officials and the leading demonstration of their families. It was also inseparable from the personal participation of the local officials's wife and the dissemination of brocade technology, and also brought the soil brocade to the imperial palace, thus becoming tribute. At the same time, the development of Xincheng Zhuang brocade is the result of the invention and continuous improvement of the local people, and the active promotion of Tusi has also accelerated the development pace of Xincheng Zhuang brocade to a certain extent (Pan, 2021, P: 183-185). Finally, under the drive and promotion of the chieftain of the Ming and Qing dynasties, the production of brocade was encouraged, and Zhuang brocade became an important production material for the folk family workshops in this period, making the brocade technology more and more exquisite and its scale more and more large.

④ Ritualization of Zhuang brocade

Zhuang brocade become tribute after accelerating the spread of the folk, through the ceremony of life, quickly into the life of the zhuang people, in the full moon ceremony, the wedding ceremony become family love ties, not only expressed the zhuang people yearning for love and a better life, build the zhuang people essential memory material, become the zhuang people's pursuit of happiness

password. For example, Yan Sihui wrote in the third custom volume of Zhili Prefecture: "The dowry, the earth brocade must not be less, and everyone in his hometown can weave the reason. Soil brocade with willow velvet for it, with five colors, thick and durable, the value of 50 two, not ji daughter is to learn to weave." Zhuang brocade became an important part of the dowry, and its price is higher. Guangxu thirty-three years "Qingyuan Fu River Chizhou annals" volume three customs "Han custom marriage employment betel nut pig wine fruit, relatives, new women see aunt uncle shi Li, girls, mother's home to soil brocade as the baby, to silver circle, chicken reed to send xu home." Zhuang brocade as a harness is also widely spread in the folk.

In addition, the 33 years of Guangxu "Qingyuan Fu River Chizhou Annals" volume three customs "women for soil brocade, cotton as the classics, with five color velvet as the latitude, vertical and horizontal embroidery wrong, beautiful and strong, can be flower towel or flowers or figures or birds or animals or characters, with white cloth with pen and ink painting skillfully, and the number of the machine axis woven into wan." And the Qing Dynasty "Emperor Qing Gong "above the record" He County zhuang people, men and women flower towel wrapped head, silver circle, green clothes embroidery, female ring bun inserted silver hairpin. Dress edge, short shirt is pure cotton, gorgeous skirt. Since Xi can weave strong brocade and handkerchief. The man will carry a home weaver." Zhuang brocade has formed a typical artistic style of five-color velvet for latitude, and has been widely spread in the folk ceremonies of the Zhuang people, and has been accepted and recognized by the Zhuang people.

⑤ The commercialization of Zhuang brocade

With the end of the Song and Yuan dynasties and the function of the brocade for horse, the brocade began to transform from serving others to serving the strong people. The patterns and production of the brocade had been following the customs and habits of the strong people. For example, strong people can weave into flowers, characters, birds and animals and words, indicating that soil brocade begins to invent and create patterns in order to meet the consumption needs of the nation. At present, the earliest in Xincheng County, the late Ming Dynasty has been recorded. The prosperity of brocade industry is directly related to the improvement of Xincheng Moman brocade and the dissemination of chieftain organization brocade technology. In addition, the wife of the twelfth sergeant Mo Meng and the wife of the thirteenth local official Mo Zongzhao all weave brocade to sell, so that "a small servant with no money" (Pan, 2021, P: 183-185). It shows that the local lady takes the lead in brocade and promotes the enthusiasm of the strong people in brocade. To the Qing Dynasty Xincheng soil brocade production has been throughout the county, county women nine out of ten will weave soil brocade. Such as the 11th year of Qianlong (1746), Xincheng County Xiangwei day soil brocade (Zhuang brocade) for sale. It reflects that the output and quality of Xincheng soil brocade have been improved, and it has become a valuable fabric for the daily needs of strong people. Another example is the Jiaqing years (1796 ~1820), xincheng county alone has more than 130 brocade machines, the sound of brocade. Among them, Xincheng people Mo official children, Mo Zhen in his "Xincheng Bamboo branch words" described the busy scene of Xincheng brocade also:

In October, the mountain city lights, every family brocade to three more.
After the chickens sang, they listened to the sound of anvil and mortar.

As the soil brocade market popularization and expanding, records about Zhuang brocade also gradually increased, such as the famous qing dynasty educator, scholars, poets, influential in the history of Guangxi zhuang history and cultural celebrities, have "jiangnan wit" and "two Guangdong master" said the Zheng Xianfu experienced two generations of toast period, and good relationship with toast, in soil MuShiXi MrsJiang birthday was invited to do sequence, to XinCheng brocade art and weaver il, write a long poem "brocade female":

I am a guest of Zhicheng, not a brocade girl.

The cool wind is over the deep lane, and the machine sound is not fixed.

Sad young autumn, veins Huang Guzhu.

Biper this small home, the legitimate door.

A light shuttle, careful wisp.

Young and square sick teeth, as the fear cast zhu.

Look up without suspicion, no shame nor anger.

Looking at vrova.

The day is not a foot strong, the condition is three zhang xu.

Wen Xiang cover e jun, treasure worship hu.

But know the familiar guest hao, that know the cold female bitter.

A question an answer, if charming.

Home foot over the stream silk, is the Yanling xu.

Return to sing Wu Niang, Xiao Pu twilight square rain.

In the fifth year of Jiaqing (1800), brocade and others supervised the "Guangxi Tongzhi" recorded: " brocade states and counties, people love color, all is all take five color velvet, mixed with weaving for flowers and birds, far view quite clever and gorgeous, myopic and thick, expensive."The production of Zhuang brocade has developed from Xincheng to all states and counties, and the colorful Zhuang brocade has become a strong proof of strong people love color. In addition, Shen Rilun's "West Guangdong" wrote that Zhuang women " skilled, dyed silk brocade colorful, and silk, can be a mattress. All your officials and rich businessmen, never fight for them."Zhuang brocade's products have bed sheets, quilt surface, braces core, belt, bag, shoulder bag, head, apron, cushion, cigarette bag and so on. Arts and crafts patterns have "lion rolling beads", "double dragon play beads", "New Year red plum", "phoenix string peony", "four treasure basket", "all the best" and so on. These products, with cotton yarn as the warp, velvet for the latitude. With its exquisite shape, novel pattern, gorgeous color, exquisite weavers, strong and durable, it has a strong Zhuang characteristics and unique traditional art style. Under the promotion of tugong and commodities, zhuang brocade not only became a valuable textile for the strong people at that time, but also became a commodity rushed by expensive officials and rich businessmen to buy, which jointly promoted the prosperity and development of the brocade industry in Guangxi.

⑥ The spread of Zhuang brocade

Although the song dynasty Guangxi brocade has accompanied the horse trade route spread the brocade, the Ming and qing dynasties zhuang brocade into the formation and rapid development period, and Zhuang brocade also spread in Guangxi,

the Nanning long an zhuang brocade skills fifth generation inheritance Huang Yinglan, long an zhuang brocade in qing jiaqing fourteen years (1809) in four Lian Village more Dan tun rise (Lu, 2021, P: 119-121). This is a clear record of the time of the dissemination of zhuang brocade skills. In addition, it is said that the production of Binyang Zhuang brocade began in the Qing Dynasty, and the earliest one was the women of Liao Village, Wuling (Fu, 2013, P: 203-207).

(2) Semi-colonial and semi-feudal society (1840-1949)

After the Opium War, China gradually became a semi-colonial and semi-feudal society, and the Zhuang society of Guangxi was also deeply affected. With the dumping of western industrial products, the self-sufficient economic model of the Zhuang people was seriously impacted, especially to the textile industry of the Zhuang people. After the Sino-French War, the French imperialists took Vietnam as a springboard to transport commodities from Longzhou, brocadexi, Hekou and other places to the Zhuang area. Soon, Wuzhou (1897) and Nanning (1907) were opened. Since then, the imperialist bulk commodities, cotton yarn, cotton cloth, kerosene, fire music and other industrial products for the bulk, from Longzhou, brocadexi, Hekou and Beihai continuously imported to the Zhuang area continuously. In 1895, Zhang Liangui, governor of Guangxi, said, "There is no need for foreign goods." And Nanning has, Asia oil companies, specialized for the imperialist dumping kerosene, cotton yarn and cotton cloth. The vast Zhuang area has gradually become a part of the capitalist world market. By the beginning of the 20th century, the family textile industry in southeast Guangxi, the Zhuang area with convenient transportation, had collapsed. For example, your county "namely the small size of the scarf strip, also more to outsiders, the input of foreign yarn, and the textile industry gradually eliminated". People's clothes, most have been sewn with imported cotton yarn cotton cloth. Even in the mountainous areas of northwest Guangxi, where traffic is blocked, such as Donglan and Fengshan, capitalist commodities have gone deep, and the original household textile soil yarn is gradually replaced by imported cotton yarn (A Brief History of the Zhuang nationality, 1980, P: 80-83). And zhuang area has flourished valuable textile Zhuang brocade, in this period by a certain impact, but zhuang brocade brocade skills also get rapid development, such as guangxu 25 years (1899) "to shun Zhili state" mountains annals in three records: " soil brocade, a brocade, with silk cotton, colorful, luxuriant land, true poetry chart of waves, day Wu Zifeng also, state woven thick, town especially light, Jane." It shows that brocadexi is very exquisite, and zhuang brocade has also become the precious textile of the Zhuang people. The dumping of western cotton yarn has also reduced the preliminary work of Zhuang brocade spinning to a certain extent. So far, the brocade in brocadexi area is mostly woven for the purchase of ready-made cotton yarn.

After entering the Republic of China, although Xincheng was also impacted by the capital market, but the brocade industry in Xincheng area still retained the traditional family or personal textile production. Due to the high integration of Zhuang brocade and Zhuang society, the number of Zhuang brocade demand gradually increased, and the natural trade and market demand of the three days stimulated the production and trading of Zhuang brocade. Zhuang girls married, relatives and friends to send brocade is regarded as the most precious gift, because the strong family love, so the number of brocade people gradually increased, in the past Xincheng county more than 360 households, there are more than 200 weaving

brocade, to make a living, how many women have how many brocade machine. Xincheng Zhuang brocade society old worker Huang Aiqin said, in the past, her three sisters have three machines, every year after July and August, there will be outsiders to buy brocade, at that time in order to meet the needs of customers and day and night, the evening point tung oil lamp to brocade (Xing, 1990, P: 164). For example, in the first year of the Republic of China (1912), a "Delong" business name statistics, the annual sales of more than 100 zhuang brocade (Pan, 2012, P183-185). In the 22nd year of the Republic of China (1933), the annual output of about 2000 pieces (Xincheng County Annals Compilation Committee, 1997, P: 262). As the growing demand of Zhuang brocade, Zhuang brocade as a local local products began to participate in the fair, including " of 26 solstice of 7, in the national handicraft tour of the Guangxi Wuzhou exhibition, XinCheng residences Zhou Changxing mother of weaving'longfeng Zhuang brocade is face won a prize, have a certificate, a gold medal. In May of the same year, it was listed as the No.3 exhibit in Guangxi and selected to participate in the national handicraft exhibition. After being exhibited in Nanbrocadeg and Shanghai successively, it was purchased by American merchants with a large amount of money " (Xincheng County Annals Compilation Committee, 1997, P: 263). The exhibition has enhanced the reputation of Zhuang brocade and opened up a new direction for the sales of Zhuang brocade.

After entering the Republic of China, the influence of Zhuang brocade in Xincheng area continues to improve, not only loved by the Zhuang people in Xincheng, but also favored by the people of the surrounding ethnic groups. In 1921, women surnamed Jane in Xincheng County went to Chengdong Gate Street and Wang brocademing Village in Binyang County to teach the skills of weaving zhuang brocade. In 1935, at the age of 17, Liang Shuying, from binyang north alone to xincheng to lu women weaving Zhuang brocade craft, learn back to bin Yang, she kept the XinCheng traditional brocade skills, on the basis of combining the characteristics of binyang area innovation, formed with the characteristics of bin Yang bin Yang Zhuang brocade and teach to local women, and form scale development in binyang region. At the same time, the teaching of Zhuang brocade skills was spread and developed among Han women.

(3) The Construction period of the socialist period (1949-1978)

First, in the early days of the founding of new China (in 1949, October 1957) After the founding of the new China, the state implemented the ethnic policy of the Common Program, removing the tangible traces of ethnic discrimination left over in history; dredging ethnic relations; conducting ethnic identification; implementing regional ethnic autonomy; and guaranteeing the equal rights of scattered ethnic minorities. Through ethnic identification, on August 19, 1951, Longsheng Autonomous Region was renamed in 1955), including Zhuang, Dong, Yao and Miao. On December 10, 1952, the western Guangxi Zhuang Autonomous Region was established in the western half of Guangxi, where the Zhuang people live together. In March 1956, it was changed into an autonomous prefecture. Because zhuang is one of the largest minority ethnic population, in the long struggle with han, yao, miao, dong, people of all ethnic groups formed an inseparable flesh-and-blood relationship, the eastern Guangxi population, economically developed agricultural area and vast land, rich minerals in the western region, establish the provincial level autonomous region,

Under the guidance of the party's ethnic policy, we advocate the excavation and protection of ethnic folk crafts, and vigorously support the production of Zhuang brocade. Began in 1954 in Guangxi zhuang areas, brocade old artists restore Zhuang brocade production, and in Zhuang brocade production concentrated areas, XinCheng, binyang, brocadexi Zhuang brocade production cooperatives or production team, a professional production, key support, including binyang established "yu fu" brocade cooperatives, the brocade employees of more than 30 people, soon and several new cooperatives. At the same time, production cooperatives or groups of zhuang brocade or brocade have also been established in other urban streets and rural people's cooperatives in Guangxi. In 1956, the government of Binyang County merged several scattered brocade cooperatives such as "Yufu", and established Xinbin Town National Brocade Factory and Luxi Town National brocadexiu Factory. In the same year, the embroidery society was established in brocadexi County. In 1957, zhuang brocade production Association was established in Xincheng County, renting private houses as production sites to develop the production of Zhuang brocade. With the establishment of Zhuang brocade production cooperative, more and more experienced brocade artists contribute their strength to the collective production. The main Zhuang brocade products are bags, backpack heart, quilt surface and so on. During this period, under the promotion of national policies, Zhuang brocade changed from traditional family production to cooperative, and the team of brocade artists also expanded, so that the production of Zhuang brocade gained a new life (Table 4). In the same year, in the "National Ethnic Products Exhibition" held by Nanning District Second Light Industry, Xincheng Zhuang brocade won high praise, and was selected to Beibrocadeg to participate in the National Ethnic Products Exhibition (Xincheng County Annals Compilation Committee, 1997, P: 263).

area	creation time	name	product	property
brocadexi	In 1956,	Embroidery club	Zhuang brocade, embroidery	collective rule
	In 1960,	brocadexi Zhuang brocade factory	Zhuang brocade, embroidery	collective rule
Xincheng	In 1957,	Zhuang brocade production agency	Bag, vest belt, quilt surface	collective rule
	In 1975,	Xincheng Zhuang brocade factory	Bag, vest belt, quilt surface	collective rule
BinYang	In 1956,	Xinbin Town National brocade Factory	Bag, vest belt, quilt surface	collective rule
	In 1956,	Luxi Town National brocadexiu Factory	Bag, vest belt, quilt surface	collective rule

Table 4 Establishment statistics of Zhuang brocade Factory in Guangxi region

Source: Yaocheng Tian, Author: 2024

Second, the period of comprehensive construction of socialism (1958-1966)

Into the all-round construction of socialism period, the party and the government to carry out national policy, in depth after national identification work, at the same time according to the will of the people of all ethnic groups in Guangxi, Guangxi on March 5, 1958, held in Nanning autonomous region first people's congress meeting for the first time, officially announced "servant autonomous region" in Guangxi, and revoked the Guangxi zhuang autonomous prefecture, in the Guangxi province region established the provincial scope of the Guangxi zhuang autonomous region. On April 1 of the same year, Wenshan Zhuang and Miao Autonomous Prefecture was established in Yunnan Province. On September 26, 1962, Lianshan Zhuang and Yao Autonomous County was established in Guangdong Province.

On October 12, 1965, with the approval of The State Council to remove the tangible traces of ethnic discrimination, "Guangxi Zhuang Autonomous Region" was renamed "Guangxi Zhuang Autonomous Region". Looking back in history, when the zhuang nationality was recorded in the historical books, it was first used and changed to "servant" in the Southern Song Dynasty. Zhou Enlai, the first premier of the People's Republic of China, said "boy" to read "with" or "zhuang", easy to cause misunderstanding, so he personally approved and selected the strong "zhuang" word. Premier Zhou pointed out in a symposium in 1965 that the "servant" of the "servant" was the discrimination of the ruling class in the old society, and "servant" means "servant". Now the whole country is liberated, and the minorities and the Han are the masters of the country, etc. we should change the wrong view of the past. He also suggested that the "servant clan" should be changed to "Zhuang nationality". "Zhuang nationality" means strong, strong and full of vitality. He hoped that the Zhuang brothers would be strong and the Zhuang autonomous region would flourish. On October 12 of the same year, Premier Zhou Enlai's proposal was approved by The State Council, which officially changed the "servant family" to "Zhuang nationality". Accordingly, the "Guangxi Zhuang Autonomous Region" has also been changed to the "Guangxi Zhuang Autonomous Region". So far, with the completion of the name change of the Zhuang nationality, marking the birth of the name of the modern Zhuang brocade.

In the late 1950s, the country into the comprehensive socialist construction period, under the background of the implementation of planned economy, the party and the government is very concerned about the economic development of zhuang, vigorously cultivate a new generation of weaving workers, and in xincheng, binyang, brocadeg west three brocade factory selected zhuang brocade artists to Sichuan shu brocade weaving skills, then introduce can weave 1-1.2 meters wide "row machine" (Fan, 2015, P: 36-39). Under the guidance of the government, to help develop new markets, zhuang brocade transition from cooperatives to factory production, and at the same time, the people still retain family production, making the zhuang brocade production form a benign and sustainable development stage. After the introduction of "platoon machine" brocade machine, the production scale and economic scale of Zhuang brocade were rapidly improved. Among them, Binyang Zhuang brocade was once popular, and its products were exported to Denmark, Canada and other countries. In the 1960s and 1980s, the three brocade factories used machine suppliers as the main production tool of zhuang brocade products (Fan, 2015, P: 36-39). In addition, in 1959, the dragon and phoenix brocade produced by Xincheng Zhuang Brocade Society was sent to Beibrocadeg to participate in the 10th anniversary of

National Day "National Ethnic Minority manual Art Exhibition" exhibition and won awards. Xincheng Zhuang brocade "dragon and phoenix brocade" and "chrysanthemum brocade" weaver exquisite, exquisite patterns, chic, colorful colors, rich local ethnic characteristics, respectively collected by the National Cultural Palace of Nationalities and the Museum of Central University for Nationalities (Pan, 2012, P183-185). In addition, Guangxi Zhuang brocade began to enter the international market, exported to Japan, the United States, Canada, India, the Philippines and other countries and regions, well received by users.

Third, the "Cultural Revolution" period (1966-1976)

During the "Cultural Revolution" period, the destruction of ethnic customs and policies, forced ethnic minorities to change customs. When Lin Biao and the Gang of Four ran rampant, the legitimate customs of ethnic minorities were regarded as old customs and "four old" and "superstitious activities", which violated and interfered with the customs and habits of ethnic minorities. prohibit ethnic minorities to celebrate traditional ethnic festivals; prohibit ethnic minorities to wear ethnic costumes and jewelry and force the masses to modify the way of life as "bourgeois way of life" and suppress it. Influenced by the "Cultural Revolution", like the bronze drum, zhuang brocade was regarded as a symbol of "feudalism", "backwardness" and "ignorance". The government banned the production of zhuang brocade, and the sale of zhuang brocade was regarded as speculation. Therefore, under the high pressure of political ideology, the aesthetic image of Zhuang brocade was once denationalized (Cai, 2016, P: 5-9). At the same time, influenced by the wind of "breaking the four old", Zhuang brocade was said to be "black goods" of "seal, capital and repair". Zhuang brocade artists were criticized, enterprise production was destroyed, and Zhuang brocade skills entered a depression (Wei, et.,2017) 。 Although under the suppression of the "Cultural Revolution", in 1972, Xincheng County invested 10,000 yuan to buy the old office building of the county tax bureau to expand the factory building for Zhuang brocade. In the same year, the total export volume of Guangxi Zhuang brocade reached 100,000 yuan. By 1975, it was changed to Zhuang brocade Factory. However, during the Cultural Revolution in the 1960s, when the weaving of Zhuang brocade was strictly prohibited, the Zhuang people did not really stop the production and use of Zhuang brocade (Fan & Wang, 2011, P: 43-48).

2.2 Development of Zhuang brocade in Guangxi after reform and opening up (1978-2023)

After entering reform and open to the outside world, under the influence of the market economic system, the Zhuang ethnic groups in the early stage of socialist construction and the process of modernization after reform and open to the outside world, constantly changed their life style and aesthetic concepts.

In the late 1970s and early 1980s, Zhuang brocade complied with the rapid development of reform and open to the outside world hitch, and Zhuang brocade factories all entered the stage of rapid development of expanding plants and introducing new equipment. At the same time, the government has restored and advocated the production and use of Zhuang brocade, and it has once again become an aesthetic image with a national cultural color (Cai, 2016, P: 5-9). Into the 90s, Zhuang brocade production failed to keep up with the market economy development needs, the impact of modern industrial textiles and people need to change, caused the Zhuang brocade development pace struggling, product update slower, finished

product production is too high, gradually replaced by new products of market economy, Zhuang brocade industry development bottleneck and crisis. After 2000, the production of Zhuang brocade returned to the state of folk workshop production. In 2006, after the Zhuang brocade art became the first batch of national intangible cultural heritage, the development of Zhuang brocade ushered in vitality again. Since 1978 and 2023, Zhuang brocade has developed through twists and turns in various opportunities and difficulties. The rise and fall of Zhuang brocade is also the evolution of Zhuang culture and social memory. Through the social process of Zhuang brocade after reform and open to the outside world, the recovery and development of Zhuang brocade production in 1978-1990; the development dilemma and decline of Zhuang brocade in 1990-2006; the protection of intangible cultural heritage and inheritance of Zhuang brocade since 2006.

(1) Recovery and development of Zhuang brocade production in 1978 and 1990

Reform and open to the outside world After, the Zhuang brocade in the continuous construction and development. First, expand the production area, such as Xincheng Zhuang brocade factory in 1982, the Guangxi Zhuang Autonomous Region Ethnic Affairs Committee allocated 60,000 yuan, Xincheng County United Front Work Department support 5,000 yuan, in the Shuangsheng River peace bridge to build a 6 head of 3 floors of reinforced cement structure new workshop, construction area of 540 square meters. In 1985, Xincheng was identified as the key county of Guangxi Zhuang brocade production by the Guangxi Zhuang Autonomous Region. The Guangxi Zhuang Autonomous Region and relevant departments successively allocated 130,000 yuan to expand the plant and increase equipment, and established Xincheng National Zhuang brocade Factory on the basis of the original Zhuang brocade Society. At this time, Xincheng National Zhuang brocade Factory had 15 traditional bamboo cage brocade machines. Another example is Binyang national brocade factory, in 1981, the old and new looms have reached 98, the production of Zhuang, Yao, Miao, Dong and other minority brocade surface, sand release, hanging bags, wall hanging, etc., the product color of more than 100 kinds, sand release, hanging bags are exported to overseas. In 1982, Binyang national brocade factory staff has reached 122 people, Zhuang brocade became popular again. In 1983, in order to expand the production of Zhuang brocade, the Binyang County government divided the Binyang National Brocade Factory into two and established the No.1 Factory and No.2 Binyang National Brocade Factory (Table 5). In 1985, both factories achieved brilliant achievements (Fu, 2017, P: 203-207).

พหุ ม ประ โท ชี เว

Factory name	Number of employees (person)	Annual output value (ten thousand yuan)	scholarship and prize	remarks
Binyang national brocade factory no. 1	70	14.02	Zhuang brocade You Long was the face won the national Arts and Crafts Hundred Flowers Award	Produce 17 kinds of products
Binyang national brocade Factory 2	85	17.60	Zhuang brocade gong core won the Ministry of Light Industry quality products honorary award	

Table 5 In 1985, Binyang national brocade factory, two factory brilliant achievements

Source: Fu Guangning, "Discussion on the Opening and Utilization of Zhuang Brocade" 17/January/2024

By 1990, there were 21 employees in Xincheng, including 5 management cadres. However, due to the lack of liquidity, restricting the development of production, production is far from reaching the design capacity. In 1990, the production of 1878 sheets, 2662 pieces of braces, 2786 semi-finished products, 72 beds, the total output value of 13,900 yuan (Xincheng County Annals compilation Committee, 1997, P: 264).

Purchase of machinery and equipment, such as in 1983, the Ethnic Affairs Committee of the autonomous region again allocated 40,000 yuan for the purchase of various machinery and equipment, to expand the scale of production. After the renewal and transformation, there are 4 workshops of motor, spinning, spinning, discharging and weaving, with 128 sets of mechanical equipment, and the original value of fixed assets is 175,300 yuan. By 1987, five electric brocade looms were introduced, and the production efficiency was three times higher than that of the platoon loom. During this period, brocade products have quilt, sheets, hanging, pillow towel, curtain belt, tie, etc., strong texture, gorgeous color, loved by people. By 1987, the people's government of the autonomous region had invested more than 1.7 million yuan in the four brocade factories, built 8,000 square meters of factories, and purchased semi-mechanized equipment to replace most of the old "bamboo cage machines". The production of zhuang brocade products are mainly carry bags, backpack heart, noodles, etc., with the continuous improvement of product quality, zhuang brocade sales more and more wide, the number of more and more.

Third, International assistance promotes the development of Zhuang brocade Guangxi is implementing the policy of "opening up to the outside world and invigorating internally", strengthening horizontal contact and obtaining funding from international friends. Since November 1985, the European Agricultural Development Group sent Ben ismann, secretary general of the West German Agricultural Organization, and Charles Skinner, deputy Director of the Overseas Department of the British Organization, to visit Zhuang brocade Factory in Xincheng County. In July

1986, the representatives of the European Agricultural Development Group, John Bahrain and Anna Maria Bolin, visited Xincheng and gave them strong financial support. From 1987 to 1989, the British Oxford Relief Organization has made four grants amounting to RMB 371,000 yuan. The factory used this subsidy to purchase the motor group, platoon machine, lathe and other mechanical equipment to enhance the production capacity. The factory also allocated 89 drainage machines to the rural areas, Xintang, Panshui, Shangning, plate 6, Liren, free, new sugar, Longguang and other 8 Zhuang brocade production bases, to support the development of Zhuang brocade production. During this period, a number of excellent brocade experts such as Meng Xiaobrocade, Wei Shaohong, Fan Chunyan, Fan Meiyun and Zhou Liyun were cultivated, and the financial assistance played a role in promoting the inheritance and development of the Zhuang brocade cause in Xincheng. In 1992, the British Oxford Relief Organization decided to assist Zhuang brocade Factory in Xincheng County, Guangxi again to expand the reproduction of Zhuang brocade. Since then, Xincheng Zhuang brocade production began to embark on the socialized track (Pan, 2012, P: 183-185).

Fourth, the government organizes training to improve the brocade capacity Reform and open to the outside world, In order to better adapt to the market demand, in 1986 in order to improve labor productivity and meet the needs of the market, the government organization XinCheng brocade factory by going out to visit training, at the same time introduce 51.5 meters wide row of brocade machine, enrich the varieties of design and color, than traditional bamboo cage brocade machine power increased more than 3 times. In addition, in order to develop national brocade skills, Xincheng Zhuang Brocade Factory teaches skills through the inheritance of the masters and apprentices. The old artists Wei Guirong, Huang Aiqun, Lao Baozhen, Mo Aihua, Wang Yuying, Wei Lang Xi'an and other people teach solid skills. Mo Xiurong, as an advanced worker of the brocade factory, has been to other provinces and cities to learn and communicate.

Fifth, the government promotes and expands the sales path

Government continues to explore new market, outstanding brocade artists to Japan and other places show zhuang brocade skills, in October 1984 Liang Shuying invited to Tokyo rare textile exhibition exchange, and during the exhibition for folk cloth weaving performance, highly praised by the Japanese people and good evaluation of visitors (Pan, 2012, P: 183-185). In October 1988, Liang Shuying won the title of "Chinese Arts and Crafts Master" for his exquisite skills. As the second generation of inheritors of Zhuang brocade Society in Xincheng County, Meng Rujun passed the selection of national skilled talents in 1989 with her exquisite Zhuang brocade skills, and was appointed by the State Ethnic Affairs Commission to perform Zhuang brocade skills in Japan, which was well received by Japanese friends.

In addition, according to the records of Textile Industry Annals of Guangxi Tongzhi, from 1979 to 1995, the GDP of Zhuang brocade in Guangxi basically increased, but the occurrence of Zhuang brocade was the increase of output value only under the support of the government (Table 6). For example, in 1991, the zhuang brocade produced by the Binyang National Brocade Factory in the fourth National Traditional Ethnic Minority Sports Meeting became the designated product to increased the GDP of Zhuang brocade. After that, the production of Zhuang brocade

entered the unstable stage and gradually declined (Local Compilation Committee of Guangxi Zhuang Autonomous Region, 2000).

Unit: ten thousand yuan

a particular year	value of output	of a particular year	value of output	of a particular year	value of output
1979	47.05	1985	56.6	1991	75.3
1980	44.79	1986	55.1	1992	70.3
1981	48.5	1987	65.3	1993	31.3
1982	48.4	1988	75.1	1994	30.30
1983	48.2	1989	68.7	1995	123.71
1984	47	1990	39.95		

Table 6 The production value of Zhuang brocade in the whole area in 1979-1995
Source: Guangxi General Journal of Textile Industry 17/January/2024.

(2) Development Dilemma and Decline of Zhuang Brocade, 1990-2006

First, the market environment is changing

After 1990, with the continuous deepening of reform and open to the outside world and the rapid development of market economy, the competition in the textile industry has become increasingly fierce. Traditional textile as a labor-intensive industry, under the impact of modern industrial textiles, has not follow times development, especially need a lot of labor to weave the Zhuang brocade industry, many of the difficulties and difficulties, such as the production process, raw materials, equipment, professional talent shortage, Zhuang brocade failed to timely adapt to the social transformation and the needs of life change, cause Zhuang brocade product sales difficulties, shrinking, struggling. At the same time, under the guidance of the government, promote the participation in the international market. In 1992, the Ministry of Trade sent Xincheng Zhuang brocade works to Aba City, Okinawa, Japan to participate in the exhibition. The weaving technology of Xincheng Zhuang brocade once again became the highlight of the Japanese exhibition (Pan, 2012, P: 183-185). The brocade industry is increasingly depressed, the township run enterprises in the casual production, the county run brocade factory also quietly closed the door. As the origin of northern Guangxi Zhuang brocade, Xincheng Zhuang brocade factory has been closed down in 2006. At the beginning of liberation, only the brocadexi and Binyang ethnic brocade factories (Zhang, 2010, P: 123-124) have survived.

Second, the product upgrading is slow

With the improvement of people's quality of life and the diversification of consumer psychology, Zhuang brocade gradually declined after the 1990s. In 1972, Meng Rujun entered Xincheng Zhuang Brocade Factory with good benefits. Due to the complexity and difficulty of learning brocade technology, colleagues around him changed careers one after another. Meng Rujun became the factory director after a long time of technical training. However, with the development of society, concept change and industrialization process, the lack of modern zhuang brocade products with low output value is gradually replaced by modern popular weaving products. Due to poor sales of products, Zhuang brocade Factory was forced to stop production

in 1994, and Meng Rujun changed to a rice noodle shop (Lin, 2013). In 1999, Xincheng National Zhuang brocade Factory went bankrupt, and Xincheng brocade production once again retreated to the state of private individual workshop production. The products took the single production form of "strap core" to cope with the demand around Xincheng.

Xincheng Zhuang brocade factory has experienced ups and downs of the development process, forced by the development of Zhuang brocade market atrophy state, was forced to stop production in 1999, resulting in xincheng Zhuang brocade production back to the original workshop production state.

Third, the brocade equipment is backward, and then to restore the traditional brocade, low production efficiency

In the 1990s, brocadexi Zhuang brocade Factory once suffered a Waterloo, the traditional looms reduced to 3, the production scale declined sharply, leading to the reduction of the enterprise scale. In the factory building of brocadexi Zhuang brocade Factory, you can only see a few Zhuang brocade looms, and the loom is old and needs manual operation. The yield of pure hand-woven zhuang brocade is very low, and a very skilled weaver produces only one foot in a day, which greatly reduces the production efficiency. In 1995, the No.1 Binyang National Brocade Factory and the No.2 National Brocade Factory were merged into the Binyang National Brocade Factory. The woven brocade becomes the representative of Guangxi Zhuang brocade, its zhuang brocade patterns are numerous, novel design, bright colors, strong texture, with strong local ethnic characteristics and life atmosphere, the product patterns are mainly python dragon, big flower, bronze drum, longevity flower, etc.

The workshop of Binyang County National brocade Factory, due to years of wind and sun, the light is insufficient, the ground of the house is wet, and the outer wall has obvious traces of rain washing, relatively shabby. When the machines in the factory are old, most of them are the equipment from 1970 to 1989. The wooden bamboo cage machine and the electric jacquard cage machine are aging due to years of operation, and the machinery and equipment are far behind the modern brocade equipment.

Fourth, Zhuang brocade artists show an aging trend, with no successor.

After the 1990s, migrant workers in Guangxi went out to work. The brocade artists who had stayed at home were either invited away or went out to make a living. Through the visit, found that Xincheng, Binyang, brocadexi Zhuang brocade industry is facing the same problem —— The number of inheritors is decreasing. Most of the craftsmen in brocadexi Zhuang brocade Factory are middle-aged, with an average age in their 50s. Because most of the young people go out to work, it is difficult to see the young people in the loom, and the older generation also rarely participates in the brocade because of the opposition of their family. The family thinks that this kind of work needs a long time, which is not good for the lumbar spine, and the brocade for a long time will damage the eyes, which is not good for the body. In addition to the Chinese brocade craft master Meng Rujun and other 4 master zhuang brocade craft inheritors, handmade brocade people less than 8. Xincheng Zhuang brocade has been to "good people are hard to find, difficult to pass" "people die art" situation. Binyang Zhuang brocade with brocadexi, Xincheng, the same phenomenon of talent gap. The internal staff of the brocade factory is aging, and now there are only more than 10 employees, and their wages are settled by piece work. The income of

the "brocade people" under the government subsidy is only 1,000 yuan. The young generation of "brocade people" is hard to find, and it is more difficult to attract technical talents. The cultivation of inheritors has a long way to go. The era of "no young women learning to weave" has become history. brocadeg west Zhuang brocade factory director, Zhuang brocade factory training new work slow, new need a year or so to skilled loom, because the brocade technique is complicated and relatively complex, need to devote energy, no less than a mental activity, but low efficiency, income is not high, so cause young people are not interested in brocade art, and young, even if part of young people at first because of freshness, also insist on for a long time. For various reasons, Zhuang brocade technology falls into the dilemma of no successor in the process of development and inheritance (Qin, 2021, P151-155).

Fifth, the government to rescue and protect the zhuang brocade industry

In order to save the decline of zhuang brocade, the government of Guangxi Zhuang Autonomous Region has invested more than 7 million yuan since 2004, aiming to build Guangxi Institute of Arts and Crafts into the largest production base of Zhuang brocade and accelerate the industrialization development of zhuang brocade. Now the institute has a group of scientific research and technical personnel and folk craftsmen, introduced advanced scientific research and production equipment, and become the largest and strongest zhuang brocade research, design, development and production base in Guangxi and even in China. Zhuang brocade weaving technology inheritance, national arts and crafts master Tan Xiangguang, the introduction of young design talents, using a new generation of leading flower machine, introducing the modern design concept of traditional zhuang brocade weaving design, the production of scarf, shawl, backpack, handbag, pillow, umbrella and other elements of zhuang brocade supplies, these product design fashion, the price is relatively low. The institute has also established cooperative relations with some professional home textile factories, so that its new series of zhuang brocade samples can be put on the market as soon as possible to meet the growing market demand for Zhuang brocade products (Ding, 2013, P: 100-105).

(3) Protection of Intangible Cultural Heritage and Inheritance of Zhuang Brocade, 2006-2023

First, the formulation and introduction of intangible cultural heritage protection policies

Since 2003, the project has launched a project: In August 2004, with the approval of the Standing Committee of the National People's Congress, China joined the UNESCO Convention on the Protection of Intangible Cultural Heritage. The Convention emphasizes that intangible cultural heritage is " the tools, objects, arts, crafts and cultural sites of various groups, groups, sometimes individuals as their cultural heritage. With the change of their environment, the mutual relationship with nature and the change of historical conditions, various groups and groups constantly innovate the intangible cultural heritage passed down from generation to generation, and make them have a sense of identity and history, thus promoting cultural diversity and human creativity."In the same year, the Ministry of Culture and the Ministry of Finance jointly issued the Notice on the Implementation of Chinese Ethnic Folk Culture Protection Project and the Implementation Plan of the Protection Project of Chinese Ethnic Folk Culture; on March 31,2005, the General Office of the State Council issued the Opinions on Strengthening the Protection of Intangible Cultural

Heritage of China; in December, the State Council issued the Notice on Strengthening the Protection of Cultural Heritage; in May 2006, the Ministry of Culture published the first batch of 518 items of national intangible cultural heritage, then the first national Cultural Heritage Day was held on June 10. Under the leadership of the government and social participation, the protection of intangible cultural heritage is being carried out with great vigour across the country (Chen & Yang, 2009,15-19).

Second, in 2006, Zhuang brocade skills were selected into the first batch of national intangible cultural heritage protection projects

In the current development of economic globalization, due to the influence of modernization and foreign culture, Zhuang brocade is gradually losing its original living environment, and its survival and development, as well as living inheritance are facing severe challenges. In 2006, zhuang brocade art was identified as the first batch of national intangible cultural heritage projects. In 2010, the third batch of provincial intangible cultural heritage projects in Guangxi Zhuang Autonomous Region expanded the Zhuang brocade skills to Xincheng Zhuang brocade skills and Binyang brocade skills, so that the main brocade skills of Guangxi Zhuang can be included in the intangible cultural heritage projects and protected. The protection of Zhuang brocade intangible cultural heritage has become a research field of great attention, with many fruitful research results and monographs on zhuang brocade have emerged.

In summary, the above studies were obtained, The basic situation of zhuang brocade in Guangxi region is: Han Dynasty brocade technology introduced —— Wei and brocade development of jacquard earth cloth —— Tang Dynasty latitude brocade technology introduced —— the development of the Ming and Qing dynasties —— chiefdom nationality development and promote the soil brocade to become tribute —— return to the reform and open to the outside world, Zhuang brocade becomes the symbol of love, the symbol of wedding and the link of family love ——reform and open to the outside world Under the attack of the dual forces of market economy and globalization, —— In 2006, after the zhuang brocade technique became a national intangible cultural heritage, The Zhuang brocade has become a symbol of the Zhuang nationality culture, His identity is back on the board.

Part III: Guangxi Zhuang brocade, Cultural and art analysis

In the process of development, under the influence of Zhuang culture, Zhuang brocade has developed into an artistic symbol with the most characteristics of Zhuang culture. Since the Song Dynasty, the brocade art has been widely spread in Guangxi region, and by the Ming and Qing Dynasties, it has developed into the core item with symbolic significance in the life etiquette of the Zhuang people. The production materials, weaving techniques and patterns of Zhuang brocade have been handed down from generation to generation among Zhuang women, carrying and condensing the wisdom and aesthetics of zhuang women for thousands of years. To explore how Zhuang brocade becomes the "living state" carrier of Zhuang culture and art. The following is an in-depth analysis of the composition, color, pattern and culture of Zhuang brocade.

3.1 Composition analysis of Zhuang brocade Art

The pattern on zhuang brocade has experienced the process from monochrome to colorful, from simple to complicated. The earliest production was plain zhuang brocade with square patterns as the theme. It developed to the Ming and Qing dynasties. Zhuang brocade was colorful and magnificent. Various geometric patterns and animal and plant patterns were combined to make the composition and color design of zhuang brocade pattern reached an unprecedented level (Wu, 1986, P: 78-87). The composition of Zhuang brocade develops naturally from the national aesthetic, and the most basic composition form combines the pattern and graphic composition. These forms often produce ever-changing schema in the process of use. Through the brocadexi, Binyang, Xincheng and various museums for field investigation to collect zhuang brocade patterns. Zhuang brocade composition is divided into two types, one is the traditional geometric composition, the other is the innovative pattern composition.

(1) Traditional geometric composition analysis

The traditional pattern structure takes geometric pattern as the frame or ground pattern, and then filled with a variety of "main flower" patterns. The composition of traditional Zhuang brocade is mainly skeleton or shading, and there are mainly five types of composition forms: continuous geometric pattern type, composite geometric pattern type and plant pattern combination type, geometric pattern and animal pattern combination type, geometric pattern and text pattern combination type. Use two square continuous or square continuous spread the whole brocade surface.

One is the continuous geometric pattern type

According to the needs of the composition, the geometric patterns are continuously combined together to form a simple and clear, orderly arrangement, symmetrical and neat artistic pattern. It can be divided into two types: one is two square continuous geometric pattern, mainly diamond pattern, water pattern, mountain pattern, mostly used in the middle of the traditional surface or two stripes under the heart; two is four square continuous geometric pattern, mainly diamond, rectangle, square, hexagon, hexagon, octagonal and circle.

Second, the compound geometry pattern type

Geometry pattern together, constitute a complex geometry, such as in the strap design, often use composite double diamond pattern structure, the blank between the diamond filling or cloud lines, hook, word, lines, etc., unified coordination, numerous but not disorderly, brocade artist will image different lines hook and orderly visual effect, strengthen the artistic effect of Zhuang brocade. Composite geometric patterns are usually used in the strap surface and in the single to reinforce the main pattern.

Third, the combination type of geometric grain and plant grain type

The combination of geometric patterns and plant patterns is one of the most wonderful patterns in the art of Zhuang brocade. In the process of combination, plant patterns are usually filled in the center of the geometric patterns in the form of monomer, two groups of symmetry and four groups of symmetry, often as the leading role of composition. The different meanings of different plant patterns, influenced by the belief of flower women, the plant patterns add more auspicious meanings, such as chrysanthemum, million lines, fish pattern composed of the heart, which not only

symbolizes the original worship and reproduction of the Zhuang people, but also symbolizes the wishes of wealth, happiness and good wishes.

Fourth, the combination type of geometric grain and animal pattern

In the combination of geometric pattern and animal pattern, animal pattern is the main pattern. The geometry usually builds a two-square continuous or square continuous bone frame in the picture, and animal patterns fill it. The animal patterns are endowed with many auspicious meanings of happiness by the Zhuang people. In addition, the animal patterns are closely related to the totem and belief of the Zhuang people. As the folk saying goes: "Ten pieces of zhuang brocade, nine pieces of phoenix, live like phoenix out of the brocade."The phoenix pattern on the zhuang brocade is an idealized pattern image, its shape integrates the characteristics of peacock, brocade chicken and rooster, the noble and auspicious luck of the peacock, the phoenix pattern in the zhuang brocade contains the meaning of prosperity, wealth and good luck, as well as the meaning of asking for the shelter of the gods.

Fifth, the combination type of geometric lines and text lines

Auspicious words in Zhuang brocade usually have the effect of the finishing point, text as the core of the whole Zhuang brocade, text around with geometric patterns or other patterns, foil and strengthen the theme, make theme more distinct and prominent, through geometric segmentation and text, combined into a harmonious complete Zhuang brocade design, makes the composition is rich, and full of rhythm, strengthen the impact of the vision. For example, in the Zhuang brocade, swastitika and longevity lines are used more. The Swastika was originally a religious symbol, but was later pronounced by Wu Zetian as "wan", representing good luck and Wanfu brocade'an. And longevity lines represent health and longevity, peace and joy. Because zhuang brocade is made as noodles, become a dowry, so people prefer to use these two patterns.

(2) Innovative pattern composition analysis

Reform and open to the outside world Later, in the process of integration and development with The Times, there are new changes in the composition of Zhuang brocade, which can be mainly divided into four types:

One is the theme pattern

After encountering the development bottleneck, the development of Zhuang Brocade, promoted by the government and the non-governmental enterprises, developed the characteristics of the gift of Zhuang brocade and shaped the new image of Zhuang brocade. The giant Zhuang brocade was created around the theme, that is, the driving force for the innovative development of Zhuang brocade, and also an important force to promote Zhuang brocade to become the cultural symbol of the Zhuang nationality. Since 2004 "double wind toward the flower" zhuang brocade wall hanging, 2007 "to celebrate the 10th anniversary of Hong Kong's return" Zhuang brocade wall hanging, 2010 "Guangxi Zhuang brocade Expo" zhuang brocade wall hanging, 2019 "Zhuang Happiness Road" Zhuang brocade wall hanging, 2021 "Beautiful Zhuang brocade to the Party" zhuang brocade wall hanging, These giant wall pendants are used in major national events, Among them, "Guangxi Zhuang brocade World Expo" as a gift from the Zhuang people to the Shanghai World Expo, By the official permanent collection of the Shanghai World Expo, And won the Guinness World Record for the world's largest strong brocade.

Second, the zhuang nationality epic pattern

The Zhuang brocade wall hanging, "Exit the station" of the Zhuang ancestors overcome nature, overcome nature, this is the charm of the ancient Yue Xiong wind. "Water rhyme" Because the Zhuang nationality is a rice nation, the worship of the god of water, hope that the god of water does not drop flood, fish and rice harvest. "Reproduction" is the worship of the reproduction and the ancestors of the Zhuang ancestors, hoping to get the blessing by god by offering sacrifices to the gods, so as to achieve the good wishes of vigorous people and a strong nation. "Ancestor worship" is a scene where the Zhuang ancestors worship their ancestors. The bird symbolizes auspiciousness, and people put it on a very high position and worship it together with the souls of their ancestors. In the image of a tribal leader of the Western Vietnamese nation, people put all their hopes on him. Cattle is a totem of the Western Vietnamese nation and a symbol of wealth and strength. Yu Man is the worship totem of the Zhuang people, a flying fairy in myth, and a direct expression of ancient workers' yearning for freedom and light. After hunting, people danced around their prey, reflecting the production and life scenes of the ancestors of Xinluo. "Drum Wei" legend of the bronze drum can eliminate disaster, when people for rain, heaven, for god bless the powerful, rugged bronze drum. Based on the basis of the epic of the Zhuang nationality, these works absorb the patterns of bronze drum, Huashan rock paintings, plants, animals and other patterns, innovating the patterns of Zhuang brocade, making Zhuang brocade more closely connected with the Zhuang nationality. The Zhuang brocade has also become one of the representations of the Zhuang nationality culture.

Third, the folk life pattern

With the development of society, Zhuang brocade close to life, also draw excellent patterns from the folk life into the Zhuang brocade pattern, creation reflects the real life and social spirit, emerge many new Zhuang brocade pattern, such as sunflower to the sun, national unity, cotton harvest, fishery, Guilin landscape, revolutionary subject of Zhuang brocade, make Zhuang brocade pattern more rich and colorful. Such as "national dream —— song and dance weaving dream", "national dream —— sheng dance building dream", "Liu Sanjie", "March wind", "flowers and wealth", "national unity", "national customs" and other innovative folk life Zhuang brocade.

3.2 Color analysis of Zhuang brocade Art

Zhuang brocade is divided into two categories from the color: one is plain brocade, the other is colored brocade. From the weaving process, plain brocade adopts the weaving method of common longitude and common latitude, and the colored brocade adopts the weaving method of common longitude and broken latitude. The weaving method provides technical support for the colorful development of Zhuang brocade. There are three aspects: first, the source of the color, the combination mode of the color, the combination mode of the background color, and finally, the emotional expression of the color.

(1) The source of Zhuang brocade color

Traditional velvet colors come from plant dyes and mineral dyes. During the Ming and Qing dynasties, the ancestors of the Zhuang nationality used local plants or minerals to make cotton thread or velvet, such as madder to dye red, gardenia and turmeric yellow, and indigo blue. Zhuang people give full play to local wisdom, dye a variety of brilliant, high purity color velvet. After the Republic of China, under the

impact of the cotton textile market, the brocade industry used ready-made industrial velvet to weave zhuang brocade. At present, brocadexi Zhuang Brocade Factory no longer uses traditional dyed velvet, but uses ready-made industrial velvet. In addition, the appearance of industrial velvet in modern Zhuang brocade also enriched the color of Zhuang brocade, Zhuang brocade also appeared some clever and advanced gray brocade, is also quite popular in the market.

(2) Zhuang brocade color collocation way

Traditional zhuang brocade velvet influenced by dye, velvet dyeing is high degree and high purity of yellow, red, blue, green as the basic color, although zhuang people make zhuang brocade is commonly used subjective color, but in color collocation practice by the influence of velvet color, zhuang brocade color, create a colorful strong contrast color, so folk artists concluded "red with green, see good" color habits. The characteristic that zhuang brocade colour uses is: pay attention to the use of main tonal, see many color with little color, see colorful in simple and elegant, see rich in simple, color already gorgeous and dazzling, durable see again. A zhuang brocade is often composed of several colors or even more than a dozen colors. Due to proper configuration, it is gorgeous, rich and unified, harmonious, ancient and profound, and not vulgar (Pan & Qin, P: 503P: 503). Zhuang people more like heavy color, usually the colorful nature of color, after refining, generalization, exaggeration and even change color, strengthen the decorative effect of the pattern. For example, the design of Zhuang brocade wall, the combination of many colors and patterns, is very delicate, abstract and exaggerated. The color collocation shows the simplicity and diligence of the Zhuang people, and breaks through the conventional color matching scheme.

(3) The combination mode of zhuang brocade background color

Although "red and green, look not common" reflects the unique color matching of Zhuang brocade artists, but Zhuang brocade wants to be durable, Zhuang brocade artists also summed up another trick of color collocation of Zhuang brocade, Zhuang folk proverb says, " deep bright flowers look beautiful, shallow dark flowers are not ugly."(Chen, 1999, P: 54-55) zhuang brocade pattern usually is woven, and use strong color contrast, foil the theme pattern, zhuang brocade shading, usually using red, pink, camel, green, pure white, pure black, so on the dark or light color is easier to foil a colorful visual effect. The color matching and background color matching of Zhuang brocade are inherited from the artists of Zhuang brocade for thousands of years, forming the unique aesthetic ability of the Zhuang people and the color habit of using Zhuang brocade.

(4) The emotional expression of zhuang brocade color

Zhuang brocade is not at the beginning of the colorful embroidery, but has experienced a development process from simple to complex. Zhuang brocade in with zhuang, through colorful color, become the zhuang important emotional expression through the color reflects the zhuang people feel about things, and through the collocation of color and shade, to reflect their distinctive enthusiasm, bright and clear, brave, simple national character (Li, 2009, P: 187-188). As a handicraft with distinctive national characteristics of the Zhuang nationality, its color follows the people, which shows its free, lively and unrestrained style, and fully expresses the industrious, wisdom, bright and simple character of the Zhuang people (Liu, 2017, P: 16-19).

3.3 Pattern analysis of Zhuang brocade Art

Zhuang brocade pattern adhering to the traditional Chinese pattern "there must be intentional, intentional will be auspicious" cultural concept. Very heavy decorative pattern, its pattern theme rich, concise shape, abstract summary, in the composition of balanced composition, repeated change, simple change orderly, give people a unique shape, rich and unified, rich connotation, superb skills, is the crystallization of wisdom and emotional symbols of the Zhuang people. There are many Zhuang brocade patterns, among which the classification of patterns is different. This paper focuses on "social memory" and "traditional invention", and studies the use and implication of Zhuang brocade patterns: the main classification, one is the traditional pattern; the second is the innovative pattern, two types.

(1) Traditional pattern class

There are more than 50 kinds of traditional patterns in Guangxi, Then according to the purpose and meaning of the fraction, It can be divided into four types: one traditional geometric pattern includes diamond grain, square grain, circular grain, word grain, word grain, sun grain, water ripple, rope grain, woven grain, cloud grain, thunder pattern, feather grain, etc.; Two traditional plant lines have chrysanthemum pattern, kapok pattern, hibiscus pattern, osmanthus pattern, star anise pattern, pomegranate pattern, plum blossom pattern, etc.; Three traditional animal patterns include chicken pattern, chicken pattern, crane pattern, python dragon pattern, kylin pattern, tiger pattern, lion pattern, dragon pattern, deer pattern, cow pattern, fish pattern, frog pattern, butterfly pattern, swallow pattern, etc.; The four traditional combination patterns are double dragon play beads, double phoenix sunrise, lion rolling ball, butterfly love flower, fish jump, dragon gate, mandarin duck playing in the water and so on.

(2) Innovative pattern class

With the development of Zhuang brocade modernization and the needs of the market, Zhuang brocade pattern also keeps up with the development of The Times and constantly innovates. Innovation pattern mainly has two kinds, one kind is design innovation, mainly used for wall products, liu sanjie, horse, march wind, eight horse, rich, tonggu, festival harvest, harvest fish, Guilin landscape, old state landscape scenery, battle, water, reproduction, ancestor worship, great trust, soul, feather, ecstasy, drum, plum, orchid, bamboo, chrysanthemum, huashan, song, dance weaving dream (figure 10) and other themes wall hanging. Another example is the theme of a giant wall hanging for an activity or event, 2004 "Double Wind toward Flower", 2007 "celebrating the 10th Anniversary of Hong Kong's return" big wall hanging, 2010 "Guangxi Zhuang brocade, The World Expo" big wall hanging, 2019 "Zhuang Happiness Road", big wall hanging 2021 "Beautiful Zhuang Brocade dedicated to the Party" and so on. One is the innovation of patterns. The patterns extracted from the innovative patterns, such as flower basket pattern, copper coin pattern, embroidery pattern, feather pattern, feather pattern, frog man pattern, Liu Sanjie pattern, folk song duet grain, bronze drum pattern, feather boat grain, Huashan dance pattern, rock painting pattern, etc. Another example is Tan Xiangguang borrowed from the unearthed patterns.



Figure 10 Zhuang brocade: Song and Dance Weaving Dream
 Source: <https://banmo.com/renwu/3371.html> 17/January/2024

To sum up, it can be found that most of the zhuang brocade patterns are selected in life or patterns symbolizing auspicious happiness. They come from the life of the Zhuang people, their totem worship and their people's yearning for a better life. Therefore, zhuang brocade pattern is the tradition of history, dare to explore innovation, it is in the dual power, Zhuang brocade zhuang characteristic graphic language, become national culture, national beliefs, national customs intertwined artistic image, is reflecting the zhuang people love a better life and blessing memory symbol.

3.4 Cultural analysis of Zhuang brocade

The Zhuang brocade is rooted in the Zhuang cultural system. The Zhuang brocade pattern is integrated with the Zhuang totem culture, belief culture, folk culture and festival activities. At the same time, it is inextricably linked to the myths, legends, art and other cultural forms of the Zhuang nationality. Due to its long history, rich cultural connotation, strong national characteristics and unique aesthetic value, Zhuang brocade has become the representative of zhuang cultural characteristics and the cultural symbol of ethnic identity (Fan & Wang, 2011, P: 43-48). As the essence of national culture, the cultural significance of Zhuang brocade goes far beyond its practical function and value.

Analysis of totem culture

Zhuang totem worship has distinct characteristics, believing that the totem object of worship is the personified god, and it is related to itself. Common totems include flower totem, bird totem, dragon and snake totem, frog totem, cow totem and dog totem. All kinds of flower, bird, phoenix, ox, frog and dog patterns in zhuang brocade are all the traces of ancient totem worship and the image reflection of the inheritance of totem worship consciousness in the national culture. For example, the chrysanthemum grain zhuang brocade strap in brocadegxi is a metaphor for the "flower woman worship" of the Zhuang people. The flower beetle is the goddess of

the human birth. She gave birth to a girl, who gave birth to a boy. The Zhuang brocade woven with flowers is mostly used in the baby strap, hat and woman's mind to symbolize the respect and worship of flowers (Chen & Yang, P: 63-66). Before the 1990s, there were still many Huapo temples in the Zhuang area. In the past, Zhuang couples who had no children after marriage held ceremonies of "building Bridges for flowers" in order to seek their children. In the process of weaving Zhuang brocade artists, they call the geometric patterns as frames "bridge", and the independent patterns outside the geometric patterns "flowers" (Fan, 2015, P: 36-39). Many patterns of Zhuang brocade have been handed down under the influence of the Zhuang totem worship.

(2) Analysis of belief culture

The Zhuang did not have a unified religious belief, and the ancestors of the Zhuang believed in animism, which made the Zhuang belief worship have the characteristics of diversification and variation. The ancestors of the Zhuang people expressed their communication with nature through the worship of gods, in exchange for the gifts of nature and the yearning for a better life. In this long process, the ancestors of the Zhuang people formed the sun worship, thunder king worship, worship tree god worship, water god worship, fire god worship, land worship and ancestor god worship. Zhuang brocade patterns are mostly based on all things in nature. Influenced by the belief worship of the Zhuang nationality, many patterns related to the belief worship are born. For example, the ancestors of the Zhuang people worshipped the sun and respected the sun as god, with the custom of offering the sun to the sun. The sun pattern is the embodiment of the ancestors of the Zhuang people thinking about heaven and earth and the primitive life, and is the image expression form praying for the protection of the sun god. The patterns in Zhuang brocade, whether geometric or figurative, are vivid and exquisite, with rich changes and great connotation. These abstract and concrete patterns are highly decorative and are an essential part of Zhuang brocade (Zhang, 2013, P: 51-53).

(3) Analysis of folk culture

Zhuang brocade has many roles in the folk customs of the Zhuang people, such as Zhuang brocade as the bond of family love, the token of love, the gift of social network and the recognition of self-value.

One is Zhuang brocade as family bond, Zhuang brocade as two important attributes in life gift, one is the grandmother of the back, the second is the parents prepare dowry is face, at the same time Zhuang brocade also become an important media of grandmother and parents, Zhuang brocade become important gifts in the Zhuang society, become the important link of Zhuang social affection communication.

The second is a token of love. Zhuang brocade is also a symbol used by young men and women in the Zhuang society. Zhuang brocade was once the best way for Zhuang women to place their feelings. For folk songs, throwing hydrangea, engagement, having children..., they weave love and love, dowry, hydrand love, missing and love, longing and hope (Ma, 2007, P: 122-123).

Three is the gift of the social network, the Zhuang people see Zhuang brocade as good luck, happiness, every wedding, birthday, children full moon or Daji farewell activities, more magnificent Zhuang brocade as the best gift; young women often woven the most satisfied Zhuang brocade to their sweetheart, to express the purest love, meaning loyal love as beautiful and pure (He, 1997. P: 25).

Four is the recognition of self-value, people advocate the soul and beautiful female red girl with good craft is the most praised by everyone and the object of the pursuit of young men. The traditional folk customs of the Zhuang nationality believe that whether a girl weaver is delicate is one of the important signs to measure whether or not she is smart and capable, which has an important relationship with whether or not her life is happy in the future. Here, the female brocade technique has become an important condition for Zhuang men to choose a spouse (Peng, 2011, P: 4-7). Zhuang brocade pattern is a "symbol" of the life attitude of the Zhuang people. It tells the story on the fabric, the story of the Zhuang people communicating with nature and people in the long historical years, as well as the pursuit of beauty in their heart. It uses the traditional Zhuang brocade techniques to express their inner world with beautiful patterns. The pattern on the Zhuang brocade is considered to be the most direct embodiment of a "culture" of the Zhuang nationality. It represents an objective feature that generally appears in the Zhuang people, because this cultural feature continues among the Zhuang people, and is a carrier of the life, habits and psychology of the Zhuang nationality (Li, 2009, P: 187-188). The cultural characteristics of the combination of the formal Zhuang brocade pattern and folk customs have been continuously inherited in the Zhuang society, forming a unique Zhuang culture.

To sum up, Zhuang brocade culture and art originate from life and nature, from the totem worship of the Zhuang people, from the Zhuang people's yearning for a better life and the national psychology of seeking good fortune. Zhuang brocade as a representative of the Zhuang nationality symbol, it produced and developed in the Zhuang this group and community, cleverly put the nature of some form concise or exaggerated deformation, the image of the Zhuang history and culture, life form, customs into among them, will describe the object boldly induction and choice, make the graphic characteristic and has strong expression, form the characteristics of Zhuang graphic language, thus "social memory" highlights on the Zhuang brocade grain. For example, the myths and legends of patterns and mliua, the myths and legends of bird patterns and bultuo, the myths and legends of animal and plant patterns, and the connotation of Zhuang brocade patterns are linked with these myths and legends. For example, the pattern, bird pattern, feather pattern and ox pattern are closely related to ancestor worship, cloud and thunder pattern symbolizes the worship of thunder god, water ripple symbolizes the worship of the god of water, and octagonal pattern symbolizes the worship of the sun. These patterns reflect the Zhuang people's reverence for the gods, express people's hope for good weather, good grain and prosperous people, and express the nation's yearning and expectation for a better life.

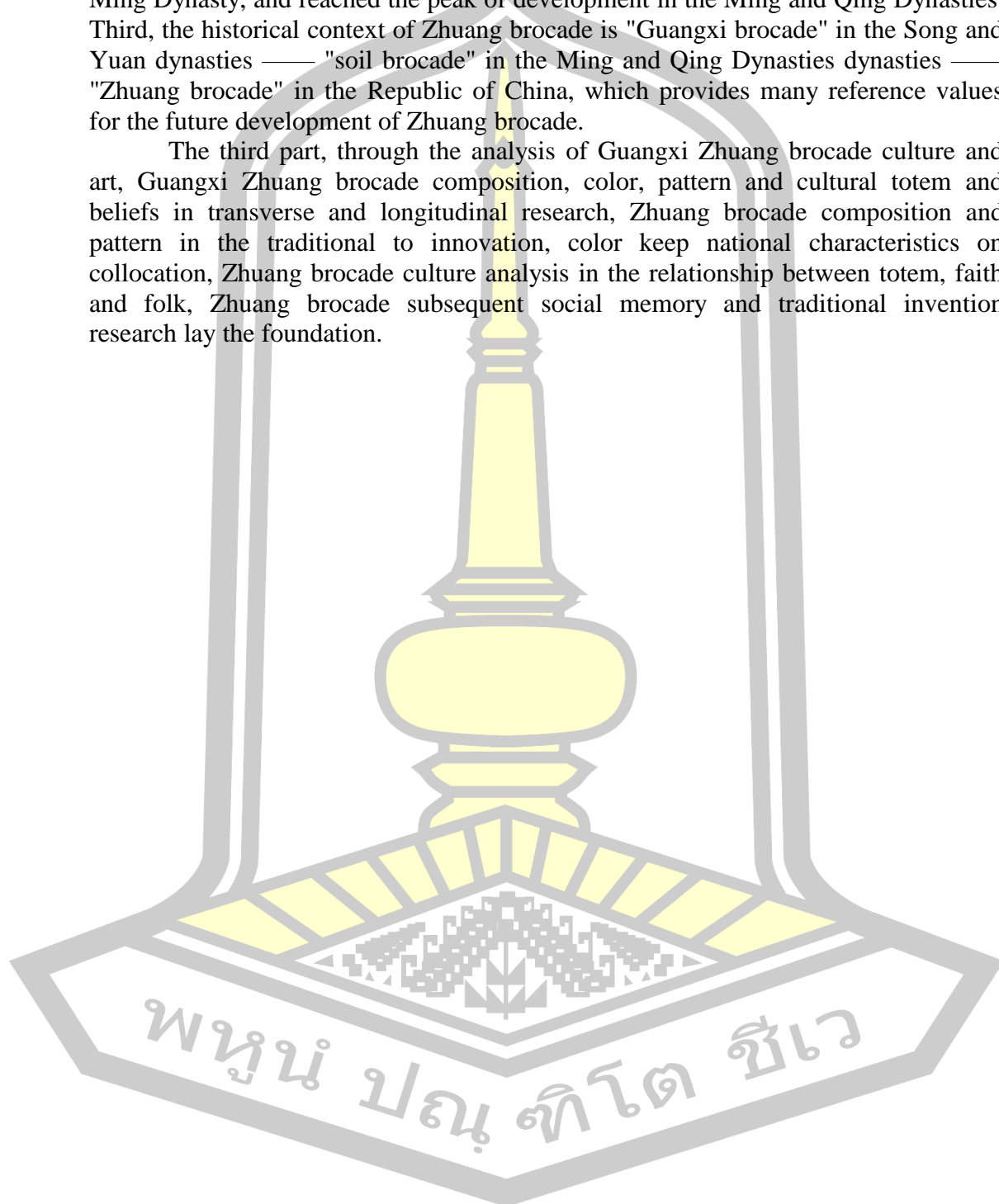
Summary

The first part, analyzes the historical and artistic value of Guangxi Zhuang brocade, through the literature and field investigation, mastered the original natural environment and cultural environment, combing the existing Zhuang brocade origin, combined with the history of Guangxi textile and Zhuang brocade production process, get new knowledge for Guangxi Zhuang brocade is in Guangxi natural environment and Zhuang ancestors created culture, along with the textile industry of Guangxi developed nationality, regional brocade art.

In the second part, the history of Guangxi Zhuang brocade was analyzed to acquire new knowledge. First, from the history of Guangxi textile, the Han Dynasty

brocade appeared in Guangxi, and it is clear that the brocade in the Han Dynasty was the input of foreign commodities. The second is to define the Zhuang brocade, making it clear that the modern Zhuang brocade was basically formed in the early Ming Dynasty, and reached the peak of development in the Ming and Qing Dynasties. Third, the historical context of Zhuang brocade is "Guangxi brocade" in the Song and Yuan dynasties — "soil brocade" in the Ming and Qing Dynasties — "Zhuang brocade" in the Republic of China, which provides many reference values for the future development of Zhuang brocade.

The third part, through the analysis of Guangxi Zhuang brocade culture and art, Guangxi Zhuang brocade composition, color, pattern and cultural totem and beliefs in transverse and longitudinal research, Zhuang brocade composition and pattern in the traditional to innovation, color keep national characteristics on collocation, Zhuang brocade culture analysis in the relationship between totem, faith and folk, Zhuang brocade subsequent social memory and traditional invention research lay the foundation.



CHAPTER III

The social memory of the Guangxi Zhuang brocade

This chapter answers to the second research goal. The second study objective was to study and analyze the "social memory" of Guangxi Zhuang brocade before and after reform and open to the outside world. The concept used in this chapter is "social memory". This chapter is divided into five sections. The first part is the Guangxi Zhuang brocade, the social memory in the historical documents; The second part is Guangxi Zhuang brocade, the social memory of Chinese totem and faith; The third part is Guangxi Zhuang brocade's social memory in the life ceremony; The fourth part is Guangxi Zhuang brocade, social memory in daily life; Part 5 of the Guangxi Zhuang brocade in the inheritance of the social memory.

Guangxi Zhuang brocade After one thousand precipitation, in the zhuang people's long-term labor practice, breeds Zhuang brocade rich and unique patterns, these patterns deeply embodies the zhuang people to life, nature and national culture of deep love and lofty respect, contains the optimism of national culture, carrying the people's vision, passed the sincere emotion. Zhuang brocade While meeting the basic needs of daily life, it perfectly integrates material practicality and spiritual needs to become a "living fossil" bearing the bearing of national cultural culture. Therefore, the academic concept of "social memory" is adopted to study Guangxi Zhuang brocade text from the perspective of historical memory. As required by the research analysis in the five chapters above. first, Study and analyze the written records of Guangxi brocade in historical documents, To extract the memory information carried by the written symbols; next, Through Zhuang brocade related legends and oral memory, Exploring the origin and development of Zhuang brocade; once more, Further analyze the social memory of totem and belief in Guangxi Zhuang brocade, The social memory of life ceremony, the social memory of daily life, the social memory of inheritance, To reveal how the Zhuang people had the social memory retained by Guangxi Zhuang brocade in different historical periods; last, Through multiple evidence, such as written symbols, oral memory and physical text, mutual corroboration, Dig deep into the real history and rich cultural connotation hidden behind the Guangxi Zhuang brocade.

Part I: Guangxi Zhuang brocade, The social memory in the historical literature

In the historical documents of Guangxi Zhuang brocade, the presentation of social memory mainly relies on three forms: written symbols, oral legends and physical text. The written symbols include two kinds of crowd records: one is the literature account of Zhuang brocade by the Zhuang people, and the other is the written record of Zhuang brocade by the Han people and other ethnic groups. Despite the various perspectives, the information base. In the evolution of the legend, the main body carrying Guangxi Zhuang brocade social memory is roughly divided into three groups: first, the Zhuang people inside and outside the Guangxi Zhuang Autonomous Region; second, the groups of other ethnic groups in the Guangxi Zhuang Autonomous Region; and secondly, the people outside the Guangxi Zhuang Autonomous Region. These groups inherit the legends and stories of Zhuang brocade. The physical text is mainly reflected in the brocade unearthed from Guangxi archaeology and the modern Zhuang brocade. Although the physical text does not

have the attributes of human memory, its patterns and the evolution of skills can assist or confirm the authenticity of written records and oral legends. Following is an in-depth analysis of the social memory of Guangxi Zhuang brocade in the historical literature.

1.1 Guangxi Zhuang brocade in the social memory in the literature

(1) Guangxi Zhuang brocade In reform and open to the outside world, social memory in the former literature

In a previous literature review, we have made a detailed combing and in-depth discussion of the relevant literature of Zhuang brocade documented in chapters I and II. Now, this paper will focus on the analysis and research of the detailed records of "Guangxi Brocade" in the Shu brocade spectrum in the Song and Yuan dynasties, and supplement the social memory and documents formed in the process of social history of Zhuang brocade from the Ming and Qing Dynasties to 1978, in order to have a more comprehensive and in-depth understanding of the historical evolution and cultural value of Zhuang brocade.

First, the memory of the documents recorded in the Song and Yuan dynasties

Although is about shu brocade records, but in few record about "Guangxi brocade", is the first time in the history of Guangxi brocade by official literature records, as an important document in the history of Guangxi brocade, scholars ignore the "Guangxi brocade" in-depth study, is often to literature direct reference or equivalent to Zhuang brocade in use, easy to produce academic research misunderstanding, from the perspective of social memory analysis "Guangxi brocade".

Shu brocade spectrum is an important historical material in the history of ancient Chinese textile, Written by Fei of the Yuan Dynasty, About 900 words, It records the details of the origin, production management, personnel allocation, brocade types, use and pattern of brocade in the sixth year of Yuanfeng, 1083), and the Southern Song Dynasty, 1126), Among them, there are four " called Shanghai tribute brocade, The official brocade, Yue minister liao coat son brocade, Yue Guangxi brocade ", It is the first time in historical documents that the "Guangxi" named "brocade", It is also the first time that "brocade" appears in textiles in Guangxi. The "Guangxi brocade" recorded in Chengdu Transfer in the Northern Song Dynasty is one of the important research objects of this paper. From the perspective of social memory, we will study and analyze the production population, production quantity, use and pattern of "Guangxi Brocade" in "Shu Brocade spectrum", so as to improve the historical research of Zhuang brocade.

To verify the authenticity of the documents recorded in the Shu brocade spectrum, Among them, Xie Yuanlu believes that Yuan Ren fee is based on the continuation of Chengdu Ancient and Modern Collection written by Wang Gangzhong in the Southern Song Dynasty and Yuan Shengyou's Chengdu Annals, while its indirect literature sources may be derived from Chengdu Ancient and Modern Collection written by Zhao Bian in the Northern Song Dynasty, It is basically confirmed that the literature is recorded from the Two Song Dynasty (Xie, 2005, P:21-26); In addition, Chen Yanshu, through the relevant records of Chengdu brocadeyuan in Lu Dafang's Records of brocadequan Building, Li Tao's Extension of History, and Lu Tao's Ten Records, Analyalyzed the data of Chengdu Fubrocade Academy and its annual output, It is confirmed that the content recorded in Shu brocade Pu has a high authenticity (Chen, 2019, P:104-108). At present, the research

on "Guangxi brocade" in "Shu Brocade spectrum" is not deep enough, basically stays in the stage of vernacular translation, or quoting a few words, "Guangxi brocade" as an important supporting document of Zhuang brocade produced in the Song Dynasty, or directly think that "Guangxi brocade" is Zhuang brocade, the discussion is everywhere.

First of all, "Guangxi brocade" production personnel analysis

It is recorded in "Shu Brocade Book" (Huang, 2013, P: 247-254), indicating that the production personnel of the Transfer Department Brocade Academy in the Northern Song Dynasty were military craftsmen recruited by the government. In the Song Dynasty, military craftsmen were usually craftsmen and were under the administration of the army. According to the use of the production of brocade and the group of military craftsmen, four types of registration, for the "upper tribute brocade, official brocade, official coat son brocade and Guangxi brocade". This can speculate that the northern song dynasty transfer division brocade courtyard in recruiting five hundred craftsmen, may be from different regions, and in the northern song dynasty period set wide west road hereinafter referred to as "Guangxi", one of the five hundred craftsmen is from guangnan road recruit brocade, so from guangnan road to recruit military woven brocade collectively referred to as "Guangxi brocade". The name of "Guangxi brocade" was produced because of the brocade craftsmen recruited by the government to transfer the brocade courtyard in Chengdu to produce brocade. Since the recruitment of military brocade is not recorded in detail, "Guangxi brocade" is the general name of the brocade of the ancestors of Zhuang, Yao, Li, Dong and other nationalities in the Northern Song Dynasty, which is not equivalent to any kind of existing brocade in Guangxi Zhuang Autonomous Region.

Secondly, the production quantity analysis of "Guangxi brocade"

It is recorded in Shu Brocade Pu that the transfer of Sibrocade Academy produces 690 brocade annually, while Guangxi Brocade produces 200 brocade annually, accounting for 29% of the total annual production of brocade yuan. Transfer of the four types of brocade produced by Sibrocade Institute, It produces 8 kinds of products, 3 kinds of products are the same as the products produced by Guan brocade, Guangxi brocade produces 6 products, Accounting for 43% of the total types of brocade production; In the production pattern, Guan Gaobrocade produces 8 kinds of patterns, The four patterns produced by Shanggongbrocade and Zibrocade are the same as those of official brocade, The Guangxi brocade produces five patterns, Among them, the true red male flowers and green male flowers are the same as a pattern, The patterns produced by Guangxi brocade accounted for 38.5% of the total patterns (Table 7). In addition, in the brocade products, Guangxi brocade clearly produces true red and green brocade. Through the analysis of the production scale, product types and pattern of brocade, it can be seen that "Guangxi brocade" plays a more important role in the production of brocade, and its production capacity and contribution capacity basically reach one third of the total production. This shows that most of the military craftsmen collected from Guangnan West Road were skilled brocade craftsmen, which reflects that there were many skilled brocade craftsmen in Guangxi during the Northern Song Dynasty.

time place of production	class	Production quantity	The proportion of production quantity	colour	Pattern name	type of production	Pattern types	The proportion of patterns
Northern Song Dynasty	On gong brocade	Three	0.4%	ahistoric	Eight answer halo brocade	A kind of	Eight kinds of	61.5%
	Official notice	400 Piece	58%	ahistoric	Ball brocade, cluster four golden carving brocade, sunflower brocade, eight answer dizzy brocade, six answer dizzy brocade, cui pool lion brocade, the world joy brocade, cloud goose brocade	Eight kinds of		
	Attentive coat brocade	87 Piece	12.6%	ahistoric	Clusters of four goldvulturebrocade, eight answer dizzy brocade, the world happy brocade	Three kinds of		
	Guangxi brocade	200 Piece	29%	True red brocade	Big nest lion brocade, big nest horse play brocade, double nest cloud wild goose brocade, appropriate male flowers brocade	Six kinds of		
Green green brocade				Appropriate male hundred flowers brocade, green cloud wild goose brocade				

Table 7 Statistical table of product quantity and pattern of transport department brocadeyuan

Source: Yaocheng Tian, Author: 17/January/2024

Thirdly, "the use of" Guangxi brocade " analysis

At the beginning of Shu brocade spectrum, it introduces the purpose of "paying the song tribute and the beginning of the song Dynasty". In the same period document "Records of brocade Guan Building", Lu Dabang detailed the purpose of setting up the brocade courtyard to dedicate the king and reward the subjects (Lv,2006.P: 210-211). After the southern crossing, "three years of construction, Da Masi began to weave brocade bedding and folded Lizhou and other places". The brocade produced was mainly used for the exchange of horses on the ancient tea-horse road. The three uses of brocade are basically defined; the exchange of materials. Is "Guangxi brocade" used for that purpose? It is clearly recorded in the Shu Brocade spectrum that the tribute king is the eight answer brocade, and there is no "Guangxi brocade", so excluding the use of "Guangxi brocade", "Guangxi brocade" is mainly the second or third use.

"Guangxi brocade" as the material of the Northern Song Dynasty. The "Guangxi brocade" produced by Chengdu brocadeyuan is the material for the costumes made by the king of the Northern Song Dynasty. First of all, the Song Dynasty had strict regulations on official clothing. In the early Song Dynasty, " Song because of the Tang system, three more than purple, five more than zhu, more than seven green, nine more than green."In the first year of Yuanfeng, to green, rank to four clothing purple, to six clothing fei, all like wat, fish, nine above green, wat to wood (Tuo,1977.P: 3561-3565). The true red brocade and green brocade produced from Guangxi Brocade are in line with the color requirements of the public service after the reform of Yuanfeng. In terms of color, Guangxi brocade is mainly used by officials who give five products to nine products. In addition, in the history of the Song Dynasty recorded: " Quan Zhongcheng, Kaifeng, yintai department, the trial court and above, the prosecution of the procuratorate, the three deputy envoy, the six unified army, brocade Wu general, red brocade. All classes and generals also gave narrow brocade robes. There are cui Mao, Yi male, Yunyan fine brocade, teacher, lian que, treasure to the big brocade, treasure to the brocade, fan seven (Tuo,1977.P: 3570-3571)."Among them, the red brocade used in the clothing includes appropriate male, cloud goose brocade, teacher, color and pattern and " Guangxi brocade " in the true red brocade in the big lion brocade, double nest cloud wild goose brocade, appropriate male flowers brocade pattern for a type. Therefore, "Guangxi Brocade" is mainly used for the costume reward of low-class officials, and its influence and technological level have not reached the level of serving Kings (Table 8).

พหุ ประถมศึกษา

name	colour	dermat o glyphic pattern	quantit y	When the clothing pattern	Official rank	Reward officials
Guangxi brocade	True red brocade	Big nest lion brocade Big nest horse big ball brocade double nest cloud wild goose brocade A hundre d flowers are suitable for men	100 Piece	Appropriat e male Cloud goose fine brocade Lion brocade	Five product s above	Quan Zhongcheng, know Kaifeng, silver, the court and to be made above, know the procuratorate , with the three deputy envoy, the six unified army, brocade Wu general
	Green green brocade	A hundre d flowers are suitable for men Green cloud goose brocade	100 Piece	Appropriat e male Cloud goose fine brocade	Seven product s above	All the classes and all the military generals

Figure 11 Statistical table of Guangxi brocade officials
Source : Yaocheng Tian, Author: 17/January/2024

"Guangxi brocade" as the material for southwest ethnic exchange horses. In the Northern Song Dynasty, Chengdu brocade mainly served the Kings, and its annual output was relatively stable. In the Southern Song Dynasty, the Academy determined the number of brocade according to the number of horses needed every year. After the southern crossing, the external activities of the Southern Song Dynasty increased by ten times. In the process of exchanging horses with the ethnic groups in the southwest region, the demand for brocade also increased rapidly. It is recorded in Shu brocade spectrum that in the Southern Song Dynasty, the tea Ma Si Brocade courtyard was mainly produced by Lizhou, Xuzhou, Nanping Army, Wenzhou and other places ". In addition, the "self-peddling and forbidden prosperity" showed that the places where brocade for horses were far more than above. In the Southern Song Dynasty, Guangnan West Road adopted the policy of controlling Yi, but most of these places were in the border areas of the Song Dynasty, and the ethnic composition was complex and often not effectively managed. At the same time, Hengshanzhai Boyi Field was mainly used for exchanging horses in Dali and southwest China. For example, in volume 16 of Guangxi, "Many people use more horses and brocade", Yongzhou bought more horses from the Luo Temple and worshipped themselves, "They was in Dali with brocade." In addition, according to the Records of Records that there are thousands of brocade and other textiles bought by Hengshanzhai officials every year. Although "Guangxi brocade" has no record of changing horses, Guangxi brocade may have spread with the trading route of Boyi Chang, and has been changed in private. For example, in the fine grain brocade produced in the Southern Song Dynasty, similar patterns are still spread in Guangxi, and there is a saying that "ten pieces Zhuang brocade nine pieces of phoenix, live like phoenix from the brocade".

As time goes by, "Guangxi brocade" has become one of the important commodities of tea and horse trade in southwest China. The change of its use has contributed to the wider use group and scope of "Guangxi brocade", and promoted the spread and circulation of "Guangxi brocade" between Guangxi and the ethnic minorities in southwest China. Therefore, in the demand of official reward in the Northern Song Dynasty, "Guangxi brocade" had a relatively stable sales channel and development time. In the Southern Song Dynasty, "Guangxi brocade" became one of the important commodities between the Kings and the minorities in southwest China. From the continuous use of "Guangxi brocade" in the officials of the Northern Song Dynasty to the spread and development in the southwest minority areas, "Guangxi brocade" later developed into Li brocade, Zhuang brocade, Yao brocade, Dong brocade, Miao brocade and Mao Nan Brocade. Finally, the pattern analysis of "Guangxi brocade"

There are many records of different types of brocade patterns, but the patterns produced by "Guangxi brocade" have been lost, and the spirit of these patterns is not seen. In the above article, the use of "Guangxi brocade" was mainly used for the role of public service or official service of the officials of the Northern Song Dynasty. Therefore, the production pattern of "Guangxi brocade" was determined by the official of the Northern Song Dynasty, and the colors and patterns of the brocade produced were produced in accordance with the ritual system. At the beginning of the establishment of the Northern Song Dynasty, the "Song Dynasty system" of the Tang

Song Dynasty, the formulation of official clothing and costume patterns should be influenced by the brocade pattern of the Tang Dynasty. In the big pattern lion brocade, the big pattern horse ball brocade and the "double pattern", the pattern structure popular in the Tang Dynasty is retained in the pattern skeleton, and the lion pattern, cloud goose pattern and horse pattern popular in the Tang Dynasty are retained in the theme. In addition, the pattern of Yinan flower brocade was also popular in the Tang Dynasty. Under the influence of the Northern Song Dynasty, the brocade pattern produced by "Guangxi brocade" still retains the style of the Tang Dynasty.

Through the in-depth analysis of "Guangxi brocade", "Guangxi brocade" cannot be equivalent to the current Zhuang brocade, but is the predecessor before the formation of Zhuang brocade. "Guangxi brocade" was influenced by the style and art form of the Tang style and Liao style satin brocade in the Central Plains, and had an influence on the birth of Zhuang brocade.

The second is the social memory recorded in the Zhuang brocade literature in the Ming and Qing Dynasties

In the Ming and Qing dynasties, the number of records about Zhuang brocade increased, mainly related to Zhuang brocade and folk customs. The above contents were also researched in the second chapter, which is not re-studied here. This article adds Ming Gu Yanwu "world county national benefit disease book": "flower skirt, men wearing a short shirt, name day Li bucket, waist before and after the knee, women also with Li bucket, under the flower curtain... men and women clothes are green, wax spots, style quite hua, but the leader with five color thread embroidery on the top. And qing fu heng in "huang qing gong" illustrated, recorded more detailed: "he county people: male scarf head, a silver ring, green embroidery, female ring through inserted silver hairpin, garment edge short, cotton skirt, China from xi, can brocade and cloth, the man with will be home from woven." Rong County people: men flower cloth wrapped head, women ornaments silver circle, clothes along the embroidery with brocade flower embroidery, with the brocade to sell, will take a hat." Xing'an County people: male blue cloth head, women bun silver hairpin, hanging with flower, beads, clothes along the brocade (Liu, 2005, P: 217-222)." (Figure 11) Records of Zhuang costumes and Zhuang brocade.

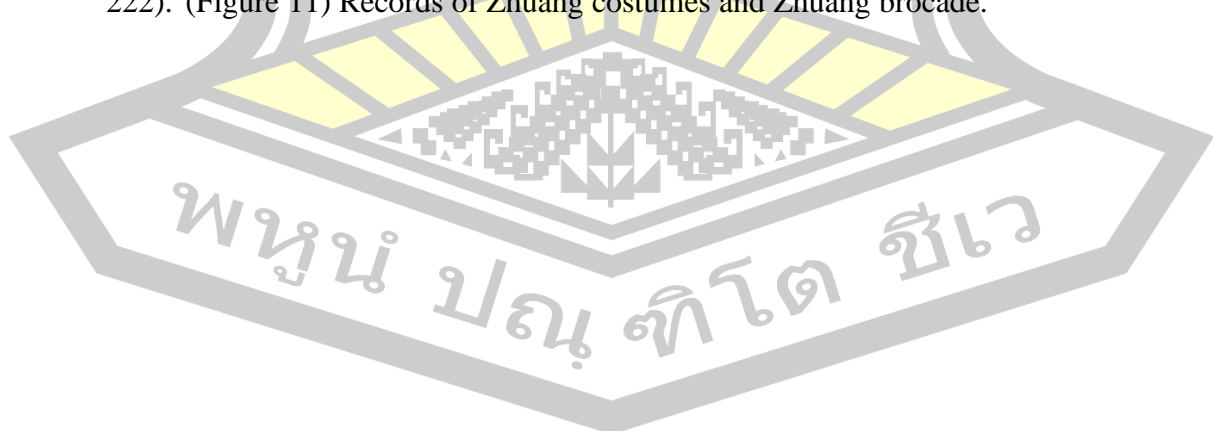




Figure 12 Zhuang people in the Qing Dynasty (one person on the right held Zhuang brocade in his hand)

Source: National Museum of China, National Museum of China Figure 17 / January / 2023

The third is the social memory recorded in the Zhuang brocade literature from the Republic of China to 1978

During the period of the Republic of China, the Zhuang brocade culture was further developed among the people. The Annals of Wuming County of the Republic of China recorded the close connection between Zhuang brocade and daily life such as Zhuang marriage customs. Poetry cloud: "Hundred future brocade section fresh, the painting hall is loud; the black box may not be many men wish, a flower towel early hanging shoulder (Tan, 2010, P: 136-137)." "The Republic of China" brocade Gxi County Annals "" custom "said:" male family betrothal gifts, as usual to send betrothal gold and pig, sheep, goose, duck, chicken wine seafood candy and other things. Female dowry is with brocade, bedding, curtain, shoes, socks, box, bowl and other things." "Until the 1960s and 1970s, in Xincheng, Yizhou, Hechi, Huanjiang, brocade Gxi, Napo, Longzhou, Daxin and other places are still along the traditional brocade, Zhuang brocade is the necessity of dowry.

(2) Guangxi Zhuang brocade in reform and open to the outside world, after the social memory in the literature

In 2012, Tan Liping felt in Binyang, brocade Gxi, Xincheng and other places that Zhuang brocade has become a "living fossil" bearing national cultural memory and one of the excellent cultural heritages of the Zhuang people (Tan, 2012, P: 48-51). In 2012, Huang Runbai summarized Zhuang brocade as "Zhuang brocade culture" in the "Analysis of Zhuang Culture inheritance and development path", which is one of the excellent cultural heritages of the Zhuang people. Zhuang brocade art has become an important part of the traditional folk skills in China (Huang, 2012, P: 46-50).

1.2 Guangxi Zhuang brocade, the social memory in the oral legend

As a kind of collective social consciousness spread spontaneously spread among the people, legends stories spread through the crowd and inherited from generation to generation, forming a basic and fixed cultural schema. The formation of legendary stories is often a cultural schema constructed in a specific social environment, which is the driving force of social memory inheritance. The oral memory of Zhuang brocade includes the following types: first, the invention of Zhuang brocade; second, the legend of Zhuang brocade and fairy; third, the legend of Zhuang brocade and toast; fourth, the legend of Zhuang brocade.

(1) Guangxi Zhuang brocade Invention legend

Guangxi folk retain many Zhuang brocade inventor legend, these inventors are mainly women, including Dani sister, Kang Mei sister, fairy girl, strong sister, etc., not only expressed the zhuang people's yearning for love and a better life, but also reflects the zhuang women intelligent, kind, hardworking and capable image. Such as the folk stories "The origin of Zhuang brocade", "Dani Guanyang brocade", "Moran invention color brocade", "strong sister innovation soil brocade" and so on.

"The Origin of Zhuang brocade is widely circulated in Guangxi, and this article has collected four different editions. From Zhuang brocade technology in folk spread, formed in the process of spread to "hero my sister —— female —— spider web inspired —— weaving Zhuang brocade —— transmission technology" cultural schema, although the story in the process of transmission is often by the oral experience, cultural situation and the comprehensive influence of oral experience knowledge, but the story basically contains these elements.

The first one is the story recorded by Zhou Zongxian in the article "The Magnificent Zhuang brocade". "Legend has it that in the Song Dynasty, there was a strong woman named Dani Mei. When she turned cotton into yarn and began to start weaving, she thought, what kind of cloth to weave? Can't weave the same cloth every year! She sat under the eaves and thought hard, from the moon to the moon, and from the sun. Suddenly, the light of the red sun shines on the spider webs under the eaves, glittering, beautiful as color painting. Her heart immediately opened the body, quickly moved the loom to the eaves, against the spider web a line to weave up, weave ah weave ah, finally woven into a beautiful brocade. When the news spread, all the strong women came to learn brocade from Dani sister. Since then, Zhuang brocade has become popular (Zhou, 1980, P: 38)."

The second part is Tan Xiufang recording the story in "poetic painting (prose)", "about the origin of Zhuang brocade, she has heard of such a beautiful and moving legend. In the Song Dynasty, the ancient Zhuang township —— Xincheng, there is a clever, named Dansister Zhuang girl, since childhood love fang move, can weave good embroidery. She often thought: how can you finish weaving the cloth better? Think, think! From the moon hanging trees slightly think of the moon sinking in the western mountains, from the moon setting and think of the eastern sun red, hard thinking, still can not come out. One morning, she came to the cotton field branches, is trying to be absorbed, suddenly found in the cotton branches of the spider webs above, condensing countless crystal bright dew, was the rising sun shining golden, dazzling, as if in the crisscross silver decorated with pearls, very beautiful. Dani sister was influenced by this moving scene. I thought, how beautiful this beautiful grain on

the cloth. When she got home, she knitted a line on the loom. Weaving ah, weaving ah! Finally woven into a brocade. Later, the neighboring social women knew that they all came to learn from her. Therefore, Zhuang brocade was spread in the Zhuang people and passed down from generation to generation until today (Qin, 1980, P: 115-116).”

The third part is Liao Mingjun, and Lu Chun included the Origin of Zhuang brocade in *Guangxi Embroidery Culture*: It is said that in the Song Dynasty, there was a Zhuang woman named Dani Mei. One day, when she was thinking hard, she suddenly saw the light shining on the spider webs under the eaves, which inspired her. Since then, Dani sister has used the traditional weaving technology to reference the spider web grain, weaving a magnificent Zhuang brocade. Women around the famous, have to marvel at her weaving Zhuang brocade, and learn from her the technology of weaving Zhuang brocade. Since then, Zhuang brocade has gradually become popular in the Zhuang area, and the brocade technology has been passed down from generation to generation (Liao & Lu, 2012, P: 33).

The fourth part is recorded by Qian Xiaoping in the *Complete Book of Chinese Brocade*, and the legend of "DanGuanyang Brocade" spread in Tian'e area of Guangxi. According to legend, in the early years of the Song Dynasty, a Zhuang woman had an expert in weaving cloth, her name was Dani Mei. Dani sister weaving has a characteristic, like continuous innovation. Once, in order to conceive a new pattern, she sat on the threshold, staring at a spider web under the eaves, thinking hard, from sunrise to sunrise, thinking for a whole day and a night has not wanted to come out. When she was about to get up and leave, suddenly saw the spider web covered with water, in the morning sun showed colorful, golden colors, very beautiful. In this way, Dani sister got inspiration, immediately moved the loom to the eaves, to the spider web, with colorful silk thread woven up. Less than half a day to weave a piece of bright if red, beautiful as rainbow brocade. The news spread, around the Zhuang weaver came to learn from Dani sister. Since then, Zhuang brocade's technology has been circulating everywhere (Qian, 2014, P: 3).

In brocade also spread another version of the Song Dynasty Zhuang brocade produced the story. It is said that an emperor of the Song Dynasty had a palace maid named Kou Mei, who was born beautiful. The crown prince wanted to insult her, so she escaped from the court and traveled from Bianliang to the frontier. A Zhuang woman was very kind to her, asked her to eat and live, Kou Mei and the Zhuang woman became sisters. Kou Mei originally learned in the court brocade craft, brocade technology taught to the Zhuang women, from then on brocade began to produce in the Zhuang township, Zhuang brocade welcomed by the masses. The Zhuang nationality girl, in order to get along with her day and night, did not get married (Bao, 1987, P: 135-138).

The invention of Zhuang brocade in the Ming Dynasty still evolved in the above cultural schema, from a combination of thousands of Zhuang women to real characters. For example, the story of "Xincheng Man invented Color Zhuang brocade" and "Strong brocade" has undergone a new evolution, and its evolution also occurred in the transformation process from Guangxi brocade in the Song and Yuan Dynasties to the earth brocade in the Ming and Qing Dynasties. The earth brocade in the Ming and Qing dynasties was an important period for the nationalization of Zhuang brocade, and also the real formation period of Zhuang brocade. The story characters

in this period were not legendary, but real existence. The following two true stories, one is Xincheng Man invented color Zhuang brocade, the other is Xincheng, strengthen sister innovation soil brocade, basically explains how Zhuang brocade in the Zhuang area generated information.

Xincheng Moman invented color Zhuang brocade, is according to the "Xincheng Moshi genealogy" about the Ming Dynasty Moman invention of color Zhuang brocade records, handed down to this day."During the Moru administration, the brocade in Xincheng County was already very popular. When Mormaan was in his 10s, he had learned and mastered brocade techniques from his parents. One day, when Moran went up the mountain to pick up mulberry leaves, he found the dew on the spider web in the morning light. So, Moman returned home and then thought hard, with colorful lines for latitude, primary color yarn for the classics, and finally invented the colorful Zhuang brocade. Subsequently, Moman designed the Zhuang brocade of lion rolling ball, phoenix wearing peony, double dragon playing beads and other patterns. She woven the color Zhuang brocade is very popular, foreign merchants take the initiative to order. Moru's wife learned that Moran could weave a colorful Zhuang brocade, and invited her to the yamen to teach technology. Moran is very generous, in addition to the yamen to teach technology, but also passed to other villagers. Since then, Xincheng Zhuang brocade famous, the production scale of brocade has also expanded rapidly."At the same time, there are two other versions of Moman's invention that clearly record Moman's life and related stories.

Another for Qin Guiqing's book "Xincheng Tusi history" in the record of "strong sister innovation soil brocade": it is said that more than 400 years ago in the Ming Dynasty, xincheng Tu County Zhuang mountain village, there is a smart and capable Zhuang elder sister, to the field to pick up cotton, saw a spider in the cotton tree spit silk web. She thought, the spider spit silk to weave a gossip net, if the yarn imitation to weave a gossip shaped flower head (the pattern), must be very beautiful. The elder sister tells the sisters his idea, everyone all approve, so she did stretch frame, the white cloth tight on the rack, with blue line embroidery gossip sample picture, embroider a spider on the gossip, named string spider even, this is the first brocade of zhuang family. The sisters saw the novel earth brocade, are very like, running to tell each other, good news soon spread throughout the village, everyone praised the strong sister dare to think will do, Zhuang elder sister saw their ideas to realize, the heart sweet. However, she was not satisfied, but also wanted to make the earth brocade better to look at.

Another morning, my sister went to the cotton field and saw spider webs covered with dew, dew in the rising sun, shining colorful light, see the scenery, and caused her wonderful association: if a variety of color silk thread to weave colorful head, it will make the brocade more colorful and beautiful. Growing elder sister and sisters, elaborate design, the shiny silk into various colors, the loom converted into brocade machine, with color silk thread for weft, with white or blue thread for line, woven into colorful new brocade, color new glittering, lifelike, attracted bees to see splendid, butterfly flying flowers, nearby village fort zhuang sisters to watch brocade, to grow elder sister learn brocade craft, growing elder sister carefully teach technology, and encourage everyone to think more, le ring mill, dare to innovation, constantly improve technology and increase design and color varieties. Sisters listened to all understood, some edge eat longevity fruit (also called chicken fruit)

copy the shape of the fruit, draw big, small words, some to the pomegranate imitation embroidery pomegranate flower, some pick out "phoenix peony", some draw "butterfly", some embroidered "lion ball", some weave "four treasure" (sword) basket ", some draw" flying gold wire ", and "small butterfly" small wave ", big and small plum flower head (Qin, 1990, P: 162). At the same time, Qin Guiqing in the interview with Xincheng Zhuang brocade club more than 70 years old old worker Huang Aiqin said: more than 100 years ago, more than ten miles away from the county seat Gao Yang (now Luo) ancient Shang, there is a surname Luo old milk will play a string of spider head, confirmed that the story of the "string of spiders" in a pattern spread to the Qing Dynasty is still in use.

The birth of Zhuang brocade is basically divided into two cultural pattern models. The first one is Dani sister and stronger sister, who takes inspiration and innovates the traditional weaving patterns and patterns, so that Zhuang brocade appeared and developed; the second one has mastered the brocade technology and taught the brocade techniques. The birth of Zhuang brocade was caused by two forces, one is the introduction of brocade technology outside Guangxi; the other is that after the zhuang people mastered brocade technology, the long time process was subtly influenced by customs and customs, and in the innovative practice of many Zhuang women, the brocade was transformed into textiles with Zhuang characteristics. The cultural schema of these two stories is basically in line with the development law of brocade in Guangxi. Guangxi brocade in Song and Yuan Dynasties —— native brocade in Ming and Qing Dynasties —— modern Zhuang brocade. In this process, although the story and plot sometimes evolve due to the influence of time and culture, its social memory core is the basic process of the formation of Zhuang brocade in Guangxi,

(2) Guangxi Zhuang brocade The legend of the fairy

Zhuang brocade From the birth to the nationalization of the Zhuang society, there must be some plots or touching events triggered, and Zhuang brocade is the combination of the material and spiritual needs of the Zhuang people. Zhuang brocade With the fairy story, build the Zhuang people for the pursuit of a happy life, with the crystallization of hard work and wisdom to present the Zhuang people's "happiness code", and the legend of Zhuang brocade and the fairy is the best model for the collision and integration of this event.

As early as 1952, Xiao Ganniu told the story of "A Zhuang brocade" in Huang Yonghe, a farmer from Greenland Village, Chengxiang Town, Laibin County, which was widely circulated in Guangxi. The story is as follows:

In ancient times, there was a flat ground at the foot of the mountain, and there were several huts on the flat ground. In the hut there lived a woman named Dabu. Her husband died, leaving three cubs. He shouted Le Mo, the second Le Dui, and the third Le Zai. Dabu is well Zhuang brocade. The flowers and birds woven on the brocade, fresh. People buy her Zhuang brocade to do strap, quilt, bed felt. A family of four lived on Dabu weaving Zhuang brocade. One day, Dabubu picked up several Zhuang brocade to sell on the fair. I saw a colorful picture in the shop, with tall houses, beautiful gardens, large fields; orchards, vegetable gardens and fishing ponds; and flocks of cattle, sheep, chickens and ducks. She looked and looked, with a happy heart. Originally, I planned to buy rice for all the money I had obtained from selling brocade. But because I love this painting, I bought a little less rice and bought the

painting back home. When she got home, she opened the picture to her sons and said to the big baby, "Le Mo, we had better live in such a village!" Le o curled and said, "Amy, sleep!" Daabu said to the two cubs: "Le dui, we live in such a village!" Le Dui also curled his mouth and said: "Amy, the second world!" Dabu frowned to the three cubs and said: "Le Jia, I must not live in such a village, I will suffocate." With a long sigh. Le thought about it and comforted her mother by saying, "Amy, your brocade is very well woven, and the things on the brocade are fresh. You had better weave this picture on the brocade, and if you look at it, it is just like living in a beautiful village." Dabu thought for a moment, and the nozzle said, "You are right, and I'll do it! Or I would be suffocated." Dabu bought colorful silk thread, set the machine, according to the picture. Day after day, month after month. Le Mo and Le Dui are not satisfied with mother's work, they often open mother's hand and said: "Amy, you do not sell, only rely on us to cut wood for rice, we are too hard." Le ya said to the eldest brother, the second brother: "let Amy knit, mother will not die. You think it is hard to cut wood, so I will cut it alone." The life of the family, by Le Jia every day mountain cutting firewood maintenance.

Dabu worked the brocade day and night and lit the pine at night. The smoke was so heavy that Dababu's eyes were smoked. But Dabb refused to stop. A year later, da Bu's tears dripping on the brocade, she was on the tears woven a clear river, woven a round fishing pond. Two years later, da Bu's eyes were dripping on the brocade, and she had woven the red sun and the bright flowers. Weaving ah weaving, has been woven for three years, this big Zhuang brocade only woven successfully. How beautiful this Zhuang brocade is! A few tall houses, blue tiles, green walls, red pillars, yellow gates. In front of the door was a large garden with bright flowers. There is a fishing pond in the garden, in which the goldfish wagged their tails. On the left side of the house is an orchard, the fruit trees with red fruit, all kinds of birds; on the right side of the house is a vegetable garden, full of green vegetables, yellow melons, and on the side of the house is a large meadow, cattle and sheep cages, cattle and sheep grazing on the grass, chickens and ducks in the grass. Not far from the house, at the foot of the hill, there was a large field, full of golden corn and rice. The clear river flowed in front of the village, and the red sun shone down from the sky. "Tut, tut, this Zhuang brocade is so beautiful!" The three sons marveled. Dabu stretched out her waist, wiped her red eyes, and grinned loudly. Suddenly a gust of wind from the west, "split pop" the Zhuang brocade out of the door, rolled in the sky, has been flying to the east. Dabu hurried out, swinging his hands, and shouted. Ah, turn your eyes and Zhuang brocade disappeared.

Dabu passed out outside the front door. The three brothers helped their mother back and slept in the bed. After filling a bowl of ginger soup, she slowly woke up and said to her eldest son, "Le Mo, go to the East to find a Zhuang brocade. It is Amy's lifeblood!" Le Mo nodded, put on her sandals and walked east.

After a month, she reached the mountain pass. There was a stone house at the mountain pass, and on the right was a big stone horse. Shi horse opened his mouth and wanted to eat the red bayberry fruit on a tree around him. At the door of the house sat an old woman with white hair. When she saw Le passing by, she asked him, "Young, where are you going?" Le Mo said: "I went to find a Zhuang brocade, is my mother woven for three years, was blown east by the wind." The old woman said: "Zhuang brocade is a group of fairies from the Eastern Sun Mountain to go. They see

that your mother's Zhuang brocade is well woven, and they want to take it for show. It's not easy to get to them! First knock your teeth and put them into the mouth of my big horse. Big stone horse has teeth, will move, will eat around the bayberry fruit. It ate ten red bayberry fruit, you step on its back, it will carry you to the sun Mountain. On the way to pass the roaring volcano, the stone horse into the fire, you have to bite the teeth root, can not shout pain, as long as a shout, you will be burned into charcoal. Over the volcano, to the vast ocean, the sea wind and waves are very big, with ice to your body, you have to bite the teeth root endure, can not fight a cold war, as long as a cold war, the waves will bury you under the sea. Cross the vast ocean, you can go to the sun mountain, to the fairy back to your mother's Zhuang brocade."Lemo felt his teeth, thought of the fire, thought of the impact of the waves, and his face was green. The old woman looked at his face, smiled and said, " If you can't afford, don't go! I send you a box of gold, you go home to live a good life!"The old woman took out a small iron box of gold in the stone room and gave it to Le Mo. Le o took the small iron box and walked away. Le Mo walked all the way home, all the way thought: with this small box of gold, my life will be better. Can't take it home ah, four people to enjoy which one to enjoy so comfortable! He decided not to go home, and walked to a big city. Dabu was so thin that he waited in bed for two months and went home without Lime. He to the second son: " Le pile, you go to the east to find Zhuang brocade, that Zhuang brocade is Amy's lifeblood!"He nodded, put on his straw sandals, and walked east.

After a month, he reached the mountain pass. And I met an old woman sitting at the door of the stone house. The old woman said something to him again. Touch his teeth, think of the fire, think of the impact of the waves, his face is green. The old woman also handed in a small iron box of gold to him, he took the small iron box, and the eldest brother thought, refused to go home, walked toward the big city. Dabu was sick in bed and waited for another two months, feeling as thin as a dry wood stick. She looked at the door every day to cry, the original red ba slag eyes, cry ah cry, cry blind, see no brother things.

One day Le Jia said to his mother, " Amy! Big brother two elder brother did not come back, about what happened on the road. Let me go, I must find the Zhuang brocade back."Dabu thought for a moment and said," Get you! Pay attention to your own body all the way!"Le Yong put on his straw sandals, held out his chest, and marched east. It was only half a month to reach the mountain pass. Here I met the old woman sitting in front of the stone house. The old woman still said that words to him, and then said: " Baby, your eldest brother and second brother all take a small box of gold back, you also take a box back!"Le patted his chest and said," No, I'm going to find Zhuang brocade!"He picked up a stone, knocked down his two teeth, and put them in the mouth of the big stone horse. The big stone horse moves, stretched its mouth to eat the bayberry fruit. Seeing it eat ten, Le Zai jumped on the horse to catch the horse's mane and caught a foot, the stone horse raised his head and ran a long hoarse to the east. After three days and three nights, I reached the hair volcano. The red fire rushed at the horse, the fire hot skin squeak, Le get down on the horse, clenched his teeth to endure. It took about half a day to cross the hair volcano and jump into the vast ocean. The waves came over with big ice, cold and painful, and Lejay bent on his horse's back, clenched his teeth and endured. Half a day, ran to the other side, here is the sun mountain, the sun shines on the body of Le ya, warm and,

very comfortable ah! On the top of the sun there is a large golden house, in which floated out the woman's singing and laughter. With his feet, the stone horse jumped into the air and came to the door of the big house. Le jumped off, and headed for the gate, and saw a great crowd of beautiful fairies weaving in the hall; Amy's Zhuang brocade lay in the middle, and they learned to weave. They were surprised when they saw Le breaking in. When she explained the purpose, a fairy said, " Well, we can finish weaving tonight and give it back to you tomorrow morning. Please wait a night here!" Le Jia agreed. At night, the fairies hung a pearl in the hall, the hall is clearly bright. They weave the brocade through the night. There was a fairy in red, the most clever, she knitted first. She compared what she had knitted to what she had knitted, and felt that it was much better. The red fairy said to herself, " I would have lived on this Zhuang brocade." She saw that others had not finished weaving, and conveniently picked up the silk thread on the Zhuang brocade, embroidered with her own image, standing by the fish pond, looking at the bright red flowers.

When Le Ge woke up, it was late at night, and the fairies went back to their room to sleep. In the bright pearl, he saw Amy's Zhuang brocade still placed on the table, he thought: tomorrow if they don't give me Zhuang brocade, how to do Amy disease in bed for a long time, can't delay, I still picked up Zhuang brocade night go! Le Jia stood up, picked up Amy's Zhuang brocade, folded it well, and hid it in his chest. He walked out of the gate and mounted himself and ran away. He leaned on his horse, crossed the vast ocean, crossed the hot mountains, and soon returned to the mountain pass. Le Jay jumped off from his horse. The old woman pulled her teeth out of the horse's mouth and Amle's mouth. The stone horse stood still beside the bayberry tree. The old woman took out a pair of moccasins from the stone house and gave them to Le ya and said: " Dear b, wear moccasins and go back, Amy is going to die!"

Le Le wore moccasins, turned his eyes and arrived home. He saw Amy sleeping in bed, thin as a dry wood, humming weakly, really about to die. Le Ge went to the bed, shouted "Amy", took out the Zhuang brocade from the chest, in front of Amy, dazzling, Amy's eyes bright. She crawled up and smiled at the Zhuang brocade she had knitted for three years. She said, " Cub, the hut is dark. Let's take it outside the gate and look in the sun." The two went to the door and spread the Zhuang brocade on the ground. A sweet wind blew, and Zhuang brocade slowly stretched out, covering the flat land several miles wide. The hut where Dabu lived had disappeared, but there were some magnificent houses, surrounded by gardens, gardens, fields, cattle and sheep, exactly like those woven on brocade. Dab and Leya stood at the big door. Suddenly, Dabu saw a girl in red by the fish pond in the garden looking at the flowers. Dabu hurried over and asked. The girl said she was a fairy, because her image was embroidered on Zhuang brocade. Dabu invited the fairy into the house and stayed together. Le Jia had married the beautiful girl and lived a happy life. Dabu invited people from nearby to live in the village. One day, two beggars came to the village, they are Le Mo and Le Dui. They got the old woman's gold and went to the city to live, eating and drinking. Soon, the gold ran out, and they had to beg for food. They came to this beautiful village and saw Amy and Leya singing happily in the garden. Recalling the past, they went in, dragged their begging staff and walked away (Guo, 2001, P: 408-411) (Figure 12).



Figure 13 A cartoon poster for "Zhuang brocade"
Source : <https://movie.douban.com> 17/January/2024

The story of "a Zhuang brocade" describes the whole process of "Zhuang women dabu brocade — innovation Zhuang brocade — lost Zhuang brocade — difficult test to find Zhuang brocade — to find Zhuang brocade — happy life". First, it affirmed the innovation process of weaving Zhuang brocade exploration; second, the result of the test of the three sons seeking Zhuang brocade, and affirmed the tenacity, courage and fighting character; finally, the happy life after Zhuang brocade. The whole story has many symbolic meanings, one is the parents for the son brocade, for Zhuang brocade become the zhuang wedding necessary dowry buried solid seeds; the second is the son through the brocade, is also the zhuang important life etiquette rite test link; the third of the Zhuang brocade weaving is the parents express the good hope for their children's happy life.

In brocadexi, there is also a "fairy and Zhuang brocade" legend: once upon a time, there was a Zhuang girl whose father died early, her mother was old and could not work, and the girl was twenty years old and she was not married, so she relied on her labor to support her mother. Her family was poor and had no land. The girl went up to the mountain every day to cut firewood to sell it in the street and buy some grains to live at home. One day, the sky of the seven flowers to play, in the heavy rain hiding in a roadside cave, I saw a girl carrying firewood, walking in the rain, through the mouth of the cave, seven flowers busy called her to the hole to shelter from the rain, when the rain is fine, mother said, she was eager to send firewood to the rich home, or the mother will be hungry at home. Seven flower fairy then asked the girl's life to know that her mother and daughter lonely, life is difficult. The flower fairies were moved by the girl filial mother heart, the youngest flower fairy seven sister decided to help her, then god went to steal the shuttle down, she said to the girl: " I teach you the technology of brocade, you weave brocade to the street to sell, you can live. The girl was clever and quickly learned to weave brocade, she knitted very well, got to the street, people rushed to buy. The girl had never been married in order to support her mother. Flower fairy seven younger sister back to heaven, the girl miss

her, then respect her for the flower god. According to legend, only the flower god can weave a good brocade, so the women of the brocade all respect the flower god and are all pure and clean (Bao, 1987, P: 135-138).

In addition, in the Zhuang areas of Xiangzhou and Laibin, there is a story of Zhuang brocade directly related to the belief of the flower goddess: a Zhuang girl named Zhang Dahuan, with 10 sisters, 9 of whom are married, leaving her alone in her boudoir. Because her mother asserted that she killed Rikko, no one dared to marry her. However, Zhang Dahuan did not believe in fate, and worked hard to learn the skills of brocade, her brocade silk was particularly beautiful, attracted people praise. A young man was moved by her exquisite brocade skills, the heart of love after the song to her love, two people then agreed for life. Later, Zhang Dahuan was framed by his sister, said that he did not know the prosecution, his mother did not ask why, responsibility to hit the ring, the ring humiliation and commit suicide. Dahuan knew that many husband and wife after marriage, leading to incompatible husband and wife, the heart is willing to send children to them, legend that three days after the earth, the grave grow moving flowers, Buddha named her as the flower king, dedicated to people to send children. Therefore, when the Zhuang family gives birth to the first child, they usually worship the goddess at the bed (Editorial Group of Guangxi Zhuang Autonomous Region, 1984, P: 282).

The story of "Zhuang brocade and fairy" in brocadexi and Xiangzhou and Laibin combines the fairy with the folk belief of the Zhuang nationality, the flower god (the god of the flower woman), forming a model of the integration of Zhuang brocade and faith. brocadexi is moved to help the Zhuang girl teach the art of brocade. At the end of the story, the story combines the fairy with the belief of the Zhuang flower god. Xiangzhou, guests from the lover of the feudal superstition persecution, the construction of the flower goddess belief to build, the ring was sealed as the Buddha of the flower king, to people to send children. Integrating Zhuang brocade into the belief system of Zhuang people makes Zhuang brocade more harmoniously integrated into the life of Zhuang people, and becomes the driving force for Zhuang brocade to be inherited in Guangxi for thousands of years.

(3) Guangxi Zhuang brocade and chieftain legend

During the Ming and Qing Dynasties, Guangxi mainly adopted chiefess governance. In order to complete the task of tugong, while supporting the development of Zhuang brocade on the whole, the governance of chieftain also maintained repression and exploitation on the Zhuang people. Zhuang brocade The predecessor of the earth brocade, Has been formed during the Ming and Qing Dynasties, With the development of Zhuang brocade and the intensified contradiction between chieftain governance, Tugong Zhuang brocade became the key topic of discussion, Then came the story of "Moman invention brocade", "Bao Sang and QiaoNi", "Dawang" and "Motu Guan Zhuang brocade", These stories, in the process of Zhuang brocade nationalization, Form the cultural schema of "superb brocade artist —— local official exploitation —— brocade artist's inability to resist —— leaving a beautiful legend".

First, the process of Mormaan's invention of the brocade is basically similar, but the two stories end slightly differently."According to legend, in ancient times, there was a beautiful girl named Moman in Banhe Village, Xincheng,The news of being able to weave colored cloth soon spread in the local area, and the neighborhood

girls came to learn from her. Since then, more and more colorful soil brocade into the market, into people's life. Later, because the local official master to send the beautiful Moran to the court as a maid, Moran vowed to die, hide to the cave in front of the village, into a stone. There is a cave called Moran Rock in front of Cheng Tun Village, Banhe Village, Chengguan Town, which is the evidence of Moran's invention of Zhuang brocade (Lan, 2019)."Second," Moran lived in Xincheng Tusi Moru ruling period, was born in Xincheng County Banhe Village Committee Tun, birth and death date unknown..... Moran is young and beautiful, in addition to mastering exquisite brocade skills, singing folk songs is also particularly good. So, there are some ulterior motives to catch Man sent into the palace, dedicated to the emperor. Moran is not from, was pursued by bad people, and lover fled to a cave near the county to live. Later, he found Mormaan. On the edge of the cliff, Moman and lover fought with evil people, the results of both killed. In order to commemorate Moran, later generations called the cave "Moran Rock", which is still used today (Figure 13).



Figure 14 Moman Square, Banhe Village
Source : <https://mp.weixin.qq.com/s/17/January/2024>

Secondly, Bao Sang and Qiao Ni Zhuang folklore. Description of a young man named Bao Sang is good at painting, his wife Qiao Ni is good at weaving brocade, their paintings and woven brocade lifelike. Once, the painting and the people, cattle and sheep came out to help them work. This miracle was known by the local county officials, so they forcibly took Bao Sang and Qiao Ni all the paintings and brocade robbed. The magistrate got the things and went home and opened them. The paintings and brocade became white pictures with nothing on them, while the original paintings and the figures on the brocade all flew up to the rock wall of Anshan. The county officials forced their couple to draw 99 gold and silver treasures, weaving 99 fertile fields of 100 mu of Zhuang brocade. Bao Sang and Qiao Ni do not agree, were burned alive by the county magistrate. But their portraits also flew to the rock wall of Anshan, and lived as forever on the rock wall as their paintings and the patterns on the brocade (Liao & Lu, 2012, P: 4).

Again, the Dawang Zhuang folklore. Legend has it that there is a girl named Dawang, once she woven a flower Zhuang brocade, the Zhuang brocade by bright colors, lit up half the sky, disturbed the butterfly flying set around the brocade. After this matter spread, but to da wang brought the evil — chieftain master to marry her as a concubine. Dawang did not agree, the chieftain master made the trick to kill Dawang. On the day Dawang was killed, her body was hung in a cave, and birds came to hang piety, wake, and jiao; magpies came to be Taoist; cough birds came to be drummer. They spent three days and three nights eating it out before burying Dawang's body into the moon (Liao & Lu, 2012, P: 6).

Thirdly, in 1957, Qin Jiancai told the story through Qin brocadeglan, Jiaguang Village, Pingguo County, and the story is as follows: In ancient times, there was a clever and strong girl named Dawang, the daughter of a farming family, blushing as red as a peach blossom, and her eyes as beautiful as a spring stream. She does a good hand of sewing, knitting Zhuang brocade is really unparalleled in the world. Once, she woven a flower Zhuang brocade, hanging in front of the dripping eaves. Bright patterns shine, lit up half of the sky, disturbed the butterfly, flying set around the brocade quilt, half a day also reluctant to leave. The matter soon spread, and everyone knew that Dawang was an expert at brocade. Dawang became famous but brought disaster. Chieftain ye did everything possible to marry her, sent the official media to her home to say several times. Dawang scolded the matchmaker and never dare to come again. Chiefess vowed to marry da wang hand, marry not also want to kill her to be willing. It happened that year drought, a drop of rain, the seedlings are about to dry coke. Tusi along the old example, kill frogs to sacrifice thunder gong for rain. In ancient times, the Zhuang people had the habit of killing frogs to sacrifice the thunder men and making the men for three days and three nights to worship, while the zhai men did not eat for three days, or the thunder men blamed the people for not being sincere and refused to rain. On July 16 of that year, the chieftain killed the frog and made an open doway near his home. He was determined to defeat him and sent her to hold a fast. Tusi and da wang told sure: to her three days and three nights do not eat, every day in the sacrificial table worship thunder. The first day passed, and the second day also passed, to the third evening, the chieftain asked someone to check the wang fasting scene, and said that she did not import water. Tusi thought of a poison meter, called people quietly to the sacrificial table to steal a bowl of glutinous rice. On the fourth day, the toast personally went to the sacrificial table to check the offerings, and falsely said in public that the lost bowl of glutinous rice was eaten by Dawang. If he did not admit it, he cut open her stomach for inspection. He secretly sent someone to Dawang and said, " You promise to marry your master, you can forgive your sin. Otherwise, you would be dead." King heart hard over iron, said: " I am not guilty, don't master pardon. My master wanted to marry me unless there was not the grass and the sun. I am not afraid of death, I am willing to open my intestines to see, so that the world know that the wicked framed me. I'm innocent." The bearer reported Dawang's words to the toast. Chieftain angry face blue veins all protruding, ordered immediately to reach wang belly. When the villagers heard that the chieftain was going to kill Dawang, they all came to watch him. Her companions and sisters partnership to chieftain to petition, asking chieftain to pardon his death. The toast ordered the executioner to cut it quickly. The executioner killed Dawang, cut out his intestines to cut open a look, inside empty, no glutinous rice. Knowing that Dawang had been

wronged, they burst into tears. Suddenly the sky was dark and the wind was stormy. The wind and rain stopped, and there was no sign of Dawang's body. The original body of Dawang's was blown into a mountain cave. All birds to hang filial piety, wake, jiao. Red butt birds do teacher, magpie do Taoist, cough birds do drummer, crow, white head weng and so on to hang filial piety. They spent three days and three night festivals, and carried Dawang's body into the moon for burial. From then on, every year on Frost's descent, all the birds worship the grave, so that day even the shadow of the birds is missing. People, July 20, the death day of wang, every family kill chickens and ducks to her, but also the chicken legs to the moon out, just let the children in the moonlight while listening to the story while eating (Guo, 2001, P: 764-765).

Finally, in the struggle between the Zhuang brocade artists and the local officials, it reflects the spirit of the Zhuang people in spite of oppression. At the same time, the brocade of the Zhuang nationality has become an important productivity in ordinary families, and also enhances the family status of the Zhuang women. The story ends with a happy ending, symbolizing the good wishes of the Zhuang women to pursue a happy life. In addition, while suppressing the Zhuang people, they, in order to protect the official women, established that the official women were not allowed to participate in the brocade. Such as "Mo tu official offer brocade" story widely spread in Xincheng area. Soil brocade was first used among the local people, and was later attracted by the chieftain as a tribute to the emperor. Legend of the emperor saw the brocade also very appreciated, once sent an official for treasures to the emperor, to xincheng tu county, life mo tu officer offer one hundred soil brocade, mo tu officer appointed, immediately concentrated XinCheng soil brocade expert drive tribute for him, it is said that is afraid of the emperor love brocade and the brocade girl called to Beibrocadeg, rules all soil officials of women are not allowed to attend soil brocade, so official women will not brocade. In addition, according to Xincheng County Zhuang brocade club more than 70 years old worker Huang Aiqin said, in her more than ten years old, the chieftain official Mo Song's wife Pan (Mo 2 too), because the woman of the family can not brocade, especially asked Huang Aiqin's mother to help brocade (Qing, 1990, P: 162).

Zhuang brocade The legends of Tusi is basically the legends and stories produced under the administration of Tusi in Guangxi in the Ming and Qing Dynasties. Its content is often combined with the ethnic customs and local living habits of Guangxi at that time to enhance the credibility and transmission of the stories, and strengthen the characteristics of the Zhuang nationality and local characteristics in the artistic style.

(4) Learning the legend of Guangxi Zhuang brocade

Zhuang brocade In the process of inheritance, although give Zhuang brocade a variety of moral and beautiful yearning, but in the professor Zhuang brocade, skills and patterns also Zhuang brocade one of the origin, Yan Sihui in the "return to Zhili state" custom volume three, wrote: "not ji daughter is to learn to weave." It shows that Zhuang girls began to learn brocade techniques when they were minors, and in the process of teaching brocade skills, they formed important educational stories. According to the folklore of the Zhuang people, "There is a Zhuang girl who wants to learn the secret of brocade. The old woman asked her to weave a new peacock brocade pattern before telling her the secret. Harry was devoted to studying, getting

up early and going to bed late, working hard to weave brocade, and tired without rest. He was busy for three days to weave this peacock brocade. The old woman smiled and told her: the secret is to study hard. After Harry understood, he had been studying hard and finally became a famous local brocade expert (Liao & Lu, 2012, P: 38). "Zhuang women usually encourage zhuang girls to brave difficulties, study hard and practice hard, and become brocade experts. The secret of Zhuang brocade stretching for thousands of years is the silent education of Zhuang women from generation to generation, and the orderly inheritance of cultural knowledge and social memory in the process of Zhuang society.

Part II: Guangxi Zhuang brocade, The social memory of Chinese totem and faith

In the case of low productivity, the ancestors of the Zhuang people were often threatened by nature and unable to resist. People turned to produce spiritual worship on the things and things that had a profound influence, which was the totem and belief constructed by the ancestors of the early Zhuang people. Totems and faith are the deep study of the relationship between human beings and nature, which are used to explain the emergence, development and extinction of all things in the world. These totems and faith symbols pass through time and are activated through Zhuang brocade patterns. The pattern of Zhuang brocade contains many totem worship and the symbolic meaning of primitive beliefs. Zhuang brocade In the process of nationalization, the Zhuang culture, religious belief and the state of living space are integrated into the Zhuang brocade invention and creation process, and totem and belief pattern play an important role of Zhuang cultural symbols in Zhuang brocade, becoming an important form of inheritance and activation of Zhuang social memory. Zhuang brocade As the carrier of social memory, it is the social memory of how to inherit totem and belief through patterns.

2.1 Guangxi Zhuang brocade totem in Guangxi Zhuang brocade

It is unclear when the ancestors of the totem worship of the Zhuang nationality has distinct characteristics. They believed that the totem object of the worship is the personified god and has a kinship relationship with themselves. Influenced by the original religion, the ancestors of the Zhuang nationality still retained the totem worship. Due to the differences of the tribes or clans of the ancestors, the totem worship has the characteristics of diversification and variation. The totem worship is mainly widely circulated in folk myths and legends and a small number of literature records. Flower totem, dragon and snake totem, bird totem, frog totem, cow totem and dog totem are the best that of national culture and national belief worship in Zhuang brocade. The following analysis studies the social memory of totem patterns associated with Zhuang brocade patterns.

(1) Flower totem

The flower pattern in Zhuang brocade, as one of its core elements, is highly representative. Through field interviews, we had in-depth exchanges between brocade artists and Zhuang brocade users in brocadexi area, and learned that these colorful "flower" patterns are closely linked to the worship of flower totem of the Zhuang nationality, and this worship is directly related to the belief of "flower woman". In the belief system of the Zhuang nationality, the flower woman is honored as the "Virgin of the Flower King". She is in charge of human reproduction and the important responsibility of giving flowers and children. In addition, according to legend, the image of Hua woman comes from the first grandmother of the Zhuang nationality,

"mother sixty jia". She was born in blooming flowers on the second day of the second lunar month, so she is honored as "flower woman Goddess", and is widely worshipped and respected in the Zhuang people (Figure 14). Every year on the third day of March, one of the gathering places of the Zhuang nationality, and some areas celebrate the 12th, 25th and 29th day of the second lunar month. In the village, women of the same generation became sisters of the opposite sex, pooled together to prepare chicken and duck and incense paper for the flower goddess, and then gathered flowers in the wild to pray for birth and bless the healthy growth of children (Wu, 2022, P: 65-66).



Figure 15 The brocadegxi Zhuang people worship the "flower woman god" tablet
Source: Yaocheng Tian was photographed at He Gao's home in Run Town,
brocadeghu Lake 17 / April / 2023

The Zhuang area has a direct connection with all aspects of the Zhuang life through the customs of worshipping the flower woman and establishing the position of the goddess. For example, "in ancient times, when strong people get married, they should install a flower woman god card in the bridal chamber, which is the symbol of the flower woman. Flower woman god is the god of marriage, the special management of children, and is the patron saint of children. According to the folklore of the Zhuang nationality, all children born, both men and women, are flowers planted by the goddess and will be protected by the god" (Chen, 2008, P: 113-114). Another example of Liu Xifan of the Republic of China "Ling Biao Ji Man" wrote, the lack of Zhuang children, and many children are sick, in order to pray for the strong children and health, will ask the wizard to pray for the goddess (Liao, 2002, P: 270).

Zhuang brocade In the process of nationalization, the important integration into the Zhuang society is that Zhuang brocade the flower pattern and the flower woman belief are closely linked to build a good meaning. For example, the small white flowers and small red flowers that often appear in Zhuang brocade are often used on the strap or quilt surface. These patterns have a direct relationship with the worship of flower totem. If she sent red flowers to who, who will give birth to a girl,

send white flowers to who, who will give birth to a boy (Ma, 2007, P: 122-123). Zhuang brocade The white round dot flowers that often appear on it are related to the flower totem worship of the Zhuang nationality. The Zhuang brocade pattern remains the ancient totem worship, which is the image reflection of the inheritance of the totem worship consciousness in the national culture. Another example is the li Tiaoyuan's "South Yue Notes" in the Qing Dynasty of "white flower male, red flower female" (Liao, 2002, P: 270). Therefore, the flower pattern in Zhuang brocade is considered to be due to the belief of the flower women (Figure 15).



Figure 16 Diamond chrysanthemum lines Zhuang brocade strap heart

Source: Photo taken by Yaocheng Tian at brocadegxi Zhuang Museum 17 / April / 2023

(2) Dragon snake totem

The natural environment of subtropical Guangxi is very suitable for the survival of insects, but the ancestors of the Zhuang people were often attacked by worms. At the end of the primitive society, the Zhuang people, seeking powerful animals, used snakes, crocodiles and dragon as totem symbols, and thus produced the worship of "dragon and snake totem".

The Zhuang ancestors of the ancient Yue people have many branches of the snake as a totem. Han Xu Shen said in "Bu", "Nanman, snake species." And: "Fujian, southeast Yue, snake species also." The so-called "snake species" is the ancestor of snakes. The custom of the worship of snake totem still existed in the Lingnan area of the Qing Dynasty. In the early Qing Dynasty, Gu Yanwu quoted the Chaozhou Annals in the Book of National Diseases, The Counties of the World: "With the South Man as the snake species, we can see the Tanka gods." Dong Xi Qian Annals also said: "People are snakes, so sacrifices to the snake god." In addition, there is a similar story in the Daming Mountain area of Guangxi: a lonely old mother adopted a short tail snake (Zhuang language is "special excavation", meaning "short tail man"). On the day of her death, a gust of wind escorted the old man's body to the back hill cave for burial, and then it brought the dragon to heaven. Every year around March 3, when the wind blows and it pours, the old people say: "Special dig back to sweep the grave!" People felt the kindness of the old mother (mother of Dragon) and the filial piety, built the mother of Dragon Temple and made five-color glutinous rice to

worship the mother of Dragon and special excavation (Wu, 2022, P: 73-82). From this story, we can see that the Zhuang ancestors believed that snakes could be transformed into dragons. In Zhuang brocade, the hexagonal python dragon pattern composed of a special meaning is actually the symbol of the Zhuang dragon (snake) totem (Huang & Ye, 1988, P: 14-22) (Figure 16).



Figure 17 Python dragon pattern Zhuang brocade large wall hanging
Source: Photo taken by Yaocheng Tian in Nanning Intangible Cultural Heritage Life Center 9 / November / 2023

(3) Bird totem

Bird totem is one of the totems widely spread in Baiyue region. Some Zhuang ancestors took birds as the totem of their tribes in ancient times, due to the geographical and cultural differences between different tribes and clans of the Zhuang ancestors, resulting in the diversity of bird totem of the Zhuang nationality. Professor Qin Xiaohang from the Institute of Chinese Minority Languages believes that "The Holy Mother of the Six Wu" is the prototype of the worship of the Zhuang bird god (Qin, 1993, P: 79-83).

There are still many myths and legends and stories about bird totem worship in Guangxi, among which the most widely spread legend is "One Hundred Birds' Clothing". One day, on the way home to gather firewood, a big hen jumped into his empty basket to go home with him. Mother said that it is not their own things can not want, Zhang Yayuan sent the hen back to the village, but in the evening the hen came back again, for several days, Zhang Yayuan had to stay to feed. Half a year later, the chicken turned into a beautiful girl to repay her kindness and married him. After marriage, the husband and wife love, opened a shop, the door posted a "big official department store without, Xiaoya original meet goods" couplet. A top scholar saw the couplet after their husband and wife, but did not trouble them. After the top scholar saw Zhang Yayuan's wife smart and capable, then strong robbed to the emperor. Before leaving, his wife told Yayuan to go to the forest to beat a hundred birds to make a feather suit, and then beat the drums to find her. Three years later, Yayuan finally knitted the bird suit and arrived in the capital. The emperor saw the original wife usually sad, but saw the original dance feather can laugh, to win her favor, the emperor took off the dragon robe, put on the feather dance up. His wife immediately called for someone to kill the emperor. Then Zhang Yayuan and his wife both fled the

palace, rode a fast horse, and lived a wonderful life (Liao, & Lu, 2012, P: 37). The ancestors of the Zhuang people used the feathers of birds as gods, which were basically similar to the "kingdom of the people" and "the people" recorded in the Classic of Mountains and Seas and Huainan Zi, and evolved into the legend of Hundred Birds.

The totem patterns of Zhuang birds mainly include egrets, phoenix, chicken, swallow and other patterns, which constitute the rich "bird patterns" patterns in Zhuang brocade. Among them, chicken and chicken are the most totem significance in the Zhuang nationality. Phoenix bird pattern phoenix pattern is used frequently in the Zhuang brocade, as the folk saying goes, " Ten pieces Zhuang brocade nine phoenix, live like phoenix from the brocade."In Zhuang brocade, the phoenix bird pattern absorbs some of the characteristics of peacock, brocade rooster and rooster, and constructs the ideal phoenix pattern pattern, where the noble and auspicious of the peacock, the beauty of the brocade rooster, and the moral character of the rooster are contained in the phoenix pattern (Figure 17).



Figure 18 Dragon and phoenix kirin deer chicken pattern Zhuang brocade quilt face core

Source: Illustration of Zhuang brocade 17 / April / 2023

Chicken lines in Zhuang brocade used more patterns, Zhuang ancestors also have a special liking for chicken, for example, now Guangxi is also widely spread "chicken bu", such as "Ji Ji" Xiao Wu "cloud:" is to both the destruction of South Yue, more people brave is said: 'more people believe in ghosts, and its temple are all ghosts, the number of effective. In the past, the king worship ghost, longevity to 60 years old. Later generations are lazy, so they decay.'Is the more wu stand more wish temple, tai no altar, also the temple god god hundred ghosts, and to chicken divination. On the letter, yan (Si, 1975, P: 487)."Kuang Lu of the Ming Dynasty" Chi Ya "also said:" there is a temple prayer, make the temple god, sacrifice the ghosts, with chicken divination (Kuang, 1935, P: 52)."Chicken is not only homophonic with "ji ", auspicious and auspicious, playing the role of the protector in the life of the

ancestors of the Zhuang people. In the period of the Republic of China, the "dragon and phoenix kirin deer and chicken pattern Zhuang brocade" was popular in the Huanjiang area of Guangxi, with dragon pattern, phoenix pattern, kylin pattern, deer pattern, chicken pattern, pattern and other patterns, the main pattern of the double dragon play flower basket pattern symbolizes female genitalia, the lower part of male genitalia, with a strong reproductive intention to worship. Dragon, phoenix, unicorn, deer and chicken patterns also contain good luck and longevity, which should be used for marriage (Wu & Cai, 2018, P: 184). Therefore, the chicken pattern in Zhuang brocade, the phoenix pattern, unicorn and deer, form an auspicious pattern to express the strong people's desire to pursue a happy and better life.

(4) Frog totem

The Zhuang people called the frog Mafengai. In a settlement or clan of the Zhuang ancestors, the frog was once regarded as a symbol of multiple blessings, so the frog totem has the double implication of totem worship and reproduction worship, and the frog totem also implied a symbol of good weather (Figure 18). In this way, the ceremony of worshiping frog totem evolved into the "Frog Festival", also called "Lap Festival", which is a festival of offering frogs. In Bama, Donglan, Fengshan, Tiane and other Zhuang folk areas, most of the magical story of the frog god, one of which is translated into Chinese lyrics, the general idea: " Frog frog is quack, small and ambitious; patrol day and night in the field, hard to catch insects and protect crops. Frogs and frogs from the world, the gods sent to help the farmers; who dare to offend it easily, thunder called him to blossom his head (Li, 1985)."The frog Festival will be held during the Spring Festival. First, frogs have strong reproductive ability; second, the ancestors of the Zhuang people believe that the call of frogs attracts rain and moistens all things; third, frogs can hunt pests and protect crops. In addition, the fairy story of Frog Fairy is still circulating in Baise Longlin Zhuang region of Guangxi.

Decoration with frogs is a unique frog totem culture of the southern minorities. The frog pattern not only exists in Zhuang brocade, but also shows in other places. The main image of the Zuojiang Huashan Rock mural in Guangxi is the combination of the frog and the man, and the patterns and sculptures on the bronze drum of the Zhuang nationality all have the frog image, which shows that the frog pattern embodies the ethnic culture and folk customs of the Zhuang nationality and is the ethnic symbol of the Zhuang nationality.



Figure 1: Frog pattern Zhuang brocade

Source: Photo taken by Xiaocheng Tian in brocadegxi brocadeyuan 17 / April / 2023

(5) Bull totem

The ancestors of the Zhuang nationality had popular cattle totem worship, and the tribe with cattle as the totem appeared. The ancestors of the Zhuang people first worshipped the yellow cattle and water buffalo (Chen, 1998, P: 32-37). The Wei surnames of the Zhuang nationality (buffalo as the totem) and Mo surnames (cattle as the totem) are all great surnames, and there is a king of Mo as the great god. With the development of rice cultivation of the Zhuang people, the Zhuang people have turned into a custom of worship and love. The Zhuang people living in the mountainous areas of northwest Guangxi have the custom of the Bull Soul Festival on the eighth day of the first April or the sixth day of June of the lunar calendar. Legend has it that this day is the birthday of the cattle king, and some also say that the spring ploughing was over at this time. The Zhuang people are very grateful for the credit of the cattle in the busy spring ploughing, so they specially comfort the festival formed by ploughing the cattle. On this day, not only let the cattle all rest, but also for special careful care. Early in the morning, the children put the cattle out of the barn, led it to the green hills or the field to graze, never to scold the cattle, let them eat grass freely. Adults will repair the cowshed, remove the column of manure and sprinkle with lime, do clean and dry. Some are specialized to cut fresh grass, sprinkle salt water to raise cattle, some also put some eggs and five-color glutinous rice to feed the cattle to eat, some also use a comb to remove cattle lice, with camellia oil daub wounds, etc., in short, is careful care, so that the cattle as soon as possible to recover, maintain a strong body, to meet the arrival of summer harvest summer farming. On this day, people also killed chickens and ducks, made sweet wine and boiled five-color rice, and drank the family to celebrate the annual "cow Soul Festival", to pray for the prosperity of the cattle, the harvest and good years (Mo, 1974, P: 288). Another example is Liao Mingjun described brocadegxi Tang Tong Village The reverence for cattle is mainly reflected in the morning of the Chinese New Year, we will seal all the farm tools used in the field, hang big zongzi and pork in the cattle stall, sprinkle grain in the cow trough, feed the most fresh and tender grass, and not to thank it for its hard work for a year (Li, 2014, P; 90-97). brocadegxi Zhuang brocade factory scroll wall hanging "cow soul", vividly show the Zhuang ancestors in the 'cow soul festival' to the cattle respectfully, the cattle as a guest scene (Figure 19).





Figure 19 Zhuang brocade scroll wall hanging

Source: Photo taken by Xiaocheng Tian in brocadexi Zhuang brocade Factory 17 / April / 2023

(6) Dog totem

As one of the earliest domesticated animals of primitive humans, the dog has its own sensitive sense of smell, sensitive response and running ability, often as a partner of human hunting. The ancestors of the Zhuang people gave mysterious attributes to dogs, such as stone dogs standing in front of the house to ward off evil spirits, while stone dogs widely exist in the southwest of Guangxi, the northwest of Guangxi and the areas where the Zhuang people live in Guizhong. Therefore, the ancestors of the Zhuang people worshipped the dog totem, and made the symbol totem of the tribe or clan, which has been passed down to this day.

First of all, the dog totem is combined with the myth and poetry history of the Zhuang nationality. In the Poems of Blotuo Sutra and Making Man (I), the immortal Bultuo flew to the world to make decisions and carry out the activities of creating people. He made a seal to order, first put down the chicken, second down the dog, the seventh put (down. How important he saw the dogs as dogs! Among the Zhuang people, there is a myth that his grandmother is a noble princess and his grandfather is a heroic dog. Secondly, the Zhuang dog totem has a lofty status. For example, in the rock paintings on the Zuojiang cliff painted by the Luo people, the dog image is often located in the center of the picture, and the form is vigorous. People cheered around them, which vividly reflects the lofty status of the dog in people's minds. At the same

time, in the myth and legend of dogs among the Zhuang people, " In ancient times, there was a nine-tailed dog, fearless of difficulties and risking his life to bring back valley seeds to people from heaven. From then on, people will grow rice. People do not forget the merits of their dogs, so every year when harvesting the new grain in the sixth lunar month, they cook the new rice and feed it to the dogs first (Zhang, 1997, P: 236-237)."

Another example is the Zhuang villages in brocadegxi and Chongzuo County, Guangxi, where people spend the Spring Festival, turning grass into dogs (small dogs), put on colorful clothes, and children travel from village to village to exorcise evil spirits and fight the epidemic and protect peace. To the home, will give to zongzi or meat, thanks to the dog spirit. To express the Zhuang people's lofty respect for dogs. Finally, the dog totem in the hearts of the Zhuang people has "dispel evil town demon" and "guard the village", people put the stone dog either at the entrance of the village, or located on both sides of the door, or on the so-called dangerous feng shui land of the broken cliff and dangerous mountain. For example, in the village of the Zhuang nationality near Laibin County, Guangxi Province, there is a statue of a dog's head, with its kiss protruding forward and his eyes open, with a posture ready to deal with all attacks. The local people called the dog head "a grandpa", which means "grandpa". They serve the Spring Festival, the second day of the second lunar month, July 14, August 15, and the sick villagers with cattle heads. Obviously, the Zhuang people regard the dog as the ancestor of their "blood relationship", that is, the dog as their own totem. Zhuang brocade The dog pattern is mainly widely used in the Hengarea, using the strap core, meaning protection and strong growth (Figure 20).



Figure 20 Dog totem Zhuang brocade strap heart

Source: Yaocheng Tian was photographed at Wei Fengxian's home in HengCity 17 / April / 2023

2.2 for the social memory of the original belief in the Guangxi Zhuang brocade

In the original religious beliefs of the Zhuang people, we can also find traces of totem worship. Folk belief mainly refers to the beliefs and customs related to the worship concepts, behaviors, taboos, rituals and rituals of gods, also known as belief folk custom, which is consciously formed by the general public in the long-term historical development. Zhuang brocade is a traditional folk skill, its graphic pattern and folk social consciousness has a relatively close connection. It can be said that the traditional folk belief is the source of Zhuang brocade pattern, pattern is the embodiment of belief. In ancient times, human productivity level, cognitive ability is relatively low, people in hunger and cold, disease, death and in the natural environment change and panic, to seek the continuation of race, the fear and the pursuit of life, reproduction on the power of the outside world, the deification, thus formed a belief, and with the help of ritual, symbols, etc. Longzhou Zhuang brocade "water ripple" "bird" "pattern" pattern "" sun " pattern, to some extent show the ancestors here with nature activities, often faced with natural change, the threat of life and cannot solve the fear, and must look for outside the supernatural power (god), to seek detachment. The ancestors of Longzhou Zhuang people integrated the unique artistic expression techniques and the combination of patterns into the traditional brocade techniques, functionalized and artistic, so as to express their desire and yearning for life and life, and also endowed these patterns with special beliefs and symbolic implications. Specifically, its purposes are:

(1) sun-worship

The sun pattern, also known as octagonal pattern in Zhuang brocade, originated from the worship of the sun by Zhuang ancestors (Figure 21). The bronze drums used by the ancestors of Xi'ou, Luo Yue and Li Liao are also strong evidence of the worship of the sun totem (Wu, 2022, P: 73-82). The Zhuang folk myths and legends such as "Tekang Shooting the Sun" and "Waiting for the Sun", the sun awn grain on the bronze drum and the sacrificial dance images on the Zuojiang Rock mural in Guangxi reflect the worship of the sun by the ancient Zhuang ancestors from various aspects. Zhuang women weave the "sun pattern" into Zhuang brocade to make clothes, headdresses, quilt faces and baby braces, to pray for the sun god to bless the family, auspicious happiness and healthy growth. In addition, some people believe that all the circle patterns in the brocade are the remains of the totem of the sun, which shows that the ancient Zhuang ancestors worship the sun god lasted for a long time. The Zhuang people believe that the 13th day of the second lunar month is the birthday of the sun, and a warm and grand festival activities should be held. The place of worship, mostly in the open area near the village, or can see the sunrise and sunset on the mountains. The sacrificial ceremony was presided over by the patriarch to kill a white rooster, a red rooster and a pig. The sacrifice is placed under the tree, including a bowl of blood and a branch, and not reciting the sacrifice. After the sacrifice, the adult men ate a single meal on the sacrificial floor (Lan & Wang, 1990, P: 759). The sun pattern is the embodiment of the ancestors of the Zhuang people thinking about heaven and earth and the primitive life, and is the image expression form praying for the protection of the sun god. The patterns in Zhuang brocade, whether geometric or figurative, are vivid and exquisite, with rich changes and great connotation. These abstract, concrete patterns are extremely decorative and are essential components of

Zhuang brocade. They are the highly aesthetic products created by the ancestors of the Zhuang people after highly summarizing the nature of flowers, birds, grass and insects. They are the artistic images produced by ethnic beliefs, ethnic culture, folk customs and reproductive worship. They are the visual carriers of the Zhuang people's reverence for life and good wishes (Zhang, 2013, P: 51-53).



Figure 21 Sun grain Zhuang brocade back belt heart
Source: Yaocheng Tian shot in field Survey 17 / April / 2023

(2) Tree god worship

Trees are also one of the objects of worship by the Zhuang ancestors. The trees that people worship are mostly towering trees with exuberant vitality, luxuriant leaves and evergreen trees, such as banyan trees, camphor trees, kapok trees, maple trees and so on. People often use trees as people, thinking that these outstanding trees are the houses of god, so they remain evergreen and pray for the shade of the tree god. Folklore camphor wood is the sky tree, the ancient times when heaven and earth is it on the roof, in the village of the middle of the trees, no one dare not cut down the trees, or will cause disaster; people in some places, to send camphor tree custom, these are the ancient tree worship (Figure 22) (Zhang, 1997, P: 227).

พหุ ม ประ โท ชี เว

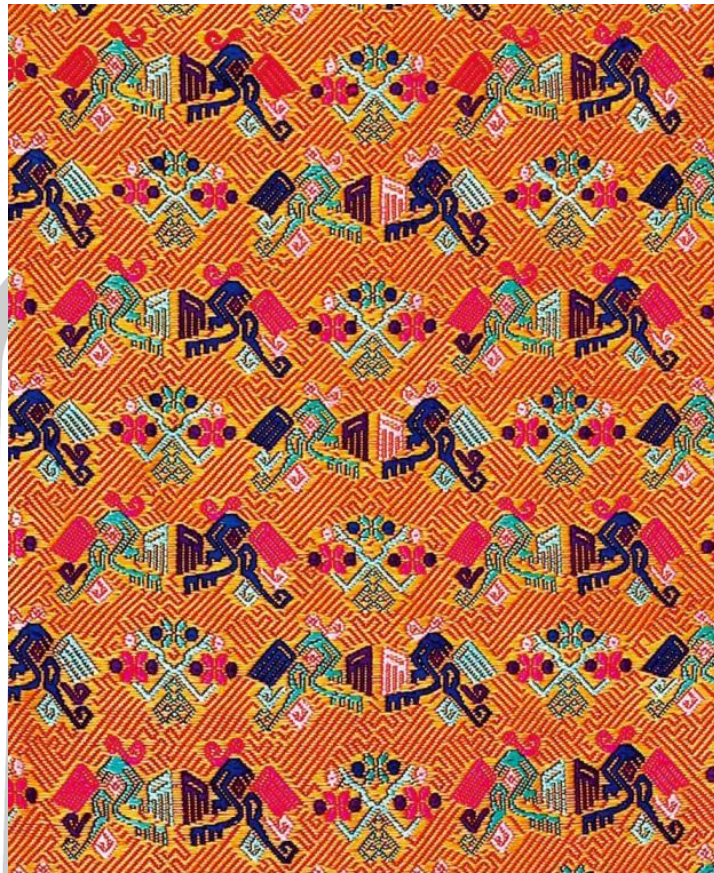


Figure 22 Phoenix flower and tree pattern Zhuang brocade

Source: Photo taken by Yaocheng Tian in brocadegxi brocadeyuan 17 / April / 2023

(3) The god of water worship

Ouluo and its ancestors had rivers and people lived near the water. They were engaged in fishing operations on the water all the year round. After the emergence of primitive agriculture, their dependence on water was further enhanced. However, water not only brings benefits to people's production and life, but also often brings disasters to people. Once the rainstorm comes, flash floods, submerged the countryside, washed away houses, swept away people and animals, people panic, have fled. Sometimes the scorching sun, a long drought does not rain, the river dry, people and animals suffer. People cannot understand the cause of the flood and drought disasters. Under the leadership of "animist concept", it is believed that there is a god in the water dominating the rise and fall of the river, which is called "Tuforehead" (Jiaolong). Thus produced the worship of the water god, both respect and try to suppress it (Figure 23) (Zhang, 1997, P: 226-227).



Figure 23 Water grain is Zhuang brocade

Source: Photo taken by Yaocheng Tian in brocadexi brocadeyuan 17 / April / 2023

(4) King lei worship

As a rice-farming nation, people expect good weather despite their low productivity, because it is related to the survival problem within their ethnic group. In the traditional concept of the local Zhuang people, the dragon (snake), the sun god, the thunder and other gods are in charge of all the wind and cloud, and have the ability to adjust the wind and rain. In the existing and surviving Longzhou Zhuang brocade pattern, you can still see the whole Zhuang brocade with "sun pattern", "cloud thunder pattern", "water pattern", "dragon pattern" and other traditional patterns. These patterns are the works created by combining the feelings of real life and the changing law of nature at that time. Are implied behind these are people by pray for good weather, grain harvest to achieve their life goals, when the will cannot reach one by one, people will be its spirit and rely on "god" to achieve, and the grain is Zhuang brocade important way ancestors communicate gods, convey will (Figure 24) (Zhang, 1997, P: 228-229).



Figure 24 Python dragon pattern Zhuang brocade local thunder pattern

Source: Yaocheng Tian shot at Tan Xiangguang Workshop in Nanning 8 / October / 2023

(5) Vulcan worship

Fire is one of the objects of worship of the Zhuang ancestors. In primitive times, fire could bring many benefits to human beings, such as lighting, heating, cooked food and driving away wild animals, but the raging fire often brought great disasters to people. The primitive man could not understand the characteristics of fire, believing that there was a mysterious power in the role of fire, hence the idea of fire worship. In folk mythology, Buluotuo, the first ancestor of the ancestors of the Zhuang nationality, once separated humans from animals because of the fire. It is said that in the ancient time, the thunder in the sky, the dragon in the water, the tiger in the forest, determined to kill the first god Brotuo to eat. He set off a fire, drove the thunder to the sky, drove the tiger to the forest, and drove the dragon to the water. Thunder was blackened by the fire black face, the tiger was burned to the body has spot marks, the dragon was charred flesh, hurt the scar, become the body of the colorful spot scales. It is also mentioned in the poem that when people do not learn to use fire, they only know raw food, and the body is sick, and with cooked food, the body is strong. Therefore, a reverence for the god of fire has gradually emerged. Fire stove, is a house of fire, people must not put the dirty things on it, but also prohibit the feet on the stove. The fire of the stove is absolutely forbidden with water, only let it extinguish naturally. The Zhuang people still call the New Year's Eve "ndaep", meaning "flameout". The ancient custom was to put out the old fire on this day (in ancient times, kitchen fires were often burned, because there were no matches or fires at that time, and it was difficult to renew the fire), until the first day of the next day. A sacred belief in fire (Figure 25) (Zhang, 1997, P: 226).



Figure 25 Fire grain Zhuang brocade

Source: Photo taken by Yaocheng Tian in brocadexi brocadeyuan 17 / April / 2023

(6) Worship of the land gods

The land is also one of the earliest natural objects worshipped by ou Luo and its ancestors. That " culture, has its distinctive characteristics."That", namely the Zhuang language: na, means "tian" and "dong". Originally it may refer to a paddy field, and in a cave, it refers to a field with mountains around it. That, then generally refers to the fields or land. That culture, namely the land culture of the Zhuang nationality, has thus produced the concept of worshipping the land god. Zhuang and its ancestors of land worship concept and gives the land of divinity or function also experienced a development from single to diverse evolution process, namely by the first Lord and the god of the god of crops, in charge of agricultural production and for the village drive evil, disaster, protect the village peace. His residence was also moved from the outdoor to the god platform of his home, along with the heavenly god and the ancestor god, and he was sacrificed (Qin 1990) during festivals. The folk land worship of the Zhuang nationality is undoubtedly the legacy of the ancient land worship (Figure 26).



Figure 26 Zhuang brocade with field motifs

Source: Photo taken by Yaocheng Tian in brocadexi brocadeyuan 17 / April / 2023

พหุพันธ์ ปณฺ ทิโต ชีเว

Part III: Guangxi Zhuang brocade The social memory in the ritual of life

Zhuang brocade After becoming a tribute, it accelerates its integration into the beliefs and folk customs of the Zhuang people, and quickly spread among the people. Through the ritual events in life, they quickly integrate into the life of the Zhuang people, and the full moon ceremony and wedding ceremony become the bond of affection and love. Then, Zhuang brocade is how to integrate the folk customs of the Zhuang, how to combine the important rituals of the Zhuang in the folk customs.

From the perspective of Chinese folklore, Mr. Zhong brocade gwen believes that life etiquette " mainly includes birth rites, coming-of-age rites, weddings and funerals (NG, 2017, P: 97-100). A complete life experiences the process of birth, growth, marriage, birth, aging and death. Among them, different forms of etiquette are held in the stages of birth, marriage and death, as a sign to distinguish the important nodes of life, meaning the change of individual role and status in the society. Zhuang brocade Art occupies an important position in the traditional folk customs of the Zhuang people, because Zhuang brocade plays a core role in the life etiquette level in the Zhuang society, mainly manifested in the process of birth, wedding and funeral. Zhuang brocade In life etiquette is an important turning point of everyone's life, zhuang pray for the pursuit of the people, in each stage of life to give Zhuang brocade different functions, from the birth of —— wedding —— funeral, Zhuang brocade is endowed with special humanistic value and symbolic significance. Zhuang brocade To become the best carrier for the Zhuang people to convey the feelings of family affection, love and missing. It not only expresses the zhuang people's yearning for love and a better life, but also constructs the indispensable memory material for the Zhuang people, and becomes the password for the zhuang people to pursue happiness. Although Zhuang brocade has not been closely connected with the Zhuang society and folk customs, and even been divorced from the needs of folk customs and social development, it still keeps a lot of social memory information, which is worth in-depth research and analysis.

3.1 Guangxi Zhuang brocade The social memory in the birth ceremony

Zhuang folk concept of blessed and reproductive worship, zhuang to the birth of the new life, usually the birth ceremony including "three dynasties" "full moon ceremony" wine "one hundred" "sell month" ceremony, including "full moon" as the newborn from the clan hall to the most grand etiquette, grandpa, grandma also want to prepare the most expensive gift "Zhuang brocade strap", the strap core woven moral auspicious peace pattern, a symbol of children happiness peace, professional home also want to prepare banquet reception. The full moon wine ceremony in the Zhuang nationality area is different by the region and customs, and there are also some differences. The ceremony basically includes: grandmother quasi this strap —— Xu family do wine, grandmother send strap —— singing "back song" —— back baby shopping and other links, the following brocade gxi City full moon wine as an example, analyze the social memory of the strap.

First, grandma prepared the Zhuang brocade strap

After the daughter of the brocade gxi Zhuang family gets married and becomes pregnant, the grandmother, whether a boy or a girl, will personally prepare the Zhuang brocade strap (Figure 27). Zhuang brocade The strap is usually composed of two parts, the strap core and the strap. The belief in zhuang nationality has a long history. All children born, both men and women, are planted flowers and will be

protected by the flower gods (Chen, 2008, P: 113-114). "Qing dynasty li adjustable yuan" south Vietnam notes "in" white male, red female " records (Liao, 2002, P: 270), usually brocade west back core with full pattern, or flowers, the center of a big flower represents the woman, and the back on the chrysanthemum pattern is also Zhuang people for the goddess of birth mirror armor worship.



Figure 27 Zhuang traditional back strap

Source: Yaocheng Tian shot in brocade National Intangible Cultural Heritage Exhibition Hall 9 / April / 2022

Secondly, Nuxu's family hosted a full-moon reception, and her grandmother gave her the Zhuang brocade backstrap.

After the Zhuang family newborn baby one month, the grandmother presided over a grand full moon ceremony. Usually by the grandmother carrying exquisite "Zhuang brocade strap" as the most important gift (Figure 28), to the son-in-law home gifts, gift team generally more than 10 people, more than 20 or 30 people, son-in-law home to put wine banquet, but also will carry clothes, hats, shoes and socks and other baby supplies to the home. In send Zhuang brocade braces ceremony need both sides singer duet "song", brocade west and both sides singer duet on a day and a night of practice, such as in brocade county south slope township, my grandmother also went to the "full moon", but carried by "generation" (daughter married biological parents bring the bride to the groom's aunt, is also a singer). On the day of the "full moon wine", the congratulatory team led by the "replacement" went to deliver the braces to his grandson. When the team entered the man's door, the in-laws, uncles, sister-in-law, brothers and sisters and relatives had already greeted them at the door. When the grandmother's congratulatory team walked into the grandson's door, the in-law singer waiting at the door held a bowl of fragrant glutinous rice wine to honor the guests he brought to the grandmother, and sang "back song" (Li, 2014, P: 90-97):

Send: wild flowers cauliflower open all over the ground, bees smell fragrant honey, Gold Road silver road rice flower road, grandmother happy with the back.

Main home: gold line, silver line, colorful line, peony blooming in the middle, Lotus lotus with the water, looking at the back with heart.

Send: gongs and drums cry through the clouds, sing the heart fly up and down, Red flower strap back niece, niece happy face crimson.

Owner: grandmother likes to bring back, root silk line sweat bubble, Belt with back you grow up, don't forget grandma love,

Send: white back back nephew, a honey sweet heart. Rain carries the umbrella, wind carries the wall,

Master: My son don't forget that when I was young, I grew up with your back, Is the farmer also want thousands of minutes, reading to understand the truth, Backbelt carries back you grow up, don't forget grandma love.

Singing during the ceremony is also a tradition in the folk customs of the Zhuang nationality. Singing the inner bucket to express the good wishes to the newborn, and also praise the grandmother for sewing the exquisite Zhuang brocade strap. With Zhuang brocade strap as the core, build a Zhuang brocade cultural interaction living inheritance, through relatives and friends and neighborhood watch, review, show the significance of Zhuang brocade as a gift, at the same time Zhuang brocade also become grandmother important media, show exquisite skills, talent and character, as a result, Zhuang brocade from goods to become an important gift in the zhuang society, become the important link of zhuang social family communication.



Figure 28 The strap is made of zhuang brocade

Source: Photo provided by brocadexi Zhuang brocade Factory 9 / April / 2022

Third, Zhuang brocade baby carrier carrying baby shopping

In the brocadexi full moon wine, there is a shopping ceremony to pray for the baby. Generally, a girl is invited to carry the baby with the Zhuang brocade strap sent by her grandmother, symbolizing the connection between the baby and social birth. For example, in Liucheng, brocadexi and other places, there is a full moon shopping ceremony: on the morning of the full moon, please a girl of 13 or 14 years old to put on new clothes, with a new Zhuang brocade back children to the country town shopping. Before going out, the old man handed the girl an umbrella and put a few pages of books and white paper in the arms of the baby, aiming to make the baby courageous and knowledgeable when he grew up (Qin, 1995, P179). The shopping ceremony reflects the good wishes of the Zhuang people to care for and expect the

healthy growth of their children, and trains their children to become knowledgeable talents.

The full moon strap plays an important role in the birth ceremony, a simple strap, condensed the Zhuang people's desire for life inheritance, from the deep meaning and perception of Zhuang brocade and the life society, at the same time, Zhuang brocade strap also carries the faith and culture of the Zhuang people, Zhuang brocade also becomes the bond of family love.

3.2 Guangxi Zhuang brocade, the social memory in the wedding ceremony

Since the Qing Dynasty, Zhuang brocade has become one of the necessary dowry for the Zhuang women to prepare. For example, in the 25th year of Guangxu, Yan Sihui wrote in the Annals of Zhili Prefecture: " For the dowry, the soil brocade must not be less, and everyone in the hometown can weave the reason. Soil brocade with willow velvet for it, with five colors, thick and durable, the value of five two, not ji daughter is learning to weave ", the Republic of China" brocadedexi County Annals "in the" custom "said:" male family betrothal gift, as usual to send betrothal gold and pig, sheep, goose, goose, duck, chicken wine seafood candy and other things. Female dowry used earth, brocade, bedding, blankets, curtains, shoes, socks, POTS and bowls (Feng, 1948)."The new" brocadedexi County Annals "in the" marriage customs "section mentioned that" female dowry must have Zhuang brocade quilts, felt blankets, mosquito nets, curtains, furniture, cooking utensils, the amount depends on the employment money."(County Annals Compilation Committee of brocadedexi County, Guangxi, 2000, P: 759). Zhuang marriage custom influenced by times and social customs, from the qing dynasty to the 1970s, Zhuang brocade become the zhuang people's marriage indispensable items, xincheng, yizhou, Hechi, huanjiang, brocadedeg west, the slope, dragon, new area of zhuang still along the tradition, five, six bed Zhuang brocade face become zhuang women dowry is the most important items, indispensable items (Figure 29).



Figure 29 The groom Huang Guozhu and the bride Lu Xiaofang held a traditional wedding

Source: Guangxi News Network Fan Shaoguang shot 17 / January / 2024

Zhuang brocade Become an important social media in the wedding ceremony, through the exquisite Zhuang brocade become to show the wisdom, talent and character of Zhuang women. At the same time, Zhuang brocade, as a symbol of wealth, Zhuang brocade is a means to improve the social status and respect of Zhuang women. Marriage, as a ceremony of concentrated display of social relations and culture, Zhuang brocade In the wedding ceremony of the symbolic multiple meanings: one is Zhuang brocade how many faces, To symbolizes the wealth and status of the family, Zhuang brocade The more of the surface, The more exquisite the pattern is, The more it shows the abundance of the family; The second is the exquisite degree of the Zhuang brocade surface, It symbolizes whether the new daughter-in-law is skillful, industrious and intelligent, It is an important measure of whether zhuang women have ability, Has the unlimited potential to create wealth for her in-laws; Third, the wedding to Zhuang brocade is the face as the interface, Sym symbolizes whether the bride's new social identity is recognized, Is an important indicator of recognition from the in-laws and others, Show and gain dominance in the family, Effectively safeguard the interests of their housewives; Fourth, the Zhuang brocade is also the identity of the Zhuang people, It symbolizes the desire of the people of the Zhuang nationality to pursue a better and happy life. For example, in 1987, the "brocadexi brocadexiu" described a Zhuang family is doing marriage, the girl's dowry is all placed in the door display, in addition to the three-door cabinet, clothes and a variety of supplies, is a big bed stacked with three quilts, the face is all Zhuang brocade. That Zhuang brocade the pattern is chic, exquisite pattern, gorgeous color, once attracted us, as if in this partial cake mountain township found a famous painting. Look, one is the pale blue water grain on the bottom, two gorgeous mandarin duck in the lotus, green lotus trapped group, bright flower feeling, green swim reflected, remind people of Li Yi's "long dry line" in the poem: "Mandarin duck green pu, jade brocade screen". One is ten thousand words of chrysanthemum, with five light thirteen color velvet woven, the clouds like the lining, like the sky, and the posture of different chrysanthemum, " and like the garden chrysanthemum blooming, pleasing to the eye. One is a peony rooster, a cluster of peonies beside the stone, the rooster is independent, singing high, the distance is red miles, full of vitality. Open wardrobe hanging a satchel, satchel woven galloping horse with purple, bottom green, edge with light yellow back grain silk thread, the jujube red horse, ang empty long taste, Pentium leap, give people the strength to make up (Bao, 1987, P: 135-138). Another example in 2009 brocadexi brocade artist Huang Yueping recalled: " before married, must be a bed Zhuang brocade is face, this is our custom... if there is a Zhuang brocade is face dowry, whether the husband's family are good scenery... can not send, will be criticized, be looked down upon for a long time (Ning, 2010)."Zhuang brocade The" dowry " brought from the mother's family has both wealth value and spiritual value, The Zhuang brocade face can ensure the material life of the bride, Exquisite brocade skills can also create unlimited wealth for the family, last, Zhuang brocade Become the image of the intelligent, kind, industrious and capable reflection of the Zhuang women, And give Zhuang brocade the symbolic meaning of love, It is also the yearning of the Zhuang people to pursue a better and happy life in the future (Figure 30).



Figure 30 Phoenix bird wearing flowers Zhuang brocade quilt face
 Source: Photo taken by Yaocheng Tian in brocadegxi National Intangible Cultural Heritage Exhibition Hall 17 / April / 2023

3.3 Guangxi Zhuang brocade, the social memory in the funeral ceremony

There are few records about the use of Zhuang brocade in funeral ceremonies. After the death of the elderly in brocadegxi area, their clothes and brocade will be burned, which is also the traditional method of dealing with the old Zhuang brocade. This custom also caused Zhuang brocade to be made in modern times, while Zhuang brocade was relatively rare in the Ming and Qing Dynasties. Zhuang brocade Used for funeral is also a custom of ancient burial of Zhuang ancestors. The Zhuang people in Longzhou, Guangxi, still keep Zhuang brocade for funeral ceremonies.

Longzhou Zhuang people attach great importance to funeral, because in their eyes, funeral is the most important etiquette in life, which is related to the "cycle of life and death". First of all, Zhuang brocade covers the funeral hall. At the funeral of Longzhou brocadelong Zhuang Budai Village, the "yao gong" of the Zhuang people should be invited to be the soul of the deceased, and Zhuang brocade should cover the funeral hall. The number of Zhuang brocade covered is generally determined by the age of the dead, and the Zhuang brocade is odd, which cannot exceed nine. Secondly, Zhuang brocade becomes the link of communication cycle. The local Zhuang people believe that the Zhuang brocade with important faith symbolic significance, placed above the funeral of the deceased, can bring Zhuang brocade from the deceased to another world to continue to use it. At the same time, they can also "return to the family" through Zhuang brocade. Finally, Zhuang brocade is the source of the Zhuang people's pursuit of happiness. The Zhuang brocade used by the deceased covers the funeral hall, playing a role in escorting the deceased, so that the deceased can continue to be happy in another world.

Therefore, Combined with the "social memory" cultural schema formed by Zhuang brocade in the course of history, It is inferred that Zhuang brocade was basically after the emergence of "Guangxi brocade" in the Southern Song Dynasty, Brocade technology began to spread widely in the Guangxi Zhuang region, Under the promotion of the local officials in the Ming Dynasty, the zhuang brocade ——Zhuang brocade, Zhuang brocade After the development of the Ming and Qing Dynasties, Zhuang brocade It eventually becomes the "happiness code", "symbol of love", "wedding symbol" and "bond of family love" of the Zhuang nationality. Like the classic song in the Zhuang opera Zhuang brocade:

Zhuang brocade It is the strong spring planting and autumn harvest,
 Zhuang brocade Is the strong family of heaven,
 Zhuang brocade It is amama's weaving,
 Zhuang brocade It is the source of happiness pursued by their children.

Part IV: Guangxi Zhuang brocade, social memory in daily life

This section studies the analysis of Guangxi Zhuang brocade, social memory in daily life. It is divided into two parts. The first is the memory of Guangxi Zhuang brocade in daily life before reform and open to the outside world; the second is the memory of Guangxi Zhuang brocade in daily life after reform and open to the outside world.

4.1 Guangxi Zhuang brocade Memory in daily life before reform and open to the outside world

(1) Memory in social activities

Zhuang brocade As a traditional ethnic products and hand arts and crafts, it has a deep mass foundation. In the Zhuang area, there was once a scene where every family had a loom and all women could weave brocade. In the folk, Zhuang brocade is mainly used as braces and quilt, but also used for cigarette bags, waist wallets, bags and baggage, is a precious daily necessities and gifts. When girls get married, brocade is an indispensable dowry, and they had to weave it carefully when they were in teens. They thought that a girl did not understand brocade, and that her relatives and friends despised it, and the young man did not like it. With children, parents and friends had to send brocade and grace, girls often gave their elaborate works as gifts of love, up to many places in Guangxi (Liu, 2007, P: 74-75). Therefore, every festival, polder day, visit relatives and friends or attend weddings, girls often wear clothes decorated with exquisite Zhuang brocade or carry Zhuang brocade embroidery bag, with their exquisite skills to cause the love of young young men and pursuit.

First, Zhuang brocade became the courtship symbol of zhuang men and women

Every festival, polder, visit relatives and friends and attend the wedding banquet, the girls are carrying with Zhuang brocade of various necessities Zhuang brocade bag, hydrangea, sachets, etc., or wear with embroidered Zhuang brocade scarf, clothes, pants, belts, apron, etc., for ingenuity and beauty, with their exquisite craft to attract people's attention and young love, pursuit (Yu, 1992, P: 44-48). So the Zhuang girls began to learn brocade, prepare their own dowry. On annual festival, polder day, visiting relatives and friends or wedding banquet, the girls 'Zhuang brocade bags, sachets, clothes, pants, belts, aprons with Zhuang brocade become the display of zhuang girls to show their beautiful talent and virtue, thus attracting

people's attention and the favor of young men. It is essential for most ceremonies and social exchanges (Bai, 2006). Its role is even more particularly prominent in the wedding. For the Zhuang people, the traditional Zhuang brocade has the meaning of friendship in the communication between Zhuang people. Take their favorite and full of beautiful Zhuang brocade as a gift to arouse people's infinite longing and blessing for a better life. The Zhuang boys appreciate the brocade skills of the Zhuang girls as they are sung in the Zhuang love songs (Liu, 1995, P: 27):

A-mei throw jade shuttle, color line into mountains and rivers;
 A-mei woven flowers, butterflies fall up;
 A-mei weaving carp, shaking the tail to the river;
 A-mei knit small birds and can sing.

Second, Zhuang brocade has become a condition for Zhuang men to choose a mate

In farming civilization society dominated by "male plow female weave" under the traditional way of life, Zhuang folk customs that a girl handicraft exquisite is one of the important signs of the smart, women's gender role, status directly through Zhuang brocade different forms, Zhuang brocade art good or bad directly reflects the woman "ingenuity", related to the girl's marriage and future. Qing Dynasty Shen Lisen's "The west of Western Province" cloud "Zhuang women are quite skilled, dyeing silk and brocade colorful rotten." "As a nation, men ploughing and women weaving is the production mode of the Zhuang people." This is not only the result of natural selection, but also the traditional division of labor of 'natural' for men and women in social production activities.(brocade,2006)". Therefore, brocade is a necessary production skill for Zhuang women. Zhuang girls often treat learning Zhuang brocade skills as a major event in life, because how brocade technology is the Zhuang folk to measure whether women are industrious and virtuous standards. They make use of their leisure time and leisure time, and devote a lot of ideas to weaving a Zhuang brocade, and then embroider it on the clothing, or make a variety of daily necessities, which is not only for material satisfaction, but also an enjoyment of the pursuit of beauty and spiritual heart (Yu, 1992, P: 44-48).

Third, Zhuang brocade has become a bond for Zhuang women to participate in social interaction

At the age of 11 or 12, Zhuang women began to learn brocade "female workers". Qianlong of the Qing Dynasty had a record of "returning to Zhili Prefecture". Qing ren Mo Zhen "Xincheng bamboo branch word" "in July mountain city lights, every brocade to three more, after the chicken singing shuttle, and listen to the sound of anvil", recorded the Zhuang women at that time fine brocade female red scene. After four or five years of study, to 16 years old can independent textile, can textile Zhuang brocade things to others, began formal social interaction, complete the secret transition of female bar mitzvah. In the annual polder day or wedding birthday banquet and other occasions, can be self-woven Zhuang brocade bags, sachets, gift to relatives, friends, but also their most satisfied Zhuang brocade shoulder bag as a token of love gift to the friend. Thus, it officially started its social activities as an adult woman, thus forming new social relationships and social networks (Li, 2014, P: 90-97).

(2) Memory in business activities

Textiles have become important commodities, and brocade has always had the saying of "gold", which describes the high value of brocade. From "Guangxi brocade" to an important material of Yima in the Southern Song Dynasty, the brocade in Guangxi also entered the era of commodity exchange. And Guangxi kam in Guangxi widespread important force, is in the commodity power, soon accepted by the Zhuang people, and form the family for workshop production mode, such as in his word XinCheng bamboo written "July mountain city lights, every brocade to three more" poem, describes the busy XinCheng folk brocade scene. In the Ming Dynasty, "Guishun Zhili State Annals" recorded: "Soil brocade, woven with silk and cotton, is luxuriant, luxuriant, the waves, day Wu Zifeng also, the state is thick." Basically similar to the materials, colors and textures of modern Zhuang brocade production. "Qingyuan Fu Annals" records: "Xincheng Tu County year for soil brocade four colors, as long as 20 end, decorative silver 46 two money, by the government salt method." In the production of tribute in addition to the use of silk and cotton materials also use silver as decoration, to enhance the exquisite degree of Zhuang brocade, to meet the requirements of tribute. Qing dynasty Zhuang brocade except as tribute, began to use in the folk, Zhuang brocade become Zhuang valuable textiles, such as the Qing dynasty gold repair "Guangxi tong zhi" said: "Zhuang brocade states out, strong people love color, all is is take five color down, mixed with weaving for flowers and birds, far view work qiao dazzle li, myopia and thick, strong people expensive." **Yan Sihui wrote in the "Gui Shun Zhili State Annals : "To marry the dowry, the soil brocade can not be less, and everyone in his hometown can weave the same".** Soil brocade with willow velvet for it, with five colors, thick and durable, the value of 50 two, not ji daughter is to learn to weave.". Zhuang brocade became more expensive as it became an important part of the dowry. Another example is Shen Rilun's "Records of Western Guangdong Province" wrote Zhuang women "skilled, dyed silk brocade colorful, and silk, can be a mattress. All your officials and rich businessmen, never fight for them." With the continuous development of folk Zhuang brocade skills, Zhuang brocade began to become a commodity of foreign trade, and the scene of expensive officials and rich businessmen competing for prosperity appeared.

4.2 Guangxi Zhuang brocade in memory in daily life after reform and open to the outside world

This subsection analyzes Guangxi Zhuang brocade memory in daily life after reform and open to the outside world. It is divided into two parts. The first is the memory of Guangxi Zhuang brocade in daily life from 1978 to 2006; the second is the memory of Guangxi Zhuang brocade in daily life from 2006 to 2023. After the reform and open to the outside world, Zhuang brocade Also entered the market-oriented economy, Zhuang brocade Development into a brief revival, By the 1990s, Due to many problems, such as operation and management, Zhuang brocade Basically disappeared in the Zhuang nationality gathering ground in Guangxi, Mainly retain a few Zhuang brocade plants, In 2006, after Zhuang brocade technology became the first batch of national intangible cultural heritage projects, Point a new direction for the development of Zhuang brocade.

(1) Memory of Guangxi Zhuang brocade in daily life in 1978 - 2006

Reform and open to the outside world Early, Zhuang brocade is not only used to meet the basic function of daily life, more used to maintain social daily communication relations, at the feast, fair, visit friends or attend the wedding banquet, girls wear woven, Zhuang brocade dress, such as clothes, scarf, apron, sachets, bag, these "outside" as the performance of its inner image, constitute the social discourse and power relations. Such as sha red in the decorative pattern of Zhuang brocade is described the zhuang guy fly on the machine, not only can make "rosy clouds in the light flying, flowers in the colorful", but also on the Zhuang brocade woven into the "machine plow road iron cattle in Mercedes", "female tractor hand in the blue sky", so that "brocade machine spectrum out of the era of new rhyme" (Tao, 1984, P: 13-20). It reappears the need of Zhuang brocade to keep up with the development of The Times. Zhuang brocade It is closely related to the life course of the Zhuang people and permeates into their daily life. As a national art, Zhuang brocade is an important means for the strong people to express their emotions and understand their life. To some extent, brocade constitutes the way of life of the strong people, and its skills are also a unique art form. Zhuang brocade The artistic characteristics are closely linked with their folk life, permeated with a strong local flavor. Zhuang brocade It is a true portrayal of the strong people's daily life, and the brocade skills are naturally consciously inherited and developed in the rural society. However, with the change of life mode, brocade art is no longer a necessary skill in life, and its creation and consumer groups have been greatly reduced. Zhuang brocade The commercialization and marketization make it change from daily supplies to "decentralized" decorations, leading to the rupture of the self-tradition of national art.

(2) Memory of Guangxi Zhuang brocade in daily life in 2006 - 2023

First, market openness and the rise of Zhuang brocade

In 2006, after the Zhuang brocade technique became a national intangible cultural heritage protection, Zhuang brocade is not only a handicraft, but also has become an important part of the Zhuang culture. It not only represents the wisdom and creativity of the Zhuang people, but also shows the treasures of traditional Chinese culture. In the blend of tradition and modernity, Zhuang brocade radiates new vitality and vitality, bringing people the enjoyment of beauty and the gluttonous feast of culture.

The second is the change of Zhuang brocade's sales mode

Reform and open to the outside world Since then, Zhuang brocade's production and sales model has undergone changes. From traditional family brocade to collective management or corporate management, the combination of market operation and brand promotion enables Zhuang brocade can be widely displayed and promoted. In addition, Zhuang brocade has gradually entered the international market and become an important model of Chinese ethnic handicrafts. Zhuang brocade The industry increasingly pays more attention to brand building and market expansion. By participating in domestic and foreign exhibitions and art exhibitions, we will actively expand sales channels and enhance product visibility and influence.

Third, the Zhuang brocade pattern is widely used

Adapadapt to market dynamics and trend changes, Zhuang brocade industry pays more attention to innovation research and development and product optimization. Widely used in clothing, home decoration, gifts and other fields, Zhuang brocade application examples. Such as integrating it into the fashion design, and skillfully combining with the modern elements, to create a unique clothing style. At the same time, Zhuang brocade also permeates the home decoration, such as curtains, carpets and other products, giving the interior space a strong cultural atmosphere. By introducing novel materials, techniques and patterns, Zhuang brocade products are infused with more fashionable and modern elements, and are widely favored by consumers.

Fourth, the artistic value and protection of Zhuang brocade

With the deepening of people's understanding of Zhuang brocade's cultural value and artistic value, Zhuang brocade artists have endowed Zhuang brocade with new vitality and characteristics of The Times through innovative design and technology improvement. Zhuang brocade The inheritance and protection has been widely concerned, and the Chinese government has issued relevant policies and measures to ensure the continuation and development of their traditional skills. The local government also strongly supports the protection and inheritance of Zhuang brocade skills, and introduces a series of policies and measures to encourage the inheritance of traditional skills, cultivate young weavers, and protect raw materials and production environment, so as to ensure the continuation and development of Zhuang brocade.

Part V: Guangxi Zhuang brocade The social memory in the inheritance

Zhuang brocade In the inheritance process of nearly one thousand years, there are two main forces to promote the inheritance, one is the inheritance of Guangxi Zhuang brocade technology; the other is the inheritance of Guangxi Zhuang brocade art. There are many social memory information hidden in the technology inheritance, such as how Zhuang brocade inherits in the family unit? How to pass on through master and apprentice? How to inherit skills through oral transmission? And the inheritance of fabric craftsmanship under modern technology? These are the important driving forces for Zhuang brocade transmission. In addition, there are also three types in Zhuang brocade art inheritance, the first imitating the traditional pattern, the second innovative pattern, and the third proverb guides color collocation. Has virtually contributed to the two forces of Zhuang brocade continuous inheritance.

5.1 Guangxi Zhuang brocade, the inheritance and memory of skills

(1) Family teaching-style inheritance and memory

Zhuang brocade The skill is driven by family inheritance, There are three main aspects: first, The Commercial Value of the Zhuang brocade, In becoming an important production commodity for small-scale peasant economy families, Although not a major financial source, It is also an important source of subsidies to the family economy; 1,2 It is, therefore, Zhuang brocade Is an indispensable thing in the dowry of the Zhuang daughter, To learn the art of Zhuang brocade from 12 to 13 under the guidance of parents, By the age of 16 to 18 they were able to weave Zhuang brocade, And as a love gift or to prepare a dowry. Third, Zhuang brocade skills symbolize the ability of Zhuang women. Whether or not Zhuang brocade can be woven well

becomes a sign to measure the ingenuity of Zhuang women. Therefore, Zhuang women generally begin to learn Zhuang brocade skills from their mothers in their teens. Officially promoted by these three forces, Zhuang brocade skills are continuously inherited as a family unit. However, under the influence of the market economy, the Zhuang families now basically have no brocade living ecology, and a few remote Zhuang gathering places retain the family brocade skills. For example, Zhuang brocade in Longzhou has been very active in this area since the late Qing Dynasty. Although Zhuang brocade here is also impacted by modern commodities, the inheritance of brocade skills taught by the traditional family still retained in Li Suying's home in Banchi tun, Shuangmeng Village, brocadelong Town, Longzhou (Table 9).



Genera- tion	surnam- e and persona- l name	sex	nation	date of birth	degree of educati- on	The direction of inheritanc- e	Art time	Upper and lower generati- ons
first genera- tion	Yellow type willow	wom- an	the Zhuang national- ity	not quite clear	an illiterat- e person	handed down from one's ancestors	not quite clear	not quite clear
second genera- tion	Huang's piece	wom- an	the Zhuang national- ity	In March , 1909	an illiterat- e person	handed down from one's ancestors	not quite clear	Mother- in-law and daughter- in-law, apprenti- ce
third genera- tion	Huang Mei bead	wom- an	the Zhuang national- ity	In May, 1934	old- style private school	handed down from one's ancestors	In 1950,	Mother and daughter , master and apprenti- ce
The fourth genera- tion	Qin Xiuqin g	wom- an	the Zhuang national- ity	In Nove- mber, 1954	primary school	handed down from one's ancestors	In 1970,	Mother- in-law and daughter- in-law, apprenti-
The fifth genera- tion	Li Suying	wom- an	the Zhuang national- ity	In August, 1977	junior middle school	handed down from one's ancestors	In 1989,	Mother and daughter , master and apprenti- ce

Table 8 Brocade inheritance lineage of Li Suying Family, Shuangmeng Village, brocadelong Town, Longzhou

Source: Fan Daozhi.(2019). Study on brocade techniques of Zhuang nationality in Longzhou, Guangxi (Master's thesis, Guangxi University for Nationalities).

At present, Li Suying is the fifth generation inheritor of Longzhou brocadelong Zhuang brocade and the representative inheritor of Longzhou brocadelong Zhuang brocade skills, an intangible cultural heritage project at the autonomous region level. She has learned to weave Zhuang brocade from her family since childhood, and her two younger sisters, Li Sufang and Li Sufen, and her two daughters, Li Siying and Li Siyi, are known as the "five golden flowers" (Figure 31) of the Zhuang brocade family.



Figure 31 Longzhou Zhuang brocade family "five golden flowers" (from the front row: Li Siying, Li Suying, from the back row: Li Siyi, Li Sufen, Li Sufang)

Source : <https://m.thepaper.cn/baijiahao> 17/January/2024

Li Suying has been watching her mother weave Zhuang brocade since she was young. She began to learn brocade techniques from her mother at the age of 12. Under her mother's careful guidance, she quickly mastered the skill of brocade. On the basis of her predecessors, she has kept innovating and created many new products with both national characteristics and historical background.

Li Suying's two daughters, Li Siying and Li Siyi, have learned to weave Zhuang brocade from their mother since childhood and participated in brocade performances everywhere. Both sisters learned to weave Zhuang brocade at the age of 8. Sister Li Siying was good at knitting some brocade brocade ribbons when she was in junior high school, and embroidered them on the collar, sleeves and dress legs of ethnic costumes, making traditional ethnic clothes more beautiful and fashionable. Li Siying said: " My mother's back on the brocade machine has become the most profound memory in my childhood. The brocade machine can be regarded as my childhood playmate and accompany me to grow up." She has been practicing brocade for more than an hour a day since the age of six. Brocade is not easy to learn, especially the technology of cross-stitch, each step requires the combination of eyes and hands, but also need to learn to hide the thread, weave into a complete pattern. Under the guidance and encouragement of their mother, Siying and Siyi overcame the difficulties and finally mastered the brocade art (Figure 32).



Figure 32 Li Suying instructs her daughter Li Siyi to weave Zhuang brocade
Source : <https://m.thepaper.cn/baijiahao> 17/January/2024

In addition, Longzhou County attaches great importance to the inheritance and development of intangible cultural heritage, and employs skilled Zhuang brocade artists to teach Zhuang brocade weaving skills (Figure 33) for children or young people in their spare time.



Figure 33 Longzhou County Zhuang brocade artists are directing children to weave
Zhuang brocade
Source : <http://www.gxnews.com.cn> 17/January/2024

(2) Inheritance and memory

Mentoring is an important means of inheriting Chinese folk art, and Guangxi Zhuang brocade is no exception. In the story of Zhuang brocade's invention, after the invention of Zhuang brocade, the women around him began to teach brocade techniques, and over time, the Zhuang brocade techniques were widely spread in the Zhuang gathering places. In the early inheritance of Zhuang brocade, there is no clear record of the apprentice, but through the information of legends, such as the origin of Zhuang brocade, "All the strong women come to learn brocade from Dani", Zhuang brocade technology broke the inheritance of the family and formed the foundation for wider dissemination of brocade skills. As described in the story of Moran's invention of color Zhuang brocade: "Moru's wife learned that Moran could weave color Zhuang brocade, she invited her to the yamen to teach technology. Moran is very generous, in addition to the yamen to teach technology, but also passed to other villagers." In the Ming and Qing dynasties, Zhuang brocade, as a technology, was taught in official institutions, which was the earliest case of Guangxi Zhuang brocade mentoring. In addition, in 1921, Jane women in Xincheng County went to Chengdong Gate Street, Binyang County and Wang brocademing Village, Luwei Township to teach Zhuang brocade weaving skills. At present, the inheritance has formed a scale, mainly binyang Zhuang brocade and brocadegxi Zhuang brocade factory.

First, Binyang Zhuang brocade learned from the memory

Binyang area is mainly Han nationality. In the 24th year of the Republic of China (1935), Liang Shuying (17 years old) of Binyang Han nationality went to the home of Zhuang women surnamed Lu in Xincheng to learn the skills of Zhuang brocade. Here, Liang Shuying studied hard and mastered the skills of Zhuang brocade in Xincheng. After Liang Shuying mastered the Zhuang brocade skills of Xincheng, he selflessly taught the Zhuang brocade skills to Binyang, which improved the level of Binyang brocade on the whole and played a role in promoting the development of Binyang brocade.

In 1956, in the early days of the founding of new China, Binyang County, corresponding to the national policy of protecting ethnic folk technology, vigorously supported the production of Zhuang brocade. The brocade cooperative named "Yufu" was established, and relying on the cooperative and the later established Binyang National brocade and other organizations, the mentoring inheritance of Binyang Zhuang brocade began. It has developed to three generations, Binyang Zhuang brocade mentoring inheritance appeared two Chinese arts and crafts masters, respectively, Liang Shuying and Tan Xiangguang. They are very successful cases in the Zhuang brocade mentoring inheritance.

Case 1: Tan Xiangguang learned to weave Zhuang brocade

In 1970, Tan's parents sent the 15-year-old to a Binyang brocade craft factory to study and work. After more than a year of hard work, Tan Xiangguang showed his talent for brocade. In 1971, she officially learned the art of brocade from her teacher Liang Shuying. Starting from basic painting, Liang taught her to design square patterns and Zhuang brocade's design, weaving and programming techniques. Before long, Tan Xiangguang systematically mastered all the processes of Zhuang brocade spinning, pattern design and loom cross-stitch, and boldly and innovatively designed and made Zhuang brocade. Miss Liang has been studying with her for 13 years. Finally, Tan

Xiangguang injected vitality into the development of Zhuang brocade with his exquisite Zhuang brocade skills and innovation ability, and became the second Chinese arts and crafts master in Zhuang brocade history. In addition, in order to better master the patterns on the Zhuang costumes and understand the customs and taboos of the Zhuang nationality, Liang Shuying and his apprentice Tan Xiangguang went to the gathering places of the Zhuang nationality many times to collect the traditional Zhuang patterns. Through tracing, learning and inheriting the traditional pattern, it has laid a solid foundation for Tan Xiangguang's subsequent innovation of Zhuang brocade pattern.

Case 2: Huang Aiqun learns brocade from Tan Xiangguang

The author went to Xiangguang Brocade Workshop in Binyang County and interviewed with Ms.Huang Aiqun, the third generation inheritor of Binyang Brocade (**Figure 34**), She said: under the influence of her mother, I like the dazzling Zhuang brocade since my childhood, And learned simple brocade techniques from his mother, Later to 1989, I formally worship Tan Xiangguang as a teacher, Systematic learning of brocade techniques, One of the most difficult is to master the flower weaving process, Different patterns require different ways of weaving, It takes a lot of time for memory and practice, In order to master the whole technical process from the craftsman's intention to the Zhuang brocade finished products. Teacher Tan also guided me, as a good weaver, to have a quiet character, to be skillful and careful, but also to have the hobby of painting and weaving, embroidery, from the folk art of artistic nutrients. Later, Ms.Huang was worried about the future development of Zhuang brocade, and said that she would also strive to inherit the Zhuang brocade skills, and continuously activate and inherit the intangible cultural heritage technology.



Figure 34 Photo of Tian Xiaocheng and Ms.Huang Aiqun (Tian Yicheng the left, Huang Aiqun in the middle, and Huang Peijun on the right)

Source: Yang Na took photos in 17 / November / 2023, Binyang County

After field investigation and the data provided by Ms.Huang Aiqun, the lineage of Binyang brocade inheritance was counted (Table 10):

Generation	surname and personal name	sex	year of birth	culture	The way of inheritance	Teacher time
First generation	Liang Shuying	woman	In 1919,		Learn from Xincheng Lu women learning Zhuang brocade	In 1935,
Second generation	Tan Xiangguang	woman	In 1955,	primary school	Learn zhuang brocade from Liang Shuying	In 1970,
	Wei Lixia	woman	In 1960,	primary school	Learn zhuang brocade from Liang Shuying	In 1975,
Third generation	Huang Aiqun	woman	In 1960,	junior middle school	Learn zhuang brocade from Tan Xiangguang	In 1989,
	Qin Peijuan	woman	In 1967,	senior middle school	Learn zhuang brocade from Tan Xiangguang	In 1995,
	Fan Lihua	woman	In 1994,	junior college	Learn zhuang brocade from Tan Xiangguang	In 2015,

Table 9 Binyang Zhuang brocade inherits the relationship inheritance lineage

Source : Yaocheng Tian, Author: 17/January/2024

Second, brocadezxi Zhuang brocade learned from the memory

brocadezxi Zhuang brocade started in 1956, and under the guidance of the government, the brocade artists scattered in the families were gathered together to learn and produce Zhuang brocade together. After decades of development, after many innovations, the company operates zhuang Zhuang brocade skills in the form of the company, and cultivates generation after generation of brocade artists. At present, brocadezxi Zhuang brocade has developed to the seventh generation of inheritance. brocadezxi Zhuang brocade teacher has the following characteristics: first, there is no clear inheritance, but can lead apprentices; second, brocadezxi brocade teacher selection apprentices do not have strict requirements, as long as love, can adhere to the brocade will recruit apprentices (Figure 35,36,37).

As shown on July 25,2021, Interviewer: Shi Xiaorui, Zhu Qide interviewed brocadezxi Zhuang brocade factory director Li Cunling, she said: as long as you can learn to love learning to teach, After a while, we feel ok, we stay, Because not everyone comes in and does it, Some of them are very poorly made, On the wrong side, I said, And to do it very slowly, Sometimes it doesn't work, Look at it, too, You think people are a little more intelligent, And even more handy, And it can withstand it, And the idea has to be innovative by itself, If you are not innovative, You can keep your old words from shining, So sometimes like we weaver weaver sometimes think, How can we better improve the efficiency, But it's hard to find people (Shi, &Zhu, 2021). Then, on August 6th, Interviewer: When Shi Xiaorui interviewed Li Cunling, the factory director of brocadezxi Zhuang brocade Factory, again, She said: We used

to be from family, Grandmother to mother, Mother passed it on to the daughter and so on, But after we set up our factory, A lot of brocade came to the factory, Not as passed on within the family, Those who can brocade will bring apprentices, Conduct the professor, This way of teaching is that the older generation teaches the next generation, The next generation teaches the next generation, I have been teaching it until now, Now we're actually in the sixth generation, the seventh generation, And then we're already started developing the eighth generation. But now training is different from before, used to be only the church brocade, now the development of science and technology, need a lot of new patterns, you will only weave not do, so we have to develop to brocade and understand computer design, but it is hard to find, now young people rarely to learn this (Shi, 2021).



Figure 36 Professor Zhuang brocade pattern of brocadegxi Zhuang brocade Factory
Source: Courtesy of Jingxi Zhuang brocade Factory 17 / October / 2023



Figure 37 brocadegxi Zhuang brocade factory professor Zhuang brocade weaving flowers

Source: Courtesy of Jingxi Zhuang brocade Factory 17 / October / 2023



Figure 38 The Zhuang brocade pattern is discussed in brocadegxi Zhuang brocade Factory

Source: Courtesy of Jingxi Zhuang brocade Factory 17 / October / 2023

brocadegxi Zhuang brocade from 1956, gathered brocade artists to Zhuang brocade factory to weave brocade together, and taught the skills through the way of the master and apprentice. It has developed to the seventh generation of inheritors. In addition, director Li Cun Ling said that he was training the eighth generation of Zhuang brocade inheritors. After field investigation and the data provided by Director Li Cunuling, the inheritance of the mentoring pedigree of Zhuang brocade Factory in brocadegxi City is counted, as shown in the following table (Table 11):



Generati on	surname and personal name	sex	date of birth	degree of educatio n	Art way	Art time	Hom e Add	rem ark s
first generation	Xiu-lin peng	wo ma n	In 1904,	not quite clear	Teacher biograp hy	not quite clear	broca degxi City Xinbr ocade g Town	
	Liu brocadelan	wo ma n	In 1916,	not quite clear	Teacher biograp hy	not quite clear	broca degxi City Xinbr ocade g Town	
	Yan Qizhong	wo ma n	In 1918,	not quite clear	Teacher biograp hy	not quite clear	broca degxi City Xinbr ocade g Town	
second generation	Xue-fang huang	wo ma n	In 1927,	not quite clear	Teacher biograp hy	In 1953,	broca degxi City Xinbr ocade g Town	
	Huang Xuefen	wo ma n	In 1929,	not quite clear	Teacher biograp hy	In 1955,	broca degxi City Xinbr ocade g Town	
third generation	Huang Yueping	wo ma n	In 1945,	primary school	Teacher biograp hy	In 1967,	broca degxi City Xinbr ocade g Town	
The	Chen Ye	wo	In	junior	Teacher	In	broca	

fourth generation		man	1948,	college	biography	1969,	degxi City Xinbrocade g Town	
The fifth generation	Chen Luzhen	woman	In 1957,	junior middle school	Teacher biography	In 1975,	broc degxi City Xinbrocade g Town	
	Yang Li and	woman	In 1959,	junior middle school	Teacher biography	In 1978,	broc degxi City Xinbrocade g Town	
The sixth generation	Li spirit village	woman	In 1967,	special school	Teacher biography	In 1982,	broc degxi City Xinbrocade g Town	National non-genetic inheritors
The seventh generation	Gu Rui pickup	woman	In 1973,	senior middle school	Teacher biography	In 1998,	broc degxi City Xinbrocade g Town	
	Qin Huixian	woman	In 1976,	senior middle school	Teacher biography	In 2002,	broc degxi City Xinbrocade g Town	

Table 10 Inheritance pedigree of brocade degxi brocade (the author arranges according to the data provided by Zhuang brocade Factory)

Source : Yaocheng Tian, Author: 17/January/2024

5.2 Guangxi Zhuang brocade, the inheritance and memory of art

(1) Imitation of the brocade pattern

The ancestors of the Zhuang people took the patterns as the object of hope and the source of faith. These patterns are closer to a supernatural existence, which can enable people to inspire their own life. On the basis of inheriting the precious brocade experience left by their ancestors, those Zhuang women who were skillful and diligent in the past constantly created products with the artistic characteristics of their own nation, which gained modern aesthetic significance. For example, by integrating the "Swastika", "life", "beauty" and "fu" into the combination of patterns, these works are the source of their ideals and beliefs, and also the yearning for them to transcend the present and pursue a happy life.

In the investigation of Lao Baozhen, a brocade artist in Xincheng County, Guangxi, As the old man recalled, Leisure season or polder day is the best day for Zhuang brocade bamboo cage machine installation, There are more women at home at this time, The bamboo cage machine installation process requires several women to work together, Women from a neighborhood or a street will come to help, At the same time, we also discussed the brocade skills and the patterns of brocade, Those who are not good at brocade or are weak can also take this opportunity to learn from highly skilled brocade people, Even some women who have just learned to weave brocade and other sisters borrow "flower book" to study and imitate. At the same time, women often pour out their pain and happiness to each other intentionally or unintentionally. In the process of sharing with each other, women often internalize most of their feelings and experiences into their own spiritual psychology, so as to become the reference and model of their future life. In the continuous communication, the female group not only promotes the cultural flow, but also maintains the stability of the culture. In the gap of continuous cultural innovation and loss, the female group will correspondingly maintain a long process for the culture they inherit and create. Such a process can virtually spread and spread the brocade skills and brocade art of the nation, thus promoting the inheritance of the national brocade culture (Fan, & Zheng, 2015, P: 31-35).

From the spread of brocade craft, it can be seen that the inheritance of brocade craft is mainly from mother to female, sister to sister, neighbors teach each other, and village neighbors, to observe and learn from each other. These zhuang girl, most 123 hair with elders learning manual skills, accept zhuang flower folk traditional craft, with the growth of the age, the accumulation of knowledge, technology skills and the improvement of the beauty concept, they in the brocade, inherited the tradition of the older generation, and added new content, everyone's intelligence is both on the basis of collective creation to play, but enrich, improve, enrich the achievements of predecessors, thus has distinct inheritance and variability (Yu, 1992,44-48).

(2) Innovation of brocade patterns

Zhuang brocade The innovation and change of pattern is the first sense of eye, therefore, is the top priority in industrial research and development. Zhuang brocade Traditional patterns are gradually formed under the influence of the Zhuang people's production and life for thousands of years and the religious culture of their nation, and have a certain stability in the traditional farming society. The inheritance of patterns is the same as the inheritance of the craft, which is the communication between the sisters or neighbors. Zhuang brocade Most of the traditional patterns are derived from

flowers, birds, fish, and insects in nature. According to the characteristics of these natural phenomena, the Zhuang people are processed and refined into Zhuang brocade with their bold omission and deformation techniques. The patterns are rich in decoration, although abstract but contain unique Zhuang culture (Fan, 2015, P: 36-39).

(3) The guidance of color proverbs

In history, the Zhuang nationality did not form their own unified writing, and the people mainly relied on oral language to convey information, knowledge and culture. Through face-to-face oral teaching and communication, adults will teach the brocade skills handed down from their ancestors to the next generation without reservation, and the next generation will master the operation procedures of Zhuang brocade skills and experience the connotation of it in repeated memory. A Zhuang folk proverb goes, "Red with green, deep bright flowers look beautiful, shallow dark flowers are not ugly (Chen, 1999, P: 54-55)." The second kind is to rely on the folk customs for inheritance. Zhuang brocade It is inseparable from the marriage customs and other folk customs. When a Zhuang girl is unmarried, she will carefully prepare a dowry for herself. A desired man will give his own elaborate work as a token of affection. When married, the dowry is indispensable. Zhuang brocade It is also related to hezi custom. After a girl has children, the grandmother usually gives Zhuang brocade braces or Zhuang brocade quilts as a gift. People in the festive folk customs in the invisible acceptance and complete the cultural transmission. However, under the background of the general "fading away" of cultural inheritance subjects and the gradual disappearance of folk life scenes, the spontaneous artistic inheritance of Zhuang society cannot be maintained (Qin, 2010, P: 136-137).

Summary

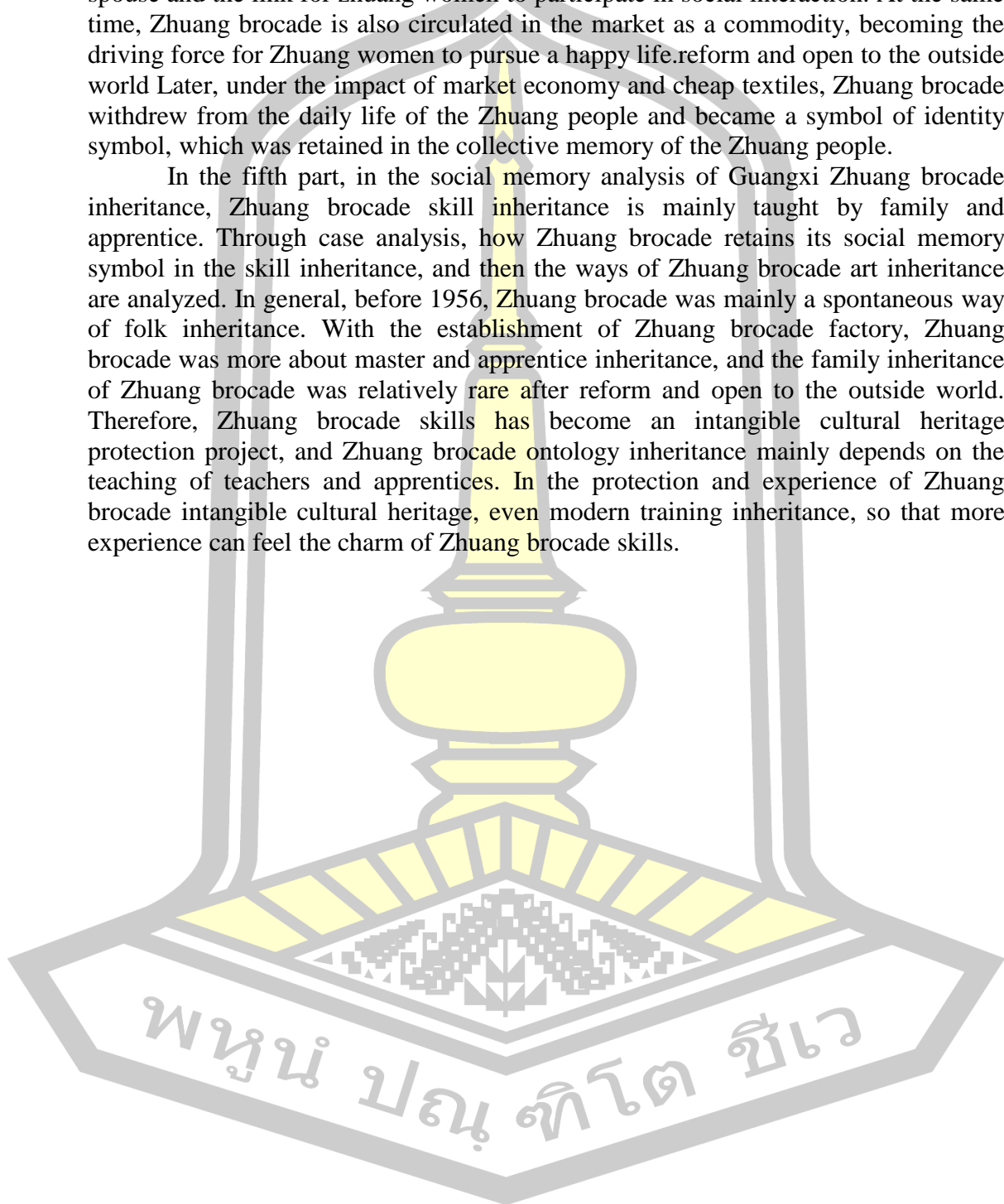
The first part analyzes the Guangxi Zhuang brocade, the social memory in historical documents, and obtains the "Guangxi brocade" in Shu Brocade spectrum, which can not be equivalent to the present Zhuang brocade, it is the predecessor of Zhuang brocade. "Guangxi brocade" was influenced by the art and art form of Tang style and Liao style in the Central Plains, and had an influence on Zhuang brocade. Again, through the literature comparison and the story of the legend, it is concluded that Zhuang brocade was a modern Zhuang brocade under the influence of chieftain and Zhuang culture in the Ming and Qing Dynasties.

In the second part, the totem and belief in Guangxi Zhuang brocade are researched. Zhuang brocade integrates the original totem and polygod belief in the pattern, and Zhuang brocade is closely related to the totem and belief of the Zhuang people, becoming the bond between Zhuang brocade and the totem and belief of the Zhuang people, and Zhuang brocade plays different social memory symbols in various totems and belief ceremonies.

The third part, the Guangxi Zhuang brocade in the important life ceremony social memory analysis, Zhuang brocade is used for the birth of the Zhuang ceremony, rite, wedding and funeral, etc., Zhuang brocade in the life ceremony build the symbol of the affection, the symbol of love, ability and the symbol of the home, in the Zhuang different stages of life Zhuang brocade through life ceremony, become the Zhuang precious memory symbol.

In the fourth part, social memory analysis of Guangxi Zhuang brocade in daily life, Zhuang brocade becomes the courtship symbol and social bond between men and women in Zhuang nationality, which is the condition for zhuang men to choose a spouse and the link for zhuang women to participate in social interaction. At the same time, Zhuang brocade is also circulated in the market as a commodity, becoming the driving force for Zhuang women to pursue a happy life. reform and open to the outside world Later, under the impact of market economy and cheap textiles, Zhuang brocade withdrew from the daily life of the Zhuang people and became a symbol of identity symbol, which was retained in the collective memory of the Zhuang people.

In the fifth part, in the social memory analysis of Guangxi Zhuang brocade inheritance, Zhuang brocade skill inheritance is mainly taught by family and apprentice. Through case analysis, how Zhuang brocade retains its social memory symbol in the skill inheritance, and then the ways of Zhuang brocade art inheritance are analyzed. In general, before 1956, Zhuang brocade was mainly a spontaneous way of folk inheritance. With the establishment of Zhuang brocade factory, Zhuang brocade was more about master and apprentice inheritance, and the family inheritance of Zhuang brocade was relatively rare after reform and open to the outside world. Therefore, Zhuang brocade skills has become an intangible cultural heritage protection project, and Zhuang brocade ontology inheritance mainly depends on the teaching of teachers and apprentices. In the protection and experience of Zhuang brocade intangible cultural heritage, even modern training inheritance, so that more experience can feel the charm of Zhuang brocade skills.



CHAPTER IV

Guangxi Zhuang brocade "traditional invention" in China reform and open to the outside world process

This chapter answers to the third research goal. The third study objective is to study and analyze the "traditional invention" of Guangxi Zhuang Brocade after the reform and opening up. The concept used in this chapter is "traditional invention". This chapter mainly discusses the process of Zhuang brocade in 2023, which is divided into five sections. The first part is the government shaping the zhuang cultural symbol Guangxi Zhuang brocade analysis; The second part is the creation of giant Zhuang brocade and the influence of — Guangxi Zhuang brocade shaping into the invention of zhuang cultural symbols; The third part is the invention and analysis of Guangxi Zhuang brocade production technology; The fourth part is divided into Guangxi Zhuang brocade pattern and pattern of the invention of the analysis; Part V Guangxi Zhuang brocade "traditional invention" Practice Exploration (Figure 38).

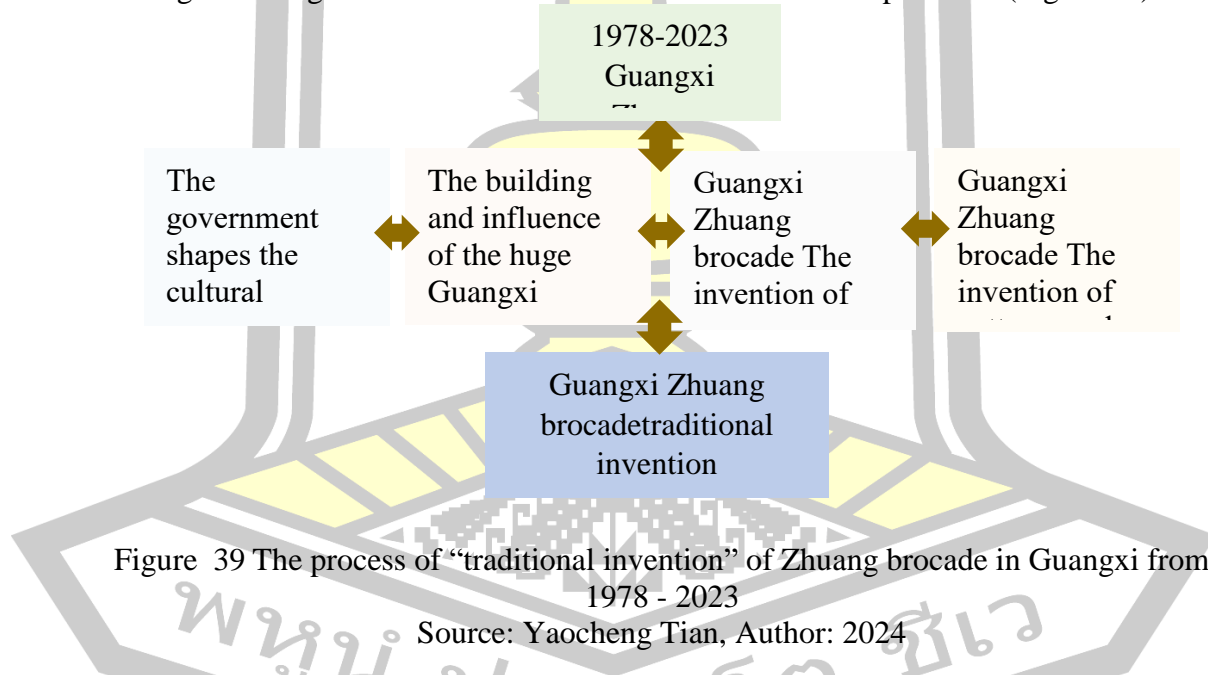


Figure 39 The process of "traditional invention" of Zhuang brocade in Guangxi from 1978 - 2023

Source: Yaocheng Tian, Author: 2024

In the deepening of China's reform and open to the outside world, under the impact of market economy and industrial commodities, the social life of the Zhuang people has undergone remarkable changes. In the process of this reform, it is inevitably impacted, and the Zhuang "tradition", which is often closely connected with it, is also innovating and inven. The fine and inexpensive industrial textiles quickly occupied all levels of the Zhuang society in Guangxi, and had a revolutionary influence on the original living soil and the zhuang traditional customs of Zhuang brocade. After 2006, driven by the dual forces of the government and the people,

Guangxi Zhuang brocade entered a period of reform and completely opened the process of "traditional invention" of Zhuang brocade.

First of all, through the implementation of policy support, the government has set up a national Zhuang brocade technology intangible cultural heritage protection project, in order to increase its inheritance and protection efforts. Secondly, the government actively guided Zhuang brocade enterprises to innovate, invented the giant Zhuang brocade, and successfully applied for the Guinness Record of the largest Zhuang brocade, which further enhanced the brand influence and market competitiveness of Zhuang brocade. Thirdly, in order to meet the needs of the development of The Times, the Guangxi Zhuang brocade technology has been deeply improved and innovated, including the innovation of Zhuang brocade patterns and patterns, to meet the modern aesthetic needs. This series of innovative measures have effectively stimulated Zhuang brocade's ability to survive and develop in the modern urban environment.

In addition, in order to further expand the living space and market of Zhuang brocade, we put forward the integration of Guangxi Zhuang brocade and other folk activities. By holding various folk activities with Guangxi characteristics, Zhuang brocade will become the carrier and disseminator of Zhuang culture and further promote its inheritance and development. It should be emphasized that the Zhuang brocade "traditional invention" process is not accomplished overnight, but a continuous process of exploration and innovation.

Finally, in the new era background, with the joint efforts of the government and civil forces, Guangxi Zhuang brocade has successfully adapted to the new living environment, and has been reshaped with new uses, images and cultural connotations. This fully demonstrates the strong vitality and cultural value of Guangxi Zhuang brocade, and also provides valuable experience and inspiration for the inheritance and development of intangible cultural heritage.

Part I: The analysis of the government in shaping the zhuang cultural symbol

Guangxi Zhuang brocade

This section analyzes the analysis of the zhuang cultural symbol Guangxi Zhuang brocade. It is divided into three parts: the first is the government policy influence on Guangxi Zhuang brocade and the development of Guangxi Zhuang brocade manufacturers; the second is the government on Guangxi Zhuang brocade, intangible cultural heritage, protection, and the third is the government policy guidance analysis on shaping Guangxi Zhuang brocade culture.

Since the implementation of the reform and open to the outside world in 1978, China's politics and economy have developed vigorously, and many contradictions have emerged between the people's ever-growing material life and their backward productive forces. Guangxi Zhuang brocade As one of the representatives of the excellent traditional arts and crafts of the Chinese nation, it is an important part of the Zhuang folk culture, and also the key to understanding the continuity and integrity of the Zhuang culture (Chen, 2018, P: 82-83). Therefore, the government has two stages in shaping the Guangxi Zhuang brocade cultural symbols. The first phase was from 1978- -2006, The government shaped the Guangxi Zhuang brocade mainly from the technical support, brand recommendation and soft culture packaging; The second phase is from 2006- -2023, Guangxi Zhuang brocade Skills become a national

intangible culture after childbirth, Policy support was increased, Expand the influence of shaping the cultural brand, Promote the combination of Guangxi Zhuang brocade and strong with Zhuang traditional festivals in folk activities, For example, mutual cooperation in the national intangible cultural heritage "March 3rd of the Zhuang Nationality" activities, Successfully shaping Guangxi Zhuang brocade has become one of the symbols of Zhuang culture.

1.1 Impact of government policy on Guangxi Zhuang brocade and the development of Guangxi Zhuang brocade manufacturers

(1) Impact of government policy on the Guangxi Zhuang brocade

Since the implementation of the reform and open to the outside world policy in 1978, the government of Guangxi Zhuang Autonomous Region has actively promoted Guangxi Zhuang brocade to the world stage to strengthen exchanges between ethnic culture and international community. For example, in 1985, imitations of tribute Zhuang brocade from the Qing Dynasty were sent to Japan for exhibition, showing the unique charm of Zhuang brocade art. Subsequently, Zhuang brocade was selected to become a special product in the major national activities, among which Zhuang brocade "eight feng Chaoyang wall hanging" was selected as the special gift of the opening ceremony of the Beibrocadedeg Asian Games. In the two national Ethnic Games in 1991 and 1995, Zhuang brocade products such as backpacks, file bags and gifts were also favored, becoming an important carrier to display ethnic culture. Although these measures have promoted the development of Zhuang brocade real industry to some extent, with the rapid growth of market economy, Zhuang brocade production has gradually faced labor, time consuming and low productivity, leading to being gradually eliminated by the market in the late 1990s. Since the beginning of the 21st century, the national and autonomous region governments have issued a series of relevant policies for the protection of Zhuang brocade, aiming to strengthen the protection and inheritance of its cultural heritage.

National level: Since 2003, China has launched the protection project of Chinese ethnic and folk culture, and has successively issued a series of laws and regulations and measures to provide sufficient guarantee. In May 2006, the Ministry of Culture published a list of 518 national intangible cultural heritage items, and then held the first national "Cultural Heritage Day" on June 10 (Wu, 2011, P: 259-265). In 2011, The State issued the Intangible Cultural Heritage Law of the People's Republic of China; In 2012, The Ministry of Culture issued the Guiding Opinions on Strengthening the Productive Protection of Intangible Cultural Heritage for Industrial Development; In 2017, The General Office of the CPC Central Committee and The General Office of the State Council issued the Opinions on Implementing the Project of Inheritance and Development of Excellent Traditional Chinese Culture; According to the Revitalization Plan of Chinese Traditional Crafts, released in 2017, To revitalize traditional crafts, Help to inherit and develop the fine traditional Chinese culture, To conserve the cultural ecology, Rich in cultural resources, Enhance cultural confidence; Help to better develop the creativity of manual labor, To cultivate and promote the craftsman spirit of excellence in the whole society; Helps to promote employment, Targeted poverty alleviation, Increase the income of both urban and rural residents, Enhance the vitality of traditional street blocks and villages (Huang, 2023, P:15-18). In April 2018, culture and tourism, intangible cultural heritage department as internal institutions, to perform "formulate non-material cultural

heritage protection policy and planning and organize the implementation, the organization to carry out the intangible cultural heritage protection work, guide the intangible cultural heritage investigation, record, confirm and establish list, organization non-material cultural heritage research, propaganda and dissemination of work" responsibility. Especially under The General Office of the State Council, text brigade department issued the State Council general office on promoting the development of global tourism guidance "about promoting the sustainable development of rural tourism guidance" "national cultural ecological reserve management method" on the revitalization of traditional craft in poor areas power precision notice for poverty alleviation, policy implementation for local government organizations the genetic carrier to declare all kinds of projects provides the basis, also promote enterprises to inject fresh blood into the national industry. Zhuang brocade Although it was developed from a family workshop, production is the only driving force to promote the development of craftsmanship.

Autonomous region level: Guangxi Zhuang Autonomous Region has issued a number of policy support documents. Since April 1, 2005, the Regulations of Guangxi Zhuang Autonomous Region on Protecting Traditional Ethnic Folk Culture were implemented; on December 19, 2010, the Implementation Opinions on Accelerating the Development of Cultural Industry were once again issued. Subsequently, on May 22, 2011, the "12th Five-Year" Plan for the Development of the Cultural Industry in Guangxi Zhuang Autonomous Region was released, which further established the key strategic position of the arts and crafts industry in the economic development. In addition, the Regulations of the Guangxi Zhuang Autonomous Region on the Protection of Intangible Cultural Heritage was promulgated in 2017. By May 11, 2022, the General Office of the CPC Central Committee of the Autonomous Region and the General Office of the People's Government of the Autonomous Region jointly issued the Notice of the Implementation Opinions on Further Strengthening the Protection of The Intangible Cultural Heritage in Guangxi. At the same time, when formulating cultural industry planning, all cities and regions should pay attention to and promote the development of arts and crafts industry with regional characteristics, so as to ensure that the arts and crafts industry can coordinate with other key cultural industries (Liang & Zheng, 2012, P: 19).

Since Guangxi Zhuang brocade became a national intangible culture, postpartum, Its use has been newly changed, And, driven by the new production technology, And under the dual role of the demand for government services, Zhuang brocade Achieved significant innovation in patterns and product forms, Zhuang brocade With the creation of "giant Zhuang brocade", Rereshaped Zhuang brocade's cultural brand image, Make it become a symbol of the new culture "ritual" in the foreign exchange of Guangxi Zhuang nationality and Guangxi government.

In 2007, to commemorate the 10th anniversary of Hong Kong's return to the motherland, the government of Guangxi Zhuang Autonomous Region presented "Celebrating the 10th Anniversary of Hong Kong" as a gift. In 2010, the Zhuang brocade Zhuang brocade was displayed in the Shanghai World Expo, which was not only permanently collected, but also won the title of "the largest Zhuang brocade" in the Guinness World. With the continued holding of the ASEAN Expo in Nanning, Guangxi Zhuang brocade, with its unique artistic charm and profound cultural connotation, has been repeatedly selected by the government as a gift for important

activities, showing the unique style of Guangxi and Zhuang ethnic culture. In 2021, in order to celebrate the 100th anniversary of the founding of the Communist Party of China, the twelve weaver women in Banchi Village, Shuangmeng Village, brocadelong Town, Longzhou County, created the long scroll of Beautiful Zhuang brocade Zhuang brocade, in order to offer sincere blessings to the centennial birthday of the Party.

In addition, in 2019, during the 70th anniversary of the founding of the People's Republic of China, in order to celebrate the grand celebration, organized by the Guangxi Zhuang autonomous region government "grandeur" in Guangxi float activities, from two levels using Zhuang brocade, one is the Zhuang brocade cloth, to participate in the "grandeur" Guangxi float parade actors design series clothing with national characteristics, the national characteristics of clothing not only shows the rich national culture and unique regional amorous feelings, also added a different style for the celebration. Second, Zhuang brocade patterns are also widely used in the decoration of stepping on cars, especially the blue Zhuang brocade patterns in the front of the float, which highlights the diversity of Zhuang brocade culture used in modern society. The "Magnificent Guangxi" float of this event is the image of Guangxi and the image of the Zhuang nationality displayed to the people of the whole country and even the world. Therefore, Guangxi Zhuang brocade continues to expand its living space in different occasions and activities to show its tenacious cultural vitality (Figure 39).



Figure 40 Guangxi float actors dressed in ethnic costumes take pictures in front of the mass parade marking the 70th anniversary of the founding of the People's Republic of China in 2019

Source: <https://www.163.com/dy/article/H2K6Q8J10516IU5Q.html> 17/January/2024

To sum up, with the deepening of reform and open to the outside world, under the high attention and support of the government, Guangxi Zhuang brocade has been re-endowed with the connotation of new culture and the significance of The Times through the display and use on various major occasions, and has become one of the important symbols of Zhuang culture.

(2) The development of Guangxi Zhuang brocade manufacturers

First, Guangxi Zhuang brocade state-owned enterprises

Since 1949, under the guidance of the party's ethnic policy, Zhuang brocade production has been showing new vitality. In 1954, the Chinese government took active measures to promote the old artists in Zhuang brocade production core areas, such as Xincheng, brocadexi, Binyang, Rongshui and other counties to revive traditional crafts, establish Zhuang brocade production cooperatives, realize professional production, and get key support from the government. In addition, many urban streets and rural people's communes have also set up Zhuang brocade production cooperatives or groups, expanding the ranks of brocade art artists. As time went on, the original cooperative gradually expanded and evolved into a professional Zhuang brocade manufacturer. In 1987, the Chinese government injected a total of more than 1.7 million yuan into the four brocade weaving factories, built 8,000 square meters of factories, and introduced semi-mechanized equipment to replace the traditional "bamboo cage machine". After the 1990s, the Zhuang brocade gradually went into decline. Many artists, in the zhuang brocade in the original crisis, or please go, or automatically go out to make a living; the brocade industry is increasingly depressed, the township enterprises in inadvertently stop production, the county brocade factory also quietly closed the door. As the origin of Zhuang brocade in northern Guangxi, Xincheng Zhuang brocade Factory closed down in 2006. At the beginning of liberation in Guangxi, only brocadexi Zhuang brocade Factory and Binyang National Brocade Factory have survived (Zhang, 2010, P: 123-124).

Guangxi Institute of Arts and Crafts, formally established in 1960, is positioned as the only minority arts and crafts research institution in Guangxi. At present, the institute gathers a large number of scientific research and technical personnel and folk craftsmen, and is the largest and most powerful Zhuang brocade research, design, development and production base in China. Since 1960, the institute has been committed to protecting and inheriting the Zhuang brocade process, which is on the verge of extinction, and actively cultivating folk brocade talents to ensure the inheritance of this unique skill. The institute has made remarkable achievements in Zhuang brocade product development and quality improvement. Zhuang brocade The bag has been used as a special file bag for representatives of participating countries, and has been designated as a special product in the National Ethnic Minority Games and the 50th anniversary of the founding of Guangxi Zhuang Autonomous Region.

Until 2004, the government of the autonomous region has allocated more than 7 million yuan to establish a Zhuang brocade research and development base in Guangxi Institute of Arts and Crafts, becoming the most powerful enterprise in Zhuang brocade research and development and production in China. The institute recruits more than 20 scattered folk brocade craft masters and inheritors, to carry out Zhuang brocade weaving, product development, and cultivate new talents of brocade craft. At the same time, a series of project research on "replication and development

of Guangxi cultural relics brocade" was carried out, and the introduction of folk artists, enterprise management and professional and technical personnel was increased. Through CAD computer aided design system, electronic pattern output technology and mechanical pattern wear, the Zhuang brocade weaving equipment is updated and transformed to greatly improve the efficiency of brocade process, shorten the product development cycle, and enrich the Guangxi tourism handicraft market with Guangxi ethnic characteristics (Wu, 2014, P: 162).

In order to further promote the sustainable development of Guangxi arts and crafts industry, Guangxi Tourism Development Group established Guangxi Arts and Crafts Research Institute Co., Ltd. on July 10, 2019. While assuming the major responsibility, the company is committed to leading the industry standards, formulating the "Guangxi Zhuang brocade Product Enterprise Standard", and completing the official filing in the Nanning Municipal Bureau of Quality and Technical Supervision. This move not only makes up for the lack of unified standards in the field of national brocade in Guangxi, but also lays a solid foundation for the technological innovation, product structure optimization and the inheritance and development of Guangxi Zhuang brocade culture in the Zhuang brocade weaving industry.

In addition, the institute has also cooperated with Guangxi University of the Arts to jointly develop and design a series of costumes called "Magnificent brocadeyi". This series of clothing cleverly deconstructs and reorganize the traditional elements of Zhuang brocade, and combines them with modern aesthetic concepts and fashion trends, showing a unique artistic charm. Since its launch, this series of clothing has been widely loved by consumers and won awards on many occasions, injecting new vitality into the cause of the arts and crafts in Guangxi.

Second, the Guangxi Zhuang brocade non-genetic inheritance workshop

Binyang County Xiangguang Brocade Square. Founded in 2002 by Ms. Tan Xiangguang, a master of Chinese arts and crafts, she focuses on the inheritance, sorting and development of traditional Zhuang brocade technology. The brocade workshop insists on the "bamboo cage machine" pure handmade as the core, cleverly integrating modern design elements, to create both decorative and practical Zhuang brocade product series. Ms. Tan Xiangguang is enthusiastic about public welfare, teaching Zhuang brocade weaving skills for free, and providing bamboo cage loom, to encourage more family women to devote themselves to the cause of brocade, so as to effectively promote the intergenerational inheritance of brocade skills. Xiangguang Brocade Square has a variety of product lines, including handmade ethnic brocade wall hanging, Guangxi Zhuang brocade ethnic bags, fine decorative fabrics, as well as a series of ethnic brocade products such as scarf, shawl, bed flag, seat cushion, pillow, business card clip and tie clip. In addition, the launch of "Tan Xiangguang" brand series of products, aiming to meet the diversified needs of different consumers (Figure 40).



Figure 41 Xincheng County doctor Zhuang brocade brocade skills display
Source: Yang Na was shot in Xiangguang Brocade Square, Binyang County 17 /
October / 2023

Xincheng Doctor Zhuang brocade brocade Art Base was established in Xincheng County Government in 2010, aiming to support brocade artists and promote the inheritance and development of Xincheng Zhuang brocade. This base shoulders the heavy responsibility, committed to the inheritance and promotion of Zhuang brocade culture and art in Guangxi, focusing on the protection of Xincheng Zhuang brocade culture and its unique patterns. To this end, the base set up Xincheng Zhuang brocade training institute, to provide local residents with ethnic minority Zhuang brocade weaving skills courses, covering Guangxi toast handicraft Zhuang brocade, embroidery and hydrangea skills, etc., but also to provide tourists with Xincheng Zhuang brocade skills experience activities (Figure 41). At present, the representative works of Doctor Xincheng Zhuang brocade brocade art base include Zhuang brocade series swastika pattern, diamond pattern, Zhuang brocade hydrangea and other exquisite handicrafts. In addition, when visiting, tourists can not only experience the unique charm of Xincheng Zhuang brocade brocade skills, but also have the opportunity to buy all kinds of tourism and cultural commodities made by Xincheng Zhuang brocade, so as to have a deeper understanding and feel the charm of this traditional art.



Figure 42 Xincheng County doctor Zhuang brocade brocade skills display
Source : <https://baijiahao.baidu.com> 17/January/2024

Longzhou Zhuang brocade Art Workshop. In 2016, Guangxi brocade Zhuang brocade Culture and Art Co., Ltd., together with Guangxi Zhuang Autonomous Region Museum, Guangxi Embroidery Development Research Association and other institutions, jointly established Longzhou Zhuang brocade Art Workshop. The workshop is located in Longzhou, Guangxi and other places, set up production bases, and carried out brocade skills training class. Working closely together with the local government departments, we have successfully attracted the poor households and the left-behind women to participate in the free training. After professional training, the students have mastered the traditional brocade pattern techniques and are able to produce exquisite Zhuang brocade products. These products are responsible for repurchase, processing and marketing by the main creative organization, which has effectively promoted the development of the local economy and brought stable economic income to the participants. The successful operation of Longzhou Zhuang brocade Workshop not only achieves a win-win situation between social and economic benefits, but also as a model of cross-field and cross-regional integrated development of Zhuang brocade industry, providing a new path for the inheritance and development of traditional handicrafts. With its outstanding contribution and extensive influence, Longzhou Zhuang brocade Skills Workshop was highly recognized by the Ministry of Culture and Tourism and the Poverty Alleviation Office of The State Council in July 2018, and was listed as one of the first "Intangible Cultural Heritage + Poverty Alleviation" employment workshops in China, becoming the leader in the industry.

Third, Guangxi Zhuang brocade private companies

Guangxi brocade Zhuang brocade Culture and Art Co., Ltd. Founded in February 2004, it has always been committed to becoming a model of innovative development of Guangxi Zhuang brocade industry. The company is deeply engaged in the inheritance of local national culture, integrating research and development, planning, design, production, sales, exhibition, cultural exchange and performing arts

and other diversified businesses, and successfully shaped the "gold Zhuang brocade", "Guangxi embroidery", "Zhuang Tai", "gold hydr" and other well-known brands. Under the efficient and professional modern enterprise management, brocade Zhuang brocade Company has successfully created a unique and charming brand image by virtue of the planning and execution of characteristic works and folk custom activities. Its products not only sell well in Southeast Asia and European and American markets, the company has become a private enterprise very representative of the national culture in Guangxi. In order to further promote the national brand, Kim Zhuang brocade company set up the Sino-Italian Cultural Design Center in Italy in 2019, and registered the Guangxi Zhuang brocade Cultural Promotion Association in Rome. In addition, the company has also registered national brands in Europe and China, and set up production and processing bases abroad, successfully introduced Zhuang brocade products into the European market, and won the high recognition of European sellers and brand owners.

Guangxi Zhuang brocade Shanhe Culture Development Co., Ltd., In recent years, actively implementing the development model of "government + company + base + farmers + market", By systematically promoting protection, inheritance, research and development, design, production, display, marketing, promotion and other closely linked measures, Successfully extended the Guangxi Zhuang brocade industrial chain, Gather your strength, Creating the scale effect of brocade culture, It has provided strong support for the creative transformation and innovative development of Guangxi Zhuang brocade intangible cultural heritage resources.

Fourth, non-profit Guangxi Zhuang brocade industry-university-research institutions

Since 2006, Guangxi Zhuang brocade has achieved remarkable results in cross-border integration. Through continuous deepening development, the quality and efficiency of the Zhuang brocade industry have been effectively improved. In order to further promote the integration of industry, university and research, Tan Xiangguang, a national master of Zhuang brocade arts and crafts, and Nanning Vocational and Technical College cooperated to jointly create "Tan Xiangguang Studio", innovated the school-enterprise cooperation mode, and injected new vitality into the cultivation of Zhuang brocade talents and industrial development. These measures make Zhuang brocade intangible cultural heritage deeply rooted in the hearts of the people, let students personally experience the charm of national culture in class, and then stimulate endless creative inspiration, and inject new vitality into the inheritance of traditional national skills. At the same time, enterprise manufacturers and universities in Guangxi also actively participate in the innovative design of Zhuang brocade clothing and cultural and creative products.

1.2 The government protects Guangxi Zhuang brocade and intangible cultural heritage

Since China officially became the UNESCO Convention on the Protection of Intangible Cultural Heritage in 2004, China's cultural heritage research community has always attached great importance to the protection and development of intangible cultural heritage. In particular, in the Guangxi Zhuang Autonomous Region, at the 13th session of the Standing Committee of the Tenth People's Congress held on April 1, 2005, the Regulations of the Guangxi Zhuang Autonomous Region on the Protection of Traditional Ethnic and Folk Culture were unanimously adopted. This

landmark regulation provides a solid legal cornerstone for the protection of intangible cultural heritage. With such a strong policy guidance and the joint promotion of cultural and tourism undertakings, Zhuang brocade, a precious intangible cultural heritage, has been effectively protected and rationally developed and utilized.

(1) Guangxi Zhuang brocade National intangible cultural heritage protection

In 2006, the "Zhuang brocade technique" declared by brocadegxi County of Guangxi Zhuang Autonomous Region was listed in the first batch of national intangible Cultural Heritage list (Figure 42). Zhuang brocade It has a long history. The "spot cloth" woven by the Zhuang ancestors in the Han Dynasty is its predecessor. After the founding of the People's Republic of China, archaeologists excavated several pieces of orange brocade in the No.7 burial pit of the Han Tomb in Luopo Bay, Guangxi, confirming that the brocade skills in Guangxi in the Han Dynasty. Zhuang brocade Skills was formed in the Tang and Song Dynasties, further developed in the Ming and Qing Dynasties, and listed as tribute in the Ming Dynasty. In the late Qing Dynasty and the early Republic of China, Zhuang brocade began to decline. After more than a thousand years of development, Zhuang brocade has three types of its own system, more than 20 varieties and more than 50 kinds of patterns. It is famous for its strong and durable, exquisite skills, unique patterns and exquisite patterns. Zhuang brocade Is one of the excellent cultural heritages of the Zhuang nationality. It can not only provide vivid physical materials for the research of the textile skills of ethnic minorities in China, but also add living examples to the textile history of China and even the world, which plays a positive role in inheriting and carrying forward national culture and enhancing national self-esteem. However, due to various reasons such as history and reality, Zhuang brocade is facing a severe inheritance crisis and is in urgent need of rescue and protection (Zhou, 2006, P: 884).



Figure 43 National intangible cultural heritage —— Zhuang brocade technical plaque
Source: Yaocheng Tian was taken in brocadegxi National Intangible Cultural Heritage Exhibition Hall 7 / July / 2023

Hobsbaum confirmed in traditional invention: " The 'tradition of being invented' necessarily implies continuity with the past. In fact, they often try to connect with an appropriate and historic past " (Eric & Terence, 2020, P: 6). Zhuang brocade As the choice of the application project, the reasons are as follows: First, Zhuang brocade not only carries a long history and unique national technology, but also has the symbolic capital of dignity and fame because of the "tribute" of the royal family. The high popularity of this symbol endows it with profound symbolic significance and occupies an irreplaceable position in the Zhuang culture. Secondly, Zhuang brocade, as a traditional ethnic cultural resource that can be used locally, has both "economic benefits" and "social benefits", showing great potential for shaping local image and promoting local economic development. These factors have been fully demonstrated in the Zhuang brocade project declaration, and have become the key to the success of its declaration.

(2) Guangxi Zhuang brocade Autonomous region-level intangible cultural heritage protection

In May 2006, brocadegxi Zhuang brocade art was included in the first batch of national intangible cultural heritage list, marking a new stage in the development of Zhuang brocade and the "traditional invention" process. In May 2010, in the third batch of intangible cultural heritage projects of Guangxi Zhuang Autonomous Region, it added the first batch of Xincheng Zhuang brocade skills and Binyang brocade skills, and expanded the protection scope and support of Zhuang brocade skills. In December 2018, the Golden Dragon Zhuang brocade art in Longzhou County was included in the seventh batch of representative items of intangible cultural heritage at the autonomous region level.

In addition, the government of Guangxi Zhuang Autonomous Region has also carried out the identification of inheritors of Guangxi Zhuang brocade intangible cultural heritage. In 2010, Ms.Tan Xiangguang was identified as the representative inheritor of Binyang brocade in Guangxi Zhuang Autonomous Region; in 2018, Ms.Li Suying was identified as the representative inheritor of brocadelong Zhuang brocade in Longzhou County of Guangxi Zhuang Autonomous Region; in 2021, Mr.Lan Peiwen was identified as the representative inheritor of Xincheng Zhuang brocade of Guangxi Zhuang Autonomous Region. The establishment of these inheritors is not only an affirmation of their personal skills, but also provides a solid guarantee for the inheritance and development of the Zhuang brocade skills (Table 12).

พหุ ม ประ โท ชี เว

rank	Project category	name	Project application area or unit	Project protection unit	inheritor	Release time
National intangible cultural heritage	traditional skill	Zhuang brocade weaving skills	brocadegxi Cultural Center	brocadegxi City Zhuang brocade factory	Li village spirit	2006 (first batch)
District-level intangible cultural heritage expansion	traditional skill	Xincheng Zhuang nationality brocade skills	Xincheng County	Xincheng County Cultural Center	Lampeven	In 2010 (the third batch)
		Binyang brocade skills	Binyang County	Binyang County Cultural Center	Tan Xiangguang	In 2010 (the third batch)
		Longzhou Golden Dragon Zhuang brocade skills	Longzhou County	Longzhou County Cultural Center	Li Suying	In 2018, (7th batch)

Table 11 Zhuang brocade art national and district level intangible cultural heritage protection Source: Yaocheng Tian, Author: 17/January/2024

1.3 analysis of the government's policy guidance on shaping Guangxi Zhuang brocade culture

(1) The creation of Zhuang brocade culture in a Picture of Zhuang brocade "A Zhuang brocade" is a folklore derived from the Zhuang nationality. By telling the persistent pursuit of happiness, it vividly shows the unique national image of the Zhuang people and deeply interprets the unique connotation of Zhuang brocade culture. After the founding of new China, the state implemented a new ethnic policy to respect and protect the culture of ethnic minorities. In 1952, Xiao Ganniu recorded the story of "A Zhuang brocade" told by farmer Huang Yonghe in Greenland Village, Chengxiang Town, Laibin County, which was widely spread in Guangxi. Then, in 1955, a Zhuang brocade was published in the first issue of the national journal Folk Literature (Xiao, 1955, P: 18-21), which made the image of the Zhuang nationality move from Guangxi to the whole country for the first time, and Zhuang brocade became a symbol of the Zhuang culture known to the national people. This event marks the official opening of a new chapter in Zhuang brocade culture communication. In 1958, with the establishment of Guangxi Zhuang Autonomous Region, a new form of Zhuang brocade story appeared. The Zhuang brocade was adapted by Li Yin, Xiao Ganniu and Zhou Minzhen as a tribute play established by Guangxi Zhuang Autonomous Region (Xiao, 1958, P: 1-46), which is the first Zhuang

brocade culture became a symbol of Zhuang cultural identity. Therefore, Zhuang brocade has also become one of the image symbols of the Zhuang people.

Subsequently, in September 1959, Guangxi Opera Troupe "A Zhuang brocade" and "Peach Blossom Fan" by Guangxi Opera Troupe were performed in Beibrocadedg (Wang, 1984, P: 28). In the same year, Shanghai Beauty Film Factory produced cartoons and distributed them throughout the country (Wang & Peng, J, 2019, P: 119). In addition, the story of a Zhuang brocade went abroad and was translated into various languages. The Japanese Zhuang brocade translated by Junashima was included in the Japanese primary school Chinese textbook (Cheng, 1981, P: 159-160); in 1958, the Foreign Language Press also published a Russian version of the comic book. In 1960, "A Zhuang brocade" won the honorary award of the 12th Karlovy International Film Festival. A Zhuang brocade plays a vital role in the image and cultural communication of the Zhuang people. Its wide spread is closely linked to the great importance attached to the literature and art of ethnic minorities after the founding of new China. At the same time, as an easy to understand text, the work is also deeply loved by the public and meets a wide range of aesthetic needs (Mao, 2020, P: 58-62).

Reform and open to the outside world Later, in July 1980, the story of a Zhuang brocade was readapted by Li Yin, and he participated in the ethnic minority art performance in Guangxi Zhuang Autonomous Region. As a folk story of the Zhuang nationality, a Zhuang brocade skillfully integrates rich cultural elements of the Zhuang nationality, including costume culture, dry-style architecture, totem worship and unique folk customs and festivals. With Zhuang brocade as the main line, it vividly shows the unique charm of the Zhuang nationality culture. This work is not only easy to understand, but has won a wide mass base in the course of thousands of years. It has successfully retained the distinctive characteristics and ethnic characteristics of the Zhuang culture, and deeply expressed the Zhuang people's yearning for a better and happy life. Therefore, "A Zhuang brocade" is not only a cultural symbol of Guangxi Zhuang Autonomous Region, but also an important link to strengthen the cultural identity of the Zhuang people. Carrying forward the Chinese folk culture tradition represented by this work is of profound social significance for enhancing our sense of identity to our own national culture and enhancing the cohesion of the Chinese nation (Wang & Peng, J, 2019, P: 119). It shows that a Zhuang brocade spreads across different literary types and media, which not only successfully retains the folk stories of the Zhuang people, but also makes these stories widely spread. In this communication process, its connotation transcends the boundaries of nationality and region, and shows a broader cultural influence.

(2) Creation of Zhuang brocade cultural symbols in music

The Zhuang nationality is a nation who loves singing. Their songs and Zhuang brocade are all derived from the daily life of the Zhuang nationality. Therefore, under the common cultural background, the Zhuang people have created a large number of touching songs with the theme of Zhuang brocade, which have been sung today, and some of them are still widely spread throughout the country. For example, the Zhuang brocade to Chairman MAO in 1965, In Zhuang brocade, 1996, "A Beautiful Zhuang brocade" in 1999, The Zhuang brocade on the Dragon's Ridge, 2003, The Zhuang brocade, 2007, In The Zhuang brocade, 2010, In The Heart of Zhuang brocade, 2012, In "Zhuang brocade" in 2013, And 2014's "Zhuang brocade Hanging on the Horizon"

and "Zhuang brocade." These songs fully show the profound heritage and unique charm of Zhuang brocade culture. Among them, "Zhuang brocade to Chairman MAO" is a chorus song composed by Gao Shouxin and Luo brocade of the Central National Song and Dance Troupe and composed by Mtin. It was written in 1965 to celebrate the founding of Guangxi Zhuang Autonomous Region. This song has been handed down since the 1960s and has become a Zhuang folk song with national influence. The song is adapted based on the "yang Diao" folk song in western Guangxi. It adopts the cheerful and warm rhythm and the unique ring tone of Zhuang folk song, as well as the high melody of pure four degrees. The lyrics express the Zhuang people to dedicate the beautiful Zhuang brocade to Chairman MAO, in order to offer their heart, but also show the new look of Zhuang Xiang. This song not only strengthens the function of Zhuang brocade as a traditional gift, but also directly links Zhuang brocade with the leaders, truly depicting the joy of Zhuang people to welcome Chairman Mao's arrival for the first time. In addition, the song also reflects that Zhuang brocade has become a symbol of the Zhuang people, showing the remarkable achievements of the social development of Guangzhou west longitude and the earth-shaking changes in the land of Bagui, and expressing the joy of the people living a happy life. After entering reform and open to the outside world, under the influence of the song "Zhuang brocade to Chairman MAO", the music works closely related to Zhuang brocade after reform and open to the outside world ushered in a golden period of rapid development. Through continuous creation and dissemination, Zhuang brocade has gradually become the cultural symbol of the Zhuang people and the Guangxi region.

(3) Creation of Zhuang brocade cultural symbols in opera

Guangxi Zhuang brocade Culture as a unique folk culture resource, local governments also began to pay attention to the excavation and development and utilization of Zhuang brocade culture. It not only effectively carries forward the traditional culture of the Zhuang nationality, shows the local cultural charm to the outside world, but also can bring certain economic benefits and improve the construction of local social public order and good customs. In November 2008, the Baise government to celebrate the 50th anniversary of the founding of Guangxi Zhuang autonomous region as an opportunity to invite famous playwright Chang Jianjun, Hu Hongyi elaborate screenwriter, famous director Zhang sheng large minority musical drama "Zhuang brocade" successful premiere in Baise (brocade & Wang, 2014, P: 125-126), the play won the "mandarin excellent play award" (Yi, 2010). Therefore, the local government has created the Zhuang brocade opera into a new name card of Zhuang ethnic culture, and displayed the rich, colorful and ancient and mysterious ethnic traditional culture of Guangxi through outsiders, especially people who know little about Guangxi. In the drama Zhuang brocade, Guangxi Zhuang brocade is shaped as the source of happiness for the modern Zhuang people, just as the classic song in the Zhuang opera Zhuang brocade:

Zhuang brocade It is the strong man spring planting and autumn harvest,
 Zhuang brocade Is the strong family of heaven,
 Zhuang brocade It is amama's weaving,
 Zhuang brocade It is the source of happiness pursued by their children.

Under the leadership of the government, Guangxi Zhuang brocade breaks through the shackles of the body, which is no longer a piece of cloth or a bag, but a

concentrated embodiment of the outstanding spirit and quality of the Zhuang people in Guangxi. "Those 'traditions' that appear or claim to be ancient are often come fairly late and are sometimes invented." (Eric & Terence, 2020, P: 1) The government officially sets up the new "traditional" content of Guangxi Zhuang brocade through opera forms, so as to shape Guangxi Zhuang brocade culture into the need of the development of modern society and market economy. It is under this impetus that Guangxi Zhuang brocade quickly established the new "tradition" of Guangxi Zhuang brocade in a short period of time and under the impetus of external formal forces.

Therefore, the transformation process of Guangxi Zhuang brocade from material entity to cultural form highlights the unique charm of Guangxi Zhuang brocade culture. The different lifestyles displayed by its unique cultural characteristics have attracted wide attention and interest, and may even win global attention. This transformation is of great significance for promoting the development of the local tourism industry and injecting new vitality into the local economy and society. Guangxi Zhuang brocade As a living fossil of national culture, it is gradually becoming a valuable cultural resource to promote the development of ethnic regions and society. However, when these cultures are separated from the original context and integrated into the new environment, they will be endowed with new connotations and meanings, so they are no longer limited to the pure category of the national culture. Guangxi Zhuang brocade In the process of reform and open to the outside world, Guangxi Zhuang brocade techniques have been integrated into the modern global cultural system from the ancient agricultural civilization, but both the government and the people have shown strong utilitarian needs and aspirations (Ning, 2010, P: 8-12).

To sum up, under the background of the deepening of reform and open to the outside world, Zhuang brocade, a traditional textile vigorously promoted by the government, has gradually surpassed the boundaries of its material level and become the core symbol of Zhuang culture. Its connotation and extension have been significantly expanded and deepened. For example, the creation of Zhuang brocade culture in A Zhuang brocade is set in the folk story through cartoons and opera forms. Successfully shaped the cultural image of the Zhuang people and the Zhuang brocade. In the music Zhuang brocade cultural symbols, through the song "Zhuang brocade to Chairman Mao" sung throughout the country. In the creation of Zhuang brocade cultural symbols, the opera Zhuang brocade, funded by the Baise municipal government in 2008, linked Zhuang brocade with the happy life of the Zhuang people.

In addition, there are the traditional Chinese painting work "Zhuang brocade" created by the famous artist Mr. Huang Gesheng, and the urban roads named after Zhuang brocade in Nanning, brocadexi and other places, which all reflect the deep integration and innovative application of Zhuang brocade culture in literary and artistic creation and real life. With the deepening of public cultural construction, the derivatives of Zhuang brocade and its innovative communication forms also show increasingly rich diversity. Guangxi Zhuang brocade Has become an important symbol of Zhuang culture, from the real supplies of daily life to music, architectural design and public environment and other dimensions, making Guangxi Zhuang brocade cultural value has been more widely used and inherited. Therefore, in the government's shaping of Guangxi Zhuang brocade culture, Guangxi Zhuang brocade has injected new vitality into the inheritance and development of Zhuang culture in these cross-border integration strategies, while highlighting the unique charm and

charm of Guangxi Zhuang brocade. At the same time, it promoted the transformation of Guangxi Zhuang brocade from the zhuang folk textile skills to the symbol of the modern Zhuang culture, and contributed a unique strength to the integration with the modern society.

**Part II: The creation of "giant" Guangxi Zhuang brocade and the influence of
——Guangxi Zhuang brocade have become the "traditional invention" of
Zhuang cultural symbols**

This section studies and analyzes the creation of giant Guangxi Zhuang brocade and the influence of ——Guangxi Zhuang brocade to become the invention of zhuang cultural symbols. It is divided into two parts. The first is the overview of "giant" Guangxi Zhuang brocade, which analyzes and studies five giant Zhuang brocade built from 2004 to 2021, and the second is the "giant" Guangxi Zhuang brocade "and" traditional invention " process. Since China into reform and open to the outside world, although Guangxi Zhuang brocade has ushered in the short business development peak, but with the in-depth development of marketization, Guangxi Zhuang brocade ontology development has been unable to adapt to China's current market economy model, gradually withdrew from the zhuang people's daily life, lost the survival of the mass base, its survival condition is at stake, is facing the severe test of survival. By 2006, the brocadexi Zhuang loom technology was included in the first batch of national intangible cultural heritage list, bringing a turning point for the living inheritance of Zhuang brocade, and giving Zhuang brocade a new mission, making it one of the iconic symbols of Zhuang culture. Guangxi Zhuang brocade Has entered the "traditional invention" process, until now.

2.1 Overview of the "giant" Guangxi Zhuang brocade

(1) 2004 "Double wind toward the flower" Zhuang brocade big wall hanging

In 2004, at the China-ASEAN Expo, the Zhuang brocade large wall hanging carefully woven by Guangxi Institute of Arts and Crafts was officially unveiled (Figure 43). The work is 3.3 meters long and 4.1 meters high, and takes red as the background color. The central part significantly shows the logo of China-ASEAN Expo, and the most typical large phoenix bird pattern in Zhuang brocade is integrated on both sides. In the upper part of the work, the yellow lines cleverly weave the meaning of "sincere cooperation for the future", while in the lower part, through 11 human patterns, symbolizing the close cooperation and cooperation between China and ASEAN countries. This work represents the first time that 48 million ethnic children in Guangxi have presented Zhuang brocade as a unique cultural gift to the expo. Its exquisite craftsmanship and beautiful patterns have not only impressed the domestic audience, but also won wide praise from the international community. Since then, Zhuang brocade's reputation has improved significantly across the country and has begun to move to the world stage. The appearance of this Zhuang brocade not only fully demonstrated the unique charm and profound heritage of Guangxi national culture, but also began to establish the status of Zhuang brocade as a cultural symbol of Guangxi.



Figure 44 "Double wind toward the flowers" Zhuang brocade big wall hanging
Source: Tan Xiangguang shot 7 / October / 2004

(2) 2007 "Celebrating the 10th Anniversary of Hong Kong's return" Zhuang brocade big wall hanging

In 2007, by the museum of Guangxi Zhuang autonomous region and Guangxi gold Zhuang brocade culture art co., LTD., Guangxi institute of arts and crafts specific execution of Zhuang brocade, Chinese folk craft master Tan Xiangguang under the guidance of the creation of the tenth anniversary of the return of Hong Kong to Zhuang brocade large wall works, its height of 3.5 meters, width of 2.4 meters, at that time is recognized as the Zhuang brocade art "the world's most" (Figure 44). With the core theme of celebrating the 10th anniversary of Hong Kong's return to the motherland, the work cleverly integrates the beautiful scenery of Hong Kong Victoria Port and the traditional Zhuang pattern elements into the pattern design. The overall pattern is divided into three areas: the upper part shows the characters of the 10th anniversary of Hong Kong, the symbol of Hong Kong, — Bauhinia, and the bottom shows the city view of Hong Kong Victoria Harbour. The whole work is closely related to the theme and deeply expresses the sincere wishes of the people of Zhuang Township, Guangxi, for the 10th anniversary of Hong Kong's return to the motherland.



Figure 45 Celebrating the 10th Anniversary of Hong Kong's return" Zhuang brocade big wall hanging

(3) 2010 "Guangxi Zhuang brocade Xian World Expo" Zhuang brocade large wall hanging

In 2010, "Guangxi Zhuang brocade Xian World Expo" Zhuang brocade large wall hanging, as a gift, presented to the Shanghai World Expo (Figure 45). The Zhuang brocade is 6.6 meters long and 3.68 meters wide, which is completed by the Zhuang people weaving more than 100,000 needles, which embodies the cultural feelings and hard work of the Zhuang people and shows the exquisite traditional craftsmanship of the Zhuang nationality. The giant wall pendant uses bright yellow as the main color, and the rich patterns on it are presented through 16 fine colored silk thread weaving techniques. At the top of the picture, two colorful phoenixes are close to the emblem of the Shanghai World Expo, dancing and lifelike. The Zhuang people regard the phoenix as an auspicious divine bird, representing that Guangxi is the land of the phoenix. Under the phoenix, the hydrangea is elegant, which not only reflects the traditional virtue of hospitality of Guangxi people, but also enriches the sense of hierarchy and cultural connotation of the picture. In the middle of the pattern, the words "Guangxi Zhuang brocade for the Expo" are clearly marked in Chinese, Zhuang and English, highlighting the keen concern and deep friendship of the Guangxi people to the Expo. Zhuang brocade The core pattern is a map of the world composed of doves of peace, implying good wishes for global peace. Under the dove of peace, 12 ethnic groups in Guangxi gathered around the bronze drum to celebrate the grand opening of the World Expo, which symbolizes the unity and harmony of the people of all ethnic groups in Guangxi (Li, 2010).



Figure 46 Guangxi Zhuang brocade for the Expo Zhuang brocade wall hanging

Source:https://mp.weixin.qq.com/s?_biz=MzA4NTU1OTI1NQ==&mid=2650507418&idx=1&sn=3a3a6866ca605383f0775bc36078b901&chksm 17/January/2024

"Any work, if it is beautiful, must be expressive, and it is not a concept of something else, but a concept of some emotion (Brown, 1983, P: 120)." 《Guangxi Zhuang brocade At the bottom of the big wall, is a beautiful peace knot pattern, it carries the deep blessing of Guangxi people to the people of the world, carries the beautiful feelings of the Zhuang people, and expresses the sincere blessing of peace

and good luck to the people of the world. In addition, in the same year, Guangxi Zhuang brocade, Offering the Expo won the "largest Zhuang brocade" in the Guinness World (Figure 46).



Figure 47 "the largest —— and largest Zhuang brocade in the Guinness World" issued by the Guinness Headquarters in Shanghai

Source: Wang Zhiqing published "Research on the connection between Brocade

Technology Development and Equipment in Guangxi" paper 1 / January / 2024

(4) 2019 "Zhuang Xiang Happiness Road" Zhuang brocade big wall hanging

In 2019, the Zhuang Xiang Happiness Road completed by Guangxi Arts and Crafts Research Institute Co., Ltd., a Zhuang brocade wall hanging 6.7 meters high and 3.7 meters wide and a Zhuang brocade couplet 5.75 meters high and 0.43 meters wide, became the largest single Zhuang brocade work in the world at that time (Yan, 2021, P: 32-42). The work takes the image of Guangxi Baise Expressway as the theme, takes the Guangxi expressway network as the core element, and takes the dynamic color of Zhuangxiang Red as the main color. The production cycle of the whole work is half a year, and the traditional and exquisite weaving technique is adopted, which is made by hand by hand and line by hand. The work significantly shows the magnificent scene of Baibrocadeg Expressway Jiuzhou Interchange. As an outstanding representative of Baise Expressway, this section is known as a "China — ASEAN International Channel" full of vitality and vitality, and it is also an important road to prosperity and happiness for the people of Guangxi to realize the great rejuvenation of the Chinese dream.

(5) 2021 "Beautiful Strong Brocade Dedicated to the Party" Zhuang Brocade Long Scroll

In celebrating the centennial birthday of the communist party of China, longzhou golden dragon town double village plate pool chariot twelve woven niang, with deep gratitude to the party and longing for the future life, carefully woven on a

picture called "beautiful Zhuang brocade to the party" the huge Zhuang brocade long work, to express the party's lofty respect and good wishes. His works are 12 meters long and 2.3 meters high, consisting of 6,120 meridians and 28,000 latitude threads. In the middle of the Zhuang brocade, the logo of the 100th anniversary of the founding of the Party is displayed, and the bottom two lines of characters "Long live the Communist Party of China" and "Long live the national unity" shine, highlighting the lofty theme. The main characters in the work are composed of young men and women dressed in costumes, who represent the 12 ethnic groups living in Guangxi, under the light of the Party, singing and dancing with joy to pay high respect to the party's birthday. In addition, the pattern is also cleverly integrated into the bronze drum, Xianglu, Fengdeng and other representative cultural elements in Guangxi (Figure 47).



Figure 48 "Beautiful Zhuang brocade dedicated to the Party" Zhuang brocade long scroll

Source: https://m.thepaper.cn/baijiahao_13181655 17/January/2024

In the process of weaving, a total of 12 colors of silk thread were selected, which not only enrich the visual effect of the work, but also symbolize the common pursuit of a happy life among 12 ethnic compatriots including Zhuang, Han, Yao, Miao, Dong and other Guangxi. The whole work deeply reflects Guangxi under the leadership of the Communist Party of China, the good situation of social harmony and stability, ethnic unity and harmony, peaceful consolidation of the border areas, beautiful ecological environment, as well as the high and positive spirit of the people. This work is undoubtedly a symbol of the gratitude of the Zhuang children, follow the party "happy picture".

In the weaving process of Zhuang brocade, an improved leading textile machine with a height of 5.5 meters and a width of 3 meters is adopted. The manual weaving method of "crossing longitude", the pattern structure is complex and fine. What is particularly noteworthy is that the diameter of the wire we use is only less than half the diameter of the traditional wire, and the whole weaving process is required to be formed once without seams. Therefore, this weaving method is much more difficult than the traditional Zhuang brocade weaving.

With the cooperation of 2 to 3 weavers in each group, each shift works for 8 hours and can weave up to 4 cm Zhuang brocade, which fully reflects its precious value and difficult technology. It can be described as "precious gold". This brocade activity was attended by 12 weavers, all of whom have rich experience in brocade, with the oldest weaver reaching 77 years old. These weavers are masters of brocade, inheritors of skills and examples of poverty alleviation through brocade. It is worth mentioning that Li Xuejiao participated in the brocade activity together with her daughter Pan Junxin and her mother Huang Xiu'e, showing the family inheritance and development of Zhuang brocade weaving skills.

2.2 "Giant" Guangxi Zhuang brocade "traditional invention" process

(1) A "traditional invention" in the form of a "giant" Guangxi Zhuang brocade
 Guangxi Zhuang brocade The "giant" presentation. First of all, it significantly reflects the self-awakening and awareness of the Zhuang people to their national culture. Secondly, the "giant" size breaks the traditional width limit of Zhuang brocade 20 cm to 50 cm. The innovation and creation of this size not only sublimate the Guangxi Zhuang brocade in form, but also promotes this folk handicraft to transform into a symbol of the Zhuang people and their culture. Moreover, with the active intervention of government forces, using the traditional function of Zhuang brocade as a gift and displaying in major events, successfully shaped the "traditional" value of "giant" Zhuang brocade. In this process, the participation of the government not only affects the creative purpose and use of Zhuang brocade, but also gives it new value and significance. Finally, the transformation of Guangxi Zhuang brocade from "small" to "big" is not only the embodiment of the awakening of Zhuang brocade cultural nomenclature, but also a firm display of Zhuang people's confidence in their own culture, which can be regarded as a kind of "traditional invention".

(2) The "traditional invention" of the "giant" Guangxi Zhuang brocade usage scenario

Traditional Guangxi Zhuang brocade plays an important role in the life scenes, such as wedding customs, folk activities and the exchange of daily gifts. Driven by the dual forces of the government and the people, the "giant" Guangxi Zhuang brocade was brought to the scene of major national events or major events in Guangxi. As Hobbawm puts it: "Changes to old uses occur in a new environment and use old patterns as new purposes (Eric & Terence, 2020, P: 6)." Under the shape of the government, the use scenario of the "giant" Guangxi Zhuang brocade has changed significantly compared with the traditional Zhuang brocade. It not only from the Zhuang people "gift" in daily life, was given the symbolic significance of the Zhuang and Guangxi, but also inherited the traditional Zhuang brocade as the function of "ritual", and on the basis of the rich its cultural connotation, beyond the family, love, friendship, become and has profound history and traditional Guangxi Zhuang brocade symbol. Today, "Giant" Zhuang brocade has gone beyond the scope of textiles used by the Zhuang people, has been given a new symbolic significance, and become an important cultural symbol of the Zhuang people and Guangxi Zhuang Autonomous Region.

(3) The "traditional invention" of the "giant" Guangxi Zhuang brocade pattern
 The presentation of the "giant" Guangxi Zhuang brocade has opened up a new road for the evolution of the Guangxi Zhuang brocade patterns and patterns. First, the "giant" Guangxi Zhuang brocade was born with a clear actual need, which in turn makes Guangxi Zhuang brocade an effective tool for government services. Secondly, each "huge" Guangxi Zhuang brocade is closely related to the theme of a specific scene and carefully created around the activity logo, such as the logo of China-ASEAN Expo, Shanghai World Expo and the logo of the 100th anniversary of the founding of the Communist Party of China, which have become the core patterns in Zhuang brocade works. Thirdly, in order to enrich the content of the work, the designers integrated the patterns and patterns related to the activity into the design. For example, in the Zhuang brocade wall of "Celebrate the 10th Anniversary of the Return of Hong Kong", the symbolic symbol of Hong Kong and the city scenery of

Hong Kong Victoria Port. Finally, with the continuous change of use scenarios, Zhuang brocade pattern enters a "traditional invention" process under the promotion of the government. Although this innovation is divorced from the original foundation of Zhuang culture, it aims to serve new groups and shows the era value of Zhuang brocade culture.

(4) The "traditional invention" of the "giant" Guangxi Zhuang brocade looms and materials

In the invention process of the "Giant Giant" Guangxi Zhuang brocade, it also encountered many difficulties. First of all, the "giant" Guangxi Zhuang brocade machine is divided into two types, one is the traditional Guangxi brocade to complete the part, and then the whole stitching to complete the "giant" Zhuang brocade; the other is the use of improved silk loom, using semi-manual and semi-mechanical way, one-time weaving into a "giant" Zhuang brocade. As Chinese arts and crafts master Tan Xiangguang introduced, it is a very challenging task to weave a huge Zhuang brocade with delicate and vivid patterns. In terms of material selection, the raw materials of traditional Zhuang brocade have been optimized, and the finest real silk thread has been selected by hand, so as to ensure that the "huge" Zhuang brocade pattern is stronger and smoother than that of traditional Zhuang brocade. Under the guidance of Ms.Tan Xiangguang, each group consists of four highly skilled weaver girls, in front of the 4.5 meters long and 3 meters high improved silk loom, referring to the "Italian craftsman map", at a consistent speed for manual jacquard. In this process, there should not be any mistakes, otherwise the whole team will have to rework (Li, 2010). On the premise of ensuring the steady progress of the weaving work, eight weaver girls were divided into two groups for rotation operation. After 96 consecutive days of hard work, a total of more than 100,000 needles, finally successfully completed the "Guangxi Zhuang brocade Expo" this Zhuang brocade wall work.

Guangxi Zhuang brocade Weaving is innovated by the emergence of "giant" Zhuang brocade, which not only optimizes Guangxi Zhuang brocade's loom and velvet, but also significantly improves Guangxi Zhuang brocade's production capacity. Although the "Giant Giant" Guangxi Zhuang brocade was originally presented on various occasions as a gift to the Zhuang people, the new production loom and velvet materials introduced by it have played a key role in promoting the modernization of the Guangxi Zhuang brocade industry. Since 2006, Guangxi Zhuang brocade has also been revitalized in the production field, a process that demonstrates the charm of "traditional invention".

(5) "Giant" Guangxi Zhuang brocade shapes the cultural symbol "traditional invention" of zhuang cultural symbols

According to the literature records, Guangxi Zhuang brocade in the early Qing Dynasty was a royal tribute, and "Giant" Guangxi Zhuang brocade, as an outstanding representative of the new invention of this traditional craft, continued the cultural tradition of Zhuang brocade as a "gift", and appeared in major international events for many times. Specifically, it was presented at the first China-ASEAN Expo in 2004, the 10th anniversary of the celebration of Hong Kong's return in 2007 and the 2010 Shanghai World Expo, which attracted wide attention from participants and the media. This series of displays not only highlight the artistic charm of Zhuang brocade,

but also further establish the status of Zhuang brocade as an important cultural image and cultural symbol of the Zhuang nationality.

In addition, under the government's strong advocacy and promotion of the gift, Guangxi Zhuang brocade with its distinctive Guangxi local characteristics and unique national craft charm, has become the first choice of the government and foreign exchange departments. With the help of Zhuang brocade as a gift, the "giant" Guangxi Zhuang brocade is presented in various major events, which becomes a fixed ceremony to express good wishes to the participants and the event organizers, and is also an important carrier to show and publicize the cultural image of Guangxi and the Zhuang nationality. Thus, under the influence of the story of a Zhuang brocade, began to "ancient traditional art" culture image appeared frequently in the field of popular culture, an ancient loom, gray old mother and a cute little girl in the face of mother's exquisite brocade technology exclamation become communication people in the past and present, present and future imagination (Ning, 2010, P: 12).

Since 2006, Guangxi Zhuang brocade has been officially included in the national intangible cultural Heritage protection project, which has not only endowed Guangxi Zhuang brocade with a new cultural value, but also greatly promoted the continuous creation and presentation of the "giant" Guangxi Zhuang brocade. Subsequently, the application scene of Guangxi Zhuang brocade also changed significantly, from the original traditional use of the Zhuang people to express family love and friendship in daily life, through the conscious guidance of the government, gradually integrated into the national major activities, thus giving Guangxi Zhuang brocade in the reform and open to the outside world new period of cultural mission and the distinct symbolic significance of Zhuang culture. This change marks that Guangxi Zhuang brocade is no longer confined to the category of folk art, but has been recognized and supported by the official, and has become one of the important forces to promote the Zhuang culture, and also constitutes an important link in the process of Guangxi Zhuang brocade "traditional invention".

Part III: A "traditional invention" analysis of the Guangxi Zhuang brocade technique

This section studies the analysis of the "traditional invention" analysis of the Guangxi Zhuang brocade technique. It is divided into three parts, the first is the traditional Guangxi Zhuang brocade loom; the second is the improved Guangxi Zhuang brocade loom; the third is the practice of the Guangxi Zhuang brocade loom "traditional invention".

3.1 Traditional Guangxi Zhuang brocade loom

Guangxi Zhuang brocade The birth of brocade machine, in the central Plains textile technology and the integration of zhuang textile traditional technology crystallization. The number of textile tools unearthed at the Han Dynasty site of Luobo Bay in Guizhou County is abundant, but these tools have not been recovered in time and the related historical documents are less recorded, so we cannot intuitively appreciate the superb textile skills of the ancient Guangxi Zhuang ancestors. The early practice of textile and brocade in Guangxi mostly relied on an original tool called "waist machine", which was characterized by tying the weaving axis to the waist for operation. This skill still remains in some parts of Guangxi. With the prevalence of Guangxi Zhuang brocade weaving and the improvement of looms, Guangxi Zhuang

brocade looms appeared in bamboo cage machine and brocadegxi loom after the original waist machine, oblique loom, multi-integrated and multiple thread looms (Chu & Lv, 2021, P: 107-111). Guangxi Zhuang brocade The main production areas are concentrated in brocadegxi, Binyang, Xincheng, Longzhou, Huanjiang and other counties and cities. Among them, brocadegxi Zhuang brocade loom, Binyang bamboo cage machine, Huanjiang Zhuang brocade loom and Longzhou Zhuang brocade loom are the most representative loom styles. Although Zhuang brocade looms in Guangxi are slightly different in details due to regional differences, they generally adopt wood materials as the main composition, and their structural design covers key parts such as support system, transmission device, integrated device and jacquard device. Based on the different ways of Guangxi Zhuang brocade loom opening and lifting, the traditional Zhuang brocade wood looms can be divided into three types: single single integration, double single integration and double multi-integration (Fan & Dao, 2021, P: 107-117) (Table 13).

type	name	body frame	Roll axis	brocade	heddle
Single tiptosis	Longzhou Zhuang brocade machine	Half frame	Waist type		a slice
Double tiptosis	Binyang bamboo cage machine Xincheng bamboo cage machine	Half frame	Waist type		a slice
Double tiptosis	Ring river brocade machine	Half frame	Waist type		two pieces
Double tiptosis	brocadegxi brocade machine	Full frame	stationary type		two pieces

Table 12 Traditional Guangxi Zhuang brocade loom classification

Source : Yaocheng Tian, Author : 17/January/2024

(1) brocadegxi Zhuang brocade loom

brocadegxi brocade machine (Figure 48) is mainly used by the Zhuang people in several counties in brocadegxi and western Guangxi. Its fuselage consists of two parts: chassis and rack. The fuselage is generally 173 cm long and is an inverted trapezoid. The front end is 65 cm wide and the rear end is 77 cm wide. The front end of the machine is equipped with a sitting board, and the back end undertakes the rack. The rack is generally 77 cm high. Usually, the yarn starts from the rear beam of the frame, drops vertically to the water after the shaft, through the comprehensive and reed to the rolling shaft. The reed device is on the swing rod, with the gravity and inertia of the swing rod. After the reed, there are two pieces of earth, composed of the box and silk, and the bamboo pole as the box, between the silk. Two pieces of the pedal. About 30 pieces of jacquard filament are placed after the ground ensemble. The jacquard ensemble is composed of composite rod and composite silk, arranged from

front to back, and suspended from the rack. When weaving flowers, according to the requirements of the weaving pattern to mention the jacquard pieces, affecting the thread to form the opening, weaving flowers (Wu, 1990, P: 50-55). In addition, after the brocade machine, it can be directly used to textile the traditional earth cloth of the Zhuang nationality.



Figure 49 brocade machine (traditional type)

Source: Yaocheng Tian was taken in brocade machine 17 / Julie / 2023

(1) Binyang bamboo cage machine

Binyang bamboo cage machine (Figure 49), this kind of brocade machine distribution range is very wide, south to Xincheng and Binyang, north to Huanjiang and other places. It is mainly made of bamboo and wood, equipped with support system, transmission device, integrated device and jacquard device and other key parts. The fuselage is 173 cm long and is inverted trapezoidal from the tip to the back end. The front end is 65 cm wide and the rear end is 79 cm wide. Rack height of 109 cm. There are two lever structures in the middle and upper part of the frame, which are used to lift the ground and weave the bamboo cage with flowers, hence the name bamboo cage machine. The lever of the bamboo cage is 150 cm long and heavy at the back end to maintain balance. A bamboo stick is hung from both ends of the bamboo cage to separate both sides. The bamboo needle rows around the bamboo cage, and the whole bamboo cage is the flower book. Weaving flowers to remove the bamboo needle according to the programmed order, pull up a group of jacquard thread can affect the thread to form an opening. The number of bamboo needles on the bamboo cage machine can reach more than 100, less than 30, according to the prohibition of brocade pattern. Bamboo cage machine only a piece of land, with stepping rod, can complete the flat weaving. This field is not a rectangular frame, it consists of a filament and a rod of each filament to build a foundation. The lever is connected to the lever, and the back end of the lever is connected to the pedal. The process of forming the shuttle mouth in the bamboo cage machine is that there is a diameter of about 14 centimeters in front of the axis of the bottom meridian and the surface meridian, thus forming the first floor mouth. Stepping on the pole, because of the lever to lift the ground, the bottom followed and follow, into the surface. The second

shuttle mouth formed is very small, and it also needs to pass a pointed bamboo tube to increase the building mouth to facilitate latitude introduction. After the bamboo tube was removed, the stepping rod was released, and the original form was formed into the first building mouth (Wu, 1990, P: 50-55).



Figure 50 Binyang bamboo cage machine

Source: Yaocheng Tian was taken at Nanning Museum 17 / Julie / 2023

In addition, similar bamboo cage machines also exist in Wenping, Xiannan and Chuanshan areas of Huanjiang Maonan Autonomous County, whose appearance and operation principle are significantly similar to those of Binyang bamboo cage machines. For example, the bamboo cage machine and Binyang bamboo cage machine are slightly reduced in size, but they still maintain a high degree of consistency. The bamboo cage machine in annan and Chuanshan is slightly different in details. The length of the machine is set to 160 cm, and the machine triangular design is adopted. The bamboo cages in the area are exquisitely designed, and the number of bamboo needles is steadily maintained at about 40. It is worth mentioning that the suspension device of these bamboo cage machines is unique. The back end of the lever is directly connected with the pedal, so that the operator needs to keep the close contact between the feet and the stepping rod in the process of work, and can not leave easily. In addition, this type of bamboo cage machine is not equipped with the traditional building structure, but in dealing with the latitude, it cleverly uses a latitude knife with the same function of the building, its shape is the same as the latitude knife used in the Huanjiang brocade machine.

Through consulting information, Qian Xiaoping also described in detail the brocade machine of the Zhuang nationality in the Republic of China, whose structure is similar to the Binyang bamboo cage machine (Figure 50). It is mainly composed of machine tool and rack. Generally, the captain is 173cm, inverted trapezoidal, with the front end 65cm wide and the back end 77cm wide. The front end of the machine tool is equipped with a sitting board, and the back end undertakes the rack. The rack height is 77cm, and the lever starts from the back beam of the rack, and the upper end

of the lever hangs the flower cage and the heavy weight; the lower end of the lever raises the opening, and the gravity and inertia of the lever. Behind the reed is a piece of earth, which is rectangular and composed of filament and bamboo frame (upper and lower rods, intermediate filament). This kind of loom can be used for brocade after the jacquard. After the jacquard is placed in the ground, it consists of integrated rods and lines, arranged from front to back and suspended on the rack (Qian, 2014, P14-15). It can be used as a reference for analyzing the evolution of the bamboo cage machine.

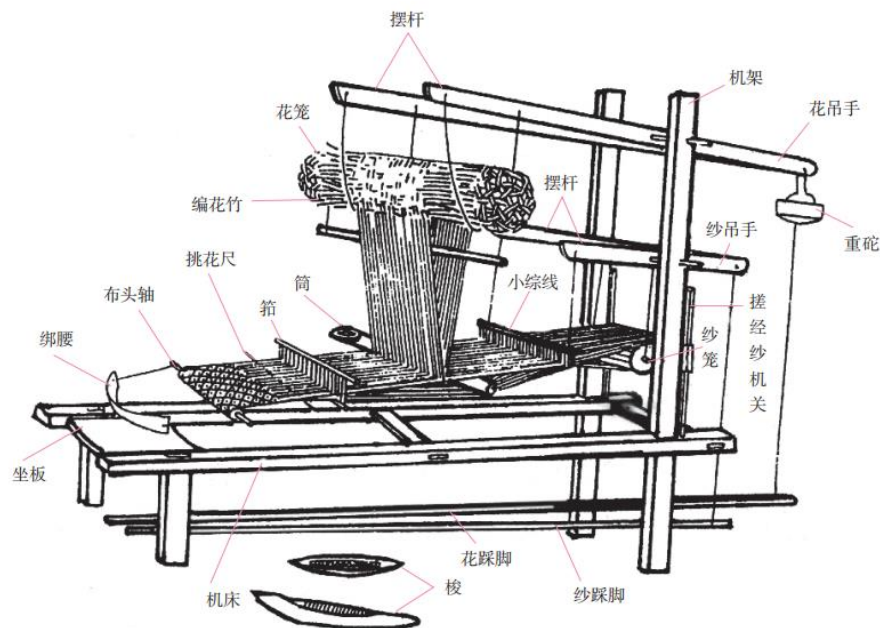


Figure 51 Structure diagram of the Zhuang brocade loom in the Republic of China period

Source: Qian Xiaoping, Shen Bei. Chinese brocade book · national brocade. China Textile Press 17/January/2023

(3) Huanjiang Zhuang brocade loom

Huanjiang Brocade Machine (Figure 51): This brocade machine is mainly distributed in Jiale Township of Huanjiang Maonan Autonomous County.

The machine consists of two parts: console and rack. The lower part is the platform. The fuselage is about 134 cm long, 90 cm wide and 40 cm high. The front end is a movable seat board, and the back end is a meridian shaft. The rack is 90 cm high, and the iron wire at the two ends of the front beam is used to hang the flower book. Two pieces of flat tissue are suspended from the circular bar in the center of the stand, connected to the pedal with a rope. The flowers are made of bamboo needles, with about 40 bamboo needles. Bamboo needles are connected to the jacquard silk, and the number of roots and the total number of roots are the same. The thread passes through the comprehensive eye of the thread one by one, using the flower to control the movement of the thread, so that the yarn forms the mouth, through the latitude, and then pull the bamboo needle, lift a group of silk, the thread out of the opening, the weaving operation. The latitude uses a kind of shuttle function of the latitude eye, using the flower originally to control the movement of the line, weaving when the pedal, the two pieces of comprehensive up and down movement, so that the knife.

The blade mouth is straight, both ends are narrow for holding, the back is flat and wide, hollow into a small groove built-in weft. After leading the latitude, the latitude line can be tightened again. The machine does not have a fixed scroll shaft, but the two ends of the clamp stick in front of the abdomen. Local looms can also be used for brocade weaving. The loom is slightly larger than the loom and has a fixed scroll. Usually, the weaving width is wide, so all the "software" of the brocade machine, that is, the comprehensive frame of two tubes and a set of flowers and reed (Wu, 1999, P: 50-55).

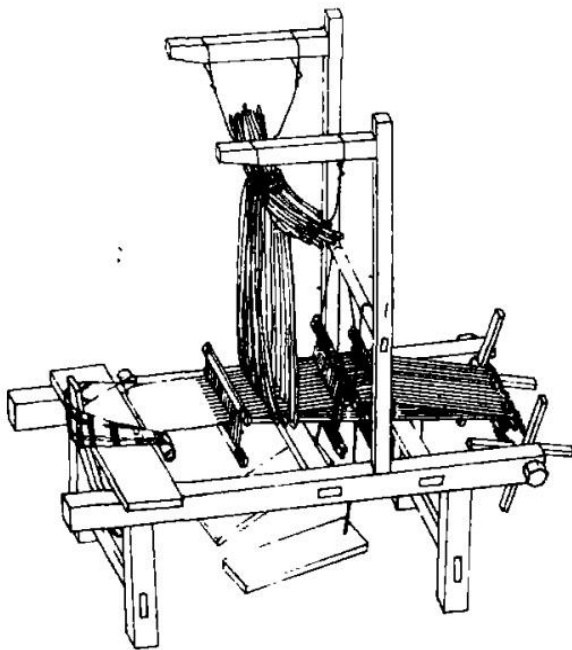


Figure 52 Huanjiang brocade machine

Source: Wu Weifeng published the Brocade Technology of Guangxi Zhuang Nationality in 1990, painted by Tan Zengyi of Guangxi Museum 17/January/2024

(4) Dragon boat Zhuang brocade loom

Longzhou Zhuang brocade loom (Figure 52), popular in Chongzuo Longzhou area of the Zhuang brocade machine. After disassembly and measurement, the total length of the Longzhou brocade machine is about 120 cm, the frame is about 100 cm high, and it is inverted trapezoidal from the front end to the back end. The front end is 72 cm wide and is connected to the rack. The back end is 36 cm wide, equipped with a sitting board, in the shape of a ladder. The width of the anterior and posterior ends was 42 cm and 30.5 cm, respectively. It mainly includes the following parts: fuselage, yarn, yarn, jacquard and other key parts. The fuselage consists of machine tools, racks and seats, which together constitute the basic framework of the Zhuang brocade loom. The loading part includes the winding yarn head, dividing rod, cloth shaft, binding waist and pressing bar, which are responsible for the finishing and conveying of yarn. The yarn part mainly includes the foot, horse's head and small yarn, which are responsible for lifting the yarn to form a pattern. The jacquard part includes flower foot, flower hand (rope), flower tube, flower tube, bamboo weaving, large comprehensive yarn and comprehensive line beam, which work together to make the pattern more colorful. The flower part mainly includes reed, stitch ruler, meridian

tube, velvet spindle, latitude knife and yarn spindle, which are responsible for the process of brocade weaving.



Figure 53 Longzhou brocade machine

Source : https://www.sohu.com/a/387631091_12062949717/January/2024

To sum up, Guangxi Zhuang brocade's traditional looms show diversified style characteristics. Among them, brocade west area brocade machine on structure similar to the loom, but the significant difference is that its additional equipped with a set of jacquard full silk device, this design makes the loom of not only can be used for weaving Zhuang brocade, also can meet the task of weaving, embodies the high degree of flexibility and practicability, and binyang and XinCheng area bamboo cage machine, huanjiang and longzhou Zhuang brocade loom, is designed for weaving Zhuang brocade and elaborate special equipment. These looms are structurally designed to achieve efficient and accurate weaving processes that meet the high standards of Zhuang brocade fabrication. These carefully designed looms not only show the profound attainments of the Zhuang people in their textile skills, but also are a vivid embodiment of their unique wisdom and innovative spirit.

3.2 Guangxi Zhuang brocade loom innovation

Guangxi Zhuang brocade While retaining the essence of the tradition, the loom actively introduces, improves and innovates the Zhuang brocade weaving tools to cope with the changing needs of the market and The Times. There are two core factors to promote Zhuang brocade loom innovation: first, Zhuang brocade productivity is difficult to fully meet the rapid change of market demand; second, the production scale of Zhuang brocade products needs to adapt to the aesthetic improvement of The Times. Specifically, traditional looms, such as bamboo cage machines, brocadegxi and Longzhou Zhuang brocade machines, are limited by their production tools, and can only weave Zhuang brocade with a width of between 0.2 to 0.6 meters, and the production efficiency is low.

In the 1960s, Binyang Zhuang brocade factory took the lead in the introduction of the machine, which made the width of weaving Zhuang brocade jump

to 1.5 meters, and the production efficiency improved 2 to 3 times compared with the traditional bamboo cage machine. After entering reform and open to the outside world, Binyang Zhuang brocade Factory joined hands with Guangxi Institute of Arts and Crafts to deepen the cooperation again, successfully introducing the modern silk weaving jacquard machine, which further promoted the leap of Zhuang brocade weaving technology.

In the process of innovation, Guangxi Zhuang brocade loom gradually formed three main shapes: the local innovation of traditional brocade, the platoon machine based on the improvement of bamboo cage machine, and the computer control machine improved by modern silk loom technology. All three innovative looms retain Zhuang brocade's unique "flower book" device, but they have their own advantages in shape. With the continuous progress of technology, these new brocade machines not only significantly improve the production efficiency of Zhuang brocade, but also achieve a qualitative leap in the width and fineness of the brocade.

(1) Introduce the machine

The machine, originally designed for weaving khool, was named after the careful arrangement and orderly combination of flower plates in its jacquard mechanism. In the 1960s, in order to improve production efficiency, Binyang Zhuang brocade factory took the lead in the introduction of platoon machine technology from Sichuan. Subsequently, Xincheng Zhuang brocade factory also successfully learned from Binyang Zhuang brocade factory and mastered the technology of Zhuang brocade weaving.

Rmachine (Figure 53), 190 cm long, 90 cm wide, 280 cm high, including upper, middle and lower three parts. The upper part is the core of the jacquard device, which is composed of a single wood arrangement. The small pieces of wood under each piece are arranged according to the pattern to form a symbol code pattern. In the middle of the jacquard line is the ensemble. The upper end of the line is connected by a copper strip and the small wooden block at the bottom of the thread, the middle end of the plate connects the thread, and the bottom is perpendicular to the bottom of the thread. A jacquard line corresponds to a small square. There is a special retreating device at the position of the connecting strip rack, which can be "withdrawn" during Zhuang brocade weaving errors. The lower part is jacquard and plain weaving, including disc veil, warp tube, flat comprehensive, flat pedal, jacquard pedal, etc. (Chu & Lv, 2021, P: 107-111).





Figure 54 Bmachine

Source: Yaocheng Tian was taken at Nanning Museum 17 / Julie / 2023

The advantage of the platoon machine is that the strip still adopts the traditional Guangxi Zhuang brocade cotton yarn as the warp and the velvet as the latitude weaving method, whose style and texture are no different from Zhuang brocade (Wu, 1999, P: 122-125). Secondly, in terms of efficiency, the discharge machine is usually applied to the square continuous small pattern with a small number of knitting needles. Its large width can reach 1.5 meters. Compared with the traditional brocade machine, its power is increased by 2 to 3 times, which can significantly improve the production efficiency. In addition, the jacquard mechanism of the discharge machine is cleverly installed on the wooden frame above the loom, so that the weaver can stand and work, thus effectively reducing the force of the weaver waist, and improving the comfort and efficiency of the work. Finally, from the perspective of structure, the sublaying machine is more simple than the bamboo cage machine, which makes the weaving process more convenient and efficient.

(2) Improve the traditional loom

In the process of inheritance of the traditional brocade machine, although it is also constantly evolving and developing. However, after reform and open to the outside world, the market demand and width expansion of Zhuang brocade have become a huge resistance to the development of Zhuang brocade. For example, Wang Zhiqing improved Binyang bamboo cage machine (Figure 54), the fuselage length is 160 cm, 160 cm high, the bamboo cage length is 120cm, the diameter is 30~50cm, the size of the diameter is determined according to the length. The bamboo needle on the bamboo cage is arranged according to the fabric structure and the density of the product and the size of the pattern. The improvement has many advantages in Zhuang brocade weaving. First of all, there is a pattern memory function, improve production efficiency, reduce the mental labor intensity of the weaver. Secondly, the weaver can sit on a stool to work, to reduce the physical labor intensity of the

weaver.(Wang,2017,P:124-125). Although the production efficiency and the labor intensity of the weaver were improved to a certain extent, this improvement was based on the frame of Binyang bamboo cage machine to solve the problem of Zhuang brocade narrow range.



Figure 55 Bamboo cage machine improved by Wang Zhiqing

Source: Wang Zhiqing published the paper "Exploration on the connection between Guangxi Brocade Technology Development and Equipment" 7/January/2024

For another example, brocadegxi Zhuang brocade factory is also facing the problem of Zhuang brocade width limitation. To solve this problem, the factory has widened the traditional Zhuang brocade loom in brocadegxi, successfully expanding the width of Zhuang brocade to 1.4 meters. However, this improvement also brings the corresponding challenge of requiring two weavers to work together to complete a Zhuang brocade weaving in the weaving process. Despite a breakthrough in width, it has also led to a decline in productivity and increased labor costs (Figure 55).



Figure 56 brocadegxi Zhuang brocade loom (improved type)

Source: Photo taken by Tian Yaocheng brocadegxi City 17/January/2024

(3) Innovative silk weaving jacquard machine

After reform and open to the outside world in China, the traditional Zhuang brocade production mode ushered in a brief development, followed by the impact of industrial textiles, the Guangxi Zhuang brocade market also entered the degree of difficulty. Therefore, Guangxi institute of arts and crafts introduced silk loom, keep the traditional Guangxi Zhuang brocade typical fault weaving way, through the key parts of silk loom, the radian of shuttle plate, reed Angle, shuttle system innovation, and improve the power, eventually achieve mechanization + artificial production. The most representative is K-84 type 22-400 innovative silk loom (Figure 56). In 2010, it completed the largest weaving task of "Guangxi Zhuang brocade Expo" at that time, and won the "Guinness of the Great World" issued by the Headquarters of Great World in Shanghai. K-84 type 22-400 innovative silk loom solves the process of Guangxi Zhuang brocade weaving from manual weaving bamboo cage machine to mechanization, while the product also has the traditional Guangxi Zhuang brocade characteristics and style. Its advantages are as follows: first, K-84 type 22-400 innovative silk loom is 4 meters; second, the production form realizes mechanization + artificial extraction, reduce labor force and improve production efficiency. However, K-84 type 22-400 innovative silk loom also has shortcomings: first, the loom has slow speed, low efficiency, many processes and high labor cost; second, poor safety performance makes the shuttle miss the orbit to hurt the operator; fourth, Zhuang brocade products are known for "heavy", while K-84 type 22-400 innovative silk loom is a relatively light weaving machine, which is difficult to meet the high-density "heavy" Zhuang brocade products (Wang, 2017, P: 124-125).



Figure 57 K-84 type 22-400 silk loom

Source: Exploration on the connection between Guangxi Brocade Technology Development and Equipment published by Wang Zhiqing 7/January /2024

In order to solve the shortcomings of K-84 type 22-400 innovative silk loom, Guangxi Institute of Arts and Crafts purchased 747-230 and 747-250 sword pole loom for improvement and innovation. In the continuous testing and improvement, it finally combined the transmission of K-84 silk loom and rear beam to solve the problem of rough yarn and thread in the jacquard loom, reduced the weaving defects, and achieved the traditional Guangxi Zhuang brocade effect (Wang, 2017, P: 124-125). In addition, the jacquard faucet has also been transformed, modified the electronic flower board device, cancel the original grain plate. Through the use of CAD system, electronic plate output technology, upgrading of mechanical plate penetration, weaving equipment, optimize the selection of flowers and other processes, increase the diversity of pattern design, shorten the product development cycle, and improve the upgrading ability of products (Yan, 2021, P: 32-42). The combination of computer control and the improved innovative silk loom (Figure 57) has reduced the labor costs, achieved significant results, and also greatly improved the production efficiency. Since then, Guangxi Zhuang brocade has entered the production mode of handmade brocade and mechanical brocade coexist.



Figure 58 Silk loom used in Binyang Xiangguang brocade workshop
Source: Yaocheng Tian Photo of 17 / October / 2023

3.3 Practice of the Guangxi Zhuang brocade loom "traditional invention"

Guangxi Zhuang brocade With national cultural attributes, it is the collaborative result of "human", "machine" and "material" (Lu, 2017, P: 100). Therefore, the Guangxi Zhuang brocade loom "traditional invention" is a complex process. First, when demand for Zhuang brocade shifts, forcing Zhuang brocade artists or producers into the passive process of innovating equipment. Second, when the use of Zhuang brocade changes, the traditional Zhuang brocade with a width of 30-60 cm no longer meets the living needs of the Zhuang people, improving the width of Zhuang brocade will also promote the improvement of Guangxi Zhuang brocade loom. Although, in the 1960s, Binyang Zhuang brocade factory took the lead in introducing the platoon machine, making the Zhuang brocade width jumped to 1.5 meters, compared with the traditional bamboo cage machine production efficiency is increased by 2 to 3 times. After entering reform and open to the outside world, Binyang Zhuang brocade factory together with Guangxi Institute of Arts and Crafts, drawing on the inspiration of the introduction of platoon machine, the introduction of silk loom, combined with modern computer control, optimized the process of flowers and other processes, and successfully realized the mechanized production of Guangxi Zhuang brocade.

For example, in the Zhuang brocade large wall weaving, First, you need to solve the size problem of the loom, Among them, Guangxi Institute of Arts and Crafts adjusted the key parts of the K-8422-400 machine, And improve the loom, From the radian of the shuttle plate, reed Angle and shuttle casting system, At the same time to improve the power of the mechanical loom, The mechanical loom meets the requirement of weaving with a width of 4 meters, An important technical breakthrough in the history of the Zhuang brocade, Laid a solid foundation for Zhuang brocade's future broad research and development and innovation, Also provides more direction for the use of Zhuang brocade (Wang, 2017, P:124-125). At the same time, the machine was repeatedly transformed to solve the problem that Zhuang brocade could only weave 45 centimeters wide in the past, which provided technical support for this huge Zhuang brocade without seams and one forming.

Guangxi Zhuang brocade In the process of inheritance, Zhuang brocade "thick" texture and rich pattern. Whether it is the introduction of loom, improved traditional loom and innovative silk loom. First of all, it is necessary to ensure that the brocade has Guangxi Zhuang brocade typical characteristics of "thick". Secondly, in the process of innovative loom improvement, the loom structure can be optimized to reduce the labor force and improve the productivity by retaining the traditional jacquard process. Finally, through the introduction of silk loom improvement technology, the width of Zhuang brocade reached 4 meters, and the width was significantly improved. In the process of in-depth improvement and innovation of brocade machine technology, the giant Zhuang brocade can be realized and widely presented in the public view, and become a bright pearl in the development process of Guangxi Zhuang brocade. Thanks to the full support of the government and the unremitting efforts of Guangxi Institute of Arts and Crafts, through a series of transformation and innovation measures, Guangxi Zhuang brocade's weaving technology has realized a modern transformation, and the production efficiency has been significantly improved, while skillfully retaining the unique traditional charm of

Zhuang brocade. This improvement not only promotes Zhuang brocade products to more closely meet the market demand and meet the diversified expectations of consumers, but also lays a solid foundation for the inheritance and prosperity of Zhuang brocade culture. This is exactly the practical process of the Guangxi Zhuang brocade "traditional invention".

Part IV: Guangxi Zhuang brocade A "traditional invention" analysis of patterns and patterns

This section studies the Guangxi Zhuang brocade pattern and pattern invention analysis. It is divided into four parts, the first is the traditional analysis of Guangxi Zhuang brocade pattern; the second is the invention analysis of Guangxi Zhuang brocade pattern; the third is the traditional analysis of Guangxi Zhuang brocade pattern; the fourth is the invention analysis of Guangxi Zhuang brocade pattern.

4.2 Analysis of 2 Guangxi Zhuang brocade patterns

Zhuang brocade The invention of patterns is the result of the continuous accumulation and innovation of the Zhuang people in the long-term production and life. At present, the innovation of Zhuang brocade pattern is not derived from the traditional observation of daily life. Now, the innovation of Zhuang brocade pattern mainly adopts the following three ways. First, it is the deformation method. By absorbing the traditional patterns of the Zhuang nationality or the excellent patterns of the Chinese nation, the patterns are reproduced according to the aesthetic needs of the Zhuang nationality through deformation treatment. For example, in 1981, Tan Xiangguang copied a flower pattern provided by the piece of Xi'an archaeological staff, and used the traditional Zhuang brocade technique to reproduce the flower pattern Zhuang brocade. She believed that "this is the most expensive brocade pattern in Zhuang brocade" (Figure 58). Second, the fusion method. That is, the rich ethnic culture integration in Guangxi, or the integration of tradition and innovative design expression methods. Tan Xiangguang master hosted Zhuang brocade studio in the inheritance of traditional skills and the research and development of modern Zhuang brocade products, has achieved initial results, their research and development of the series of Zhuang brocade products "double phoenix toward flower" "four phoenix lines" "longevity flower", including "double phoenix toward flower" in the first China — asean expo, customers and the public love, and thus opened the unlimited business opportunities. In July 2007, in Hong Kong General Macao Convention and Exhibition Center, Tan Xiangguang led the world's largest Zhuang brocade to celebrate the tenth Anniversary of Hong Kong's return, leaving a deep mark in the hearts of Hong Kong people (Zhang, 2010, P123-124). Third, the transplantation method. The decorative patterns are directly transplanted from the traditional folk culture of the Zhuang nationality, such as the bronze drum patterns, rock painting patterns, farmer painting patterns, etc., and the Zhuang brocade patterns are innovated through transplantation.



Figure 59 Longevity pattern Zhuang brocade

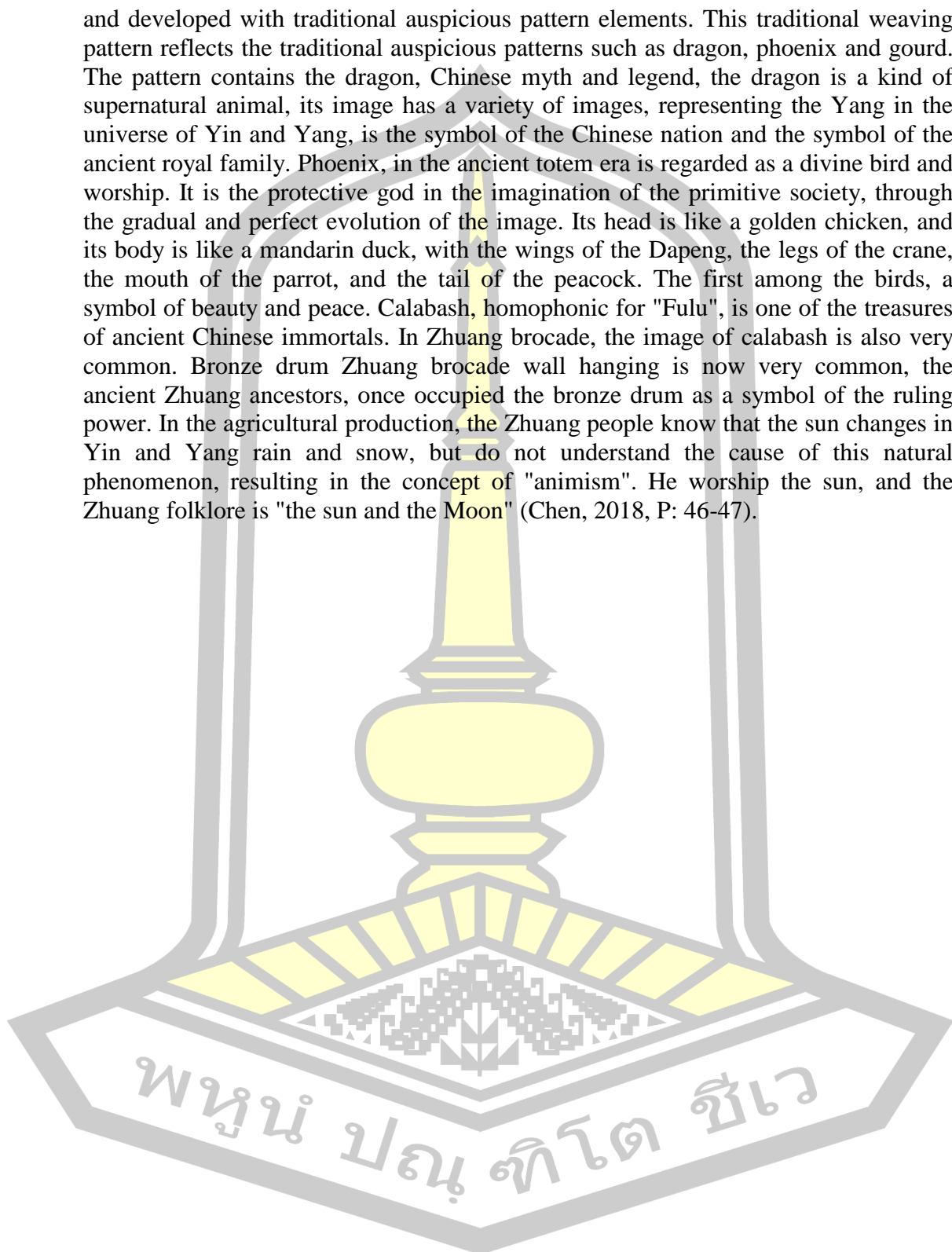
Source: Yaocheng Tian was taken in Nanning Tan Xiangguang Studio 17 / November / 2023

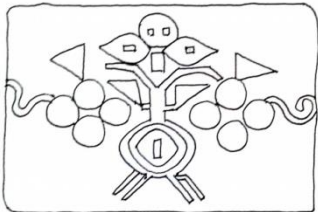
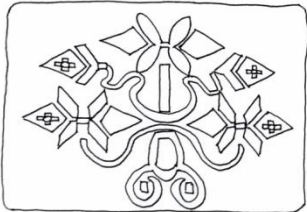
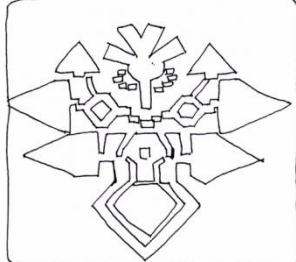
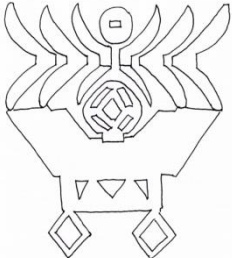
4.3 Guangxi Zhuang brocade, the traditional analysis of the motifs

Reform and open to the outside world Most of the traditional patterns of the front Guangxi Zhuang brocade are lion hydrangea, such as rolling, double phoenix sunrise, pomegranate peony, small flowers, ripples and back patterns. In recent years, with the improvement of the life and cultural level of the Zhuang people, Zhuang brocade has added many new patterns to express the yearning, pursuit and ideological spirit of the Zhuang people, such as animals, eagles, high pigeons, galloping horses, plants, flowers, sunflower, litchi, grapes, spring breeze willows, swift birds, moon and Yunshan, etc. (He, 1987, P: 52).

Reform and open to the outside world On the basis of traditional patterns, innovative use of double phoenix Chaoyang, butterfly flower, double dragon play beads, lion rolling embroidery ball, phoenix wearing peony, mandarin duck splashing, fruit map, butterfly flower, butterfly flower, patron saint, star grain, flower basket, Hexiang, dragon and phoenix dynasty four treasures (Table 18). Zhuang brocade The idea has profound meaning and gorgeous patterns, reflecting the Zhuang people's love and pursuit of a better life. The representative wall hanging has the python dragon pattern Zhuang brocade wall hanging, and the "python dragon" pattern Zhuang brocade is the traditional Zhuang brocade pattern of Guangxi. The figure in the pattern symbolizes the dragon scales, which is the creation pattern sorted from the fragments of unearthed cultural relics. The python dragon pattern symbolizes nobility and is the representative of the current handmade Zhuang brocade in Guangxi. The "longevity flower" pattern in the wall of the longevity flower is the traditional Zhuang brocade pattern of Guangxi. The pattern comes from the pattern elements on the ancient Chinese imperial dress, meaning auspicious and longevity, more than every year. Four blessing bouquet (longevity) Zhuang brocade wall hanging, "four blessing" grain Zhuang brocade for the traditional Zhuang brocade pattern in Guangxi, the pattern of the butterfly around the flower, meaning four butterfly (blessing) bouquet. The four treasure wall hanging pattern of dragon and phoenix Dynasty is designed

and developed with traditional auspicious pattern elements. This traditional weaving pattern reflects the traditional auspicious patterns such as dragon, phoenix and gourd. The pattern contains the dragon, Chinese myth and legend, the dragon is a kind of supernatural animal, its image has a variety of images, representing the Yang in the universe of Yin and Yang, is the symbol of the Chinese nation and the symbol of the ancient royal family. Phoenix, in the ancient totem era is regarded as a divine bird and worship. It is the protective god in the imagination of the primitive society, through the gradual and perfect evolution of the image. Its head is like a golden chicken, and its body is like a mandarin duck, with the wings of the Dapeng, the legs of the crane, the mouth of the parrot, and the tail of the peacock. The first among the birds, a symbol of beauty and peace. Calabash, homophonic for "Fulu", is one of the treasures of ancient Chinese immortals. In Zhuang brocade, the image of calabash is also very common. Bronze drum Zhuang brocade wall hanging is now very common, the ancient Zhuang ancestors, once occupied the bronze drum as a symbol of the ruling power. In the agricultural production, the Zhuang people know that the sun changes in Yin and Yang rain and snow, but do not understand the cause of this natural phenomenon, resulting in the concept of "animism". He worship the sun, and the Zhuang folklore is "the sun and the Moon" (Chen, 2018, P: 46-47).



Combination pattern	implied meaning	case
Fruit map	This figure mostly appears in the Zhuang brocade quilt surface. There are flowers and fruits, meaning that men and women marry and blossom and bear fruit, and have children. I wish you a happy life.	
Butterfly love flower	Butterfly and flower combination. Chinese traditional culture usually compares butterflies to men and flowers to women, and "butterflies love flowers" is often compared to the beautiful love of "talented people and beautiful women"	
Angel	Cattle represent the hard work, industrious, plain spirit, cattle head pattern can also exorcise evil disaster. Bull head lines appear in the child's face, as the child's patron saint, to protect the healthy growth of children.	
Lift the star grain	Zhuang folk witches have the practice of "lifting stars". Cut a small paper man "Mao Lang" (wizard paper cut) inserted in a bowl of "lift star rice", with the help of "Mao Lang" son for money and peace, prolong life, help eliminate the disaster and difficulties. After the end of the wizard, the "MAO Lang" was burned, said that let the "MAO Lang" to take the bad things away, and everything goes well from now on.	

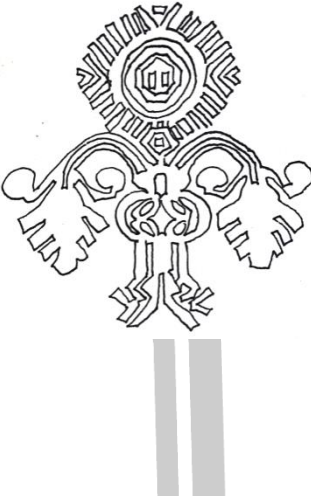
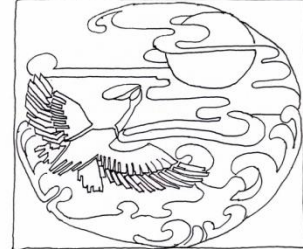
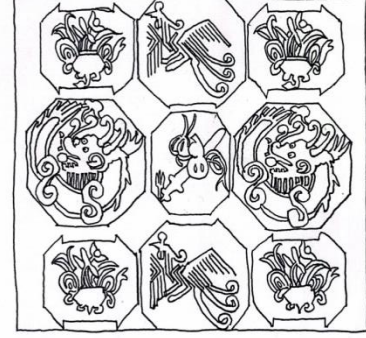
<p>A basket of flowers</p>	<p>The Zhuang people believe that the "flower woman" is the goddess of birth, and that flowers are the source of all things, and the unity of flower people. All the people in the world are a flower in the back garden of the flower woman. People to the flower woman "for the flower", the flower woman took out a flower from the basket to worship, and protect its smooth birth, children healthy growth.</p>	
<p>He xiang</p>	<p>thrush is the most noble kind of birds, which is often associated with the gods. It is a symbol of longevity, auspiciousness and elegance."Crane flying" has the meaning of lofty ambition</p>	
<p>The four treasures of the dragon and phoenix</p>	<p>Dragon and phoenix dynasty four treasure Zhuang brocade pattern. The pattern of the four treasures of the dragon and phoenix dynasty is mainly formed by the traditional auspicious pattern. Some are the combination of dragon, phoenix, gourd, dragon is a divine animal; phoenix, in ancient totem era is regarded as a divine bird to worship, in</p>	

Table 13 Statistical table of traditional Zhuang brocade patterns

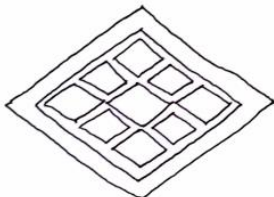
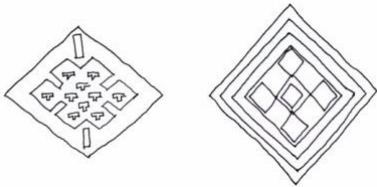
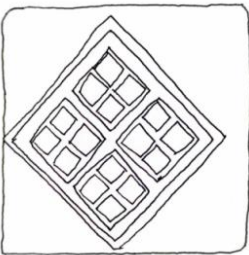
Source : Yaocheng Tian, Author : 17/January/2024

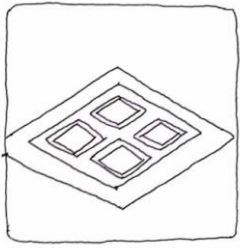
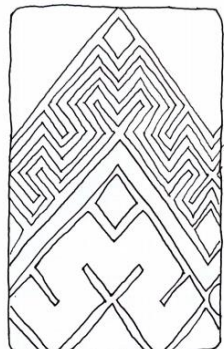
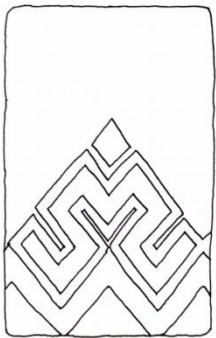
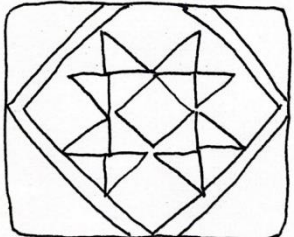
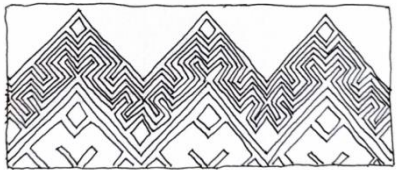
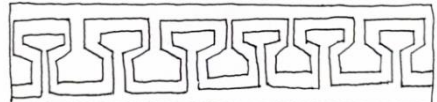


4.1 Traditional analysis of the 1 Guangxi Zhuang brocade patterns

Zhuang brocade Vivid patterns are the root of Zhuang brocade cultural inheritance. First of all, to brocadegxi, Binyang, Nanning and major museums, collect and organize Zhuang brocade traditional patterns, master the artistic characteristics and implication of Zhuang brocade patterns, for the innovation and development of Zhuang brocade patterns basic guarantee. Secondly, the collected traditional patterns were classified according to geometric lines, plant lines, animal patterns and text lines.

Geometry grain: there are diamond pattern, thousand knot, concentric knot, mud wall hole, four seasons peace, worship grain, flame pattern, octagonal star pattern, belt mountain pattern, water pattern, sawtooth grain, cloud thunder pattern, back pattern, copper grain (Table 14).

Geometry	implied meaning	case
Diamond pattern	Diamond pattern can be infinitely expanded to the square continuous, nine nine to one, meaning continuous.	
Thousand knot	Thousands of knots represent unity and happiness, peace and auspiciousness, can also be cited to strong feelings, tightly tied together, never separated.	
The mud wall hole	The mud wall hole of the zhuang houses. In the old days, the dwellings of the Zhuang nationality were mostly built of mud and grass, and the wall holes were kept as Windows. When young men and women use folk songs to courtship, because shy dare not meet directly, inside and outside, through the hole to peep at each other in the wall.	

Four seasons peace	This pattern is usually used on the pillow towel used for marriage. The four diamond patterns represent the four seasons of the year round, wishing the people on the pillow peace in the four seasons.	
To worship grain	Husband and wife worship, on behalf of the new expectations of the future life hope to love each other in the future.	
Flaming lines	The burning flame, like two hot hearts interwoven together.	
Octagon star grain	The octagonal star pattern shows the radiant sun, and the radiant star anise means that the square in the middle of the endless sky symbolizes the earth, with the meaning of the round sky and the place.	
Tiny mountain pattern	This pattern is a common edge pattern of Zhuang brocade. The endless mountains are often regarded as dragon veins with good feng shui.	
Water wave	The image of water ripples is to simulate the form of water flow, adding a sense of soul to the Zhuang brocade.	

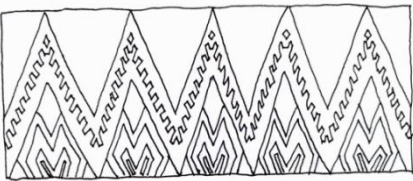
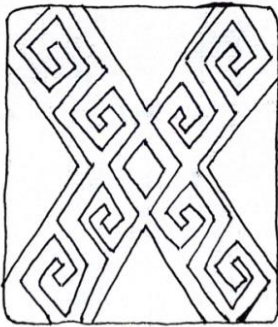
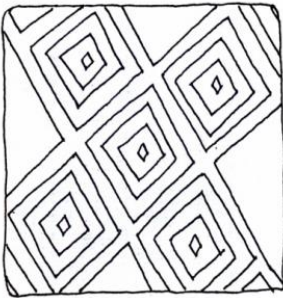
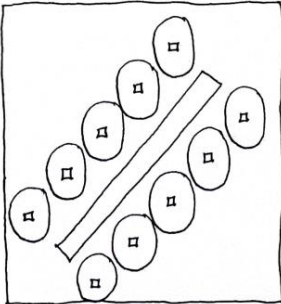
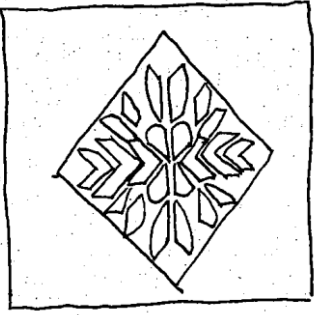
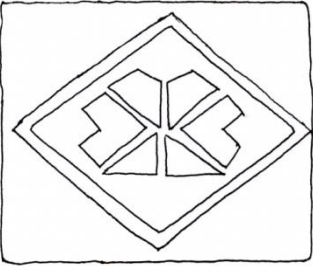
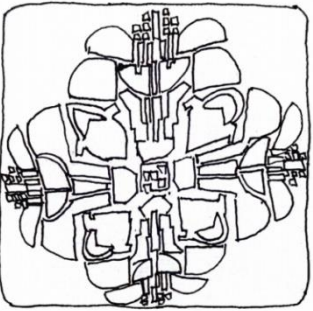
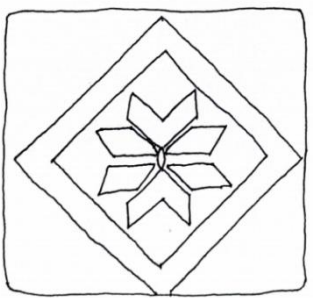
Saw tooth grain	The serrated grain is like a serrated grain, with the shape of a large saw and a small saw, which is an auxiliary edge pattern commonly used by Zhuang brocade, similar to water ripples.	
Cloud thunder grain	Cloud thunder pattern is the traditional pattern of Zhuang brocade, showing square twists or circular curved curly lines, looking like cloud roll cloud shu. This pattern is mostly used for decoration, but it is more used as the role of the skeleton-like separation area.	
Fret	Back pattern such as the word "back", hence the name, back pattern and cloud thunder pattern identical and synonymous.	
Copper money grain	Copper coins for the ancient currency, circular square hole, people usually string copper coins into a string of easy to carry. Zhuang brocade The use of copper coin string pattern, meaning to wish wealth, bonanza.	

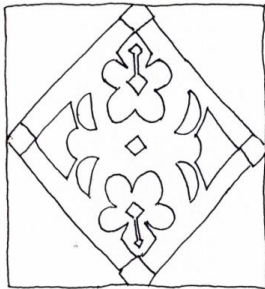
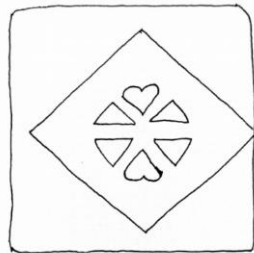
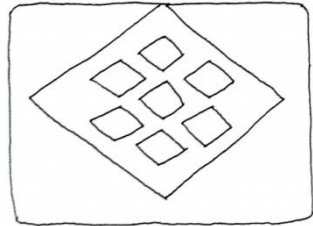
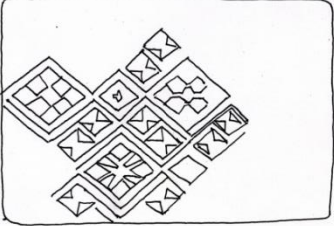
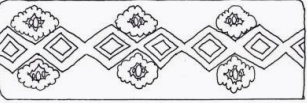
Table 14 Zhuang brocade geometric pattern statistical table

Source : Yaocheng Tian, Author : 17/January/2024

พหุบัณฑิต ชีวะ

Plant patterns: there are chrysanthemum, wild rose, kapok, star anise, hibiscus, peach blossom, plum blossom, osmanthus, wild strawberry, ribbon tree pattern (Table 15).

Plant grain	implied meaning	case
Chrysanthemum grain	All things grow by the sun, the sun has become the source of human survival and reproduction, is also the most primitive worship of human beings. The chrysanthemum pattern in Zhuang brocade symbolizes the sun's rays.	
multiflora rose	Wild rose, a common wild flower in southwest China, hillside, roadside, field edge everywhere, in May and June when the blooming mountains, bright and dazzling. In the old days, young men and women of the Zhuang nationality liked to sing beside the flowers, sometimes to express their love.	
kapok	Kapok is a unique tree species in the south, the trunk is strong and tall, indomitable posture, kapok color red as blood, also known as "hero flower". Cotton wool in the kapok fruit can be used as a pillow, quilt and other fillings.	
Octagon fruit	octagonal fruit is one of the important economic tree species in southwest Zhuang region. Star anise is a famous spice and can also be medicinal.	

Zhu brocadehua	Kapok is a unique tree species in the south, the trunk is strong and tall, indomitable posture, kapok color red as blood, also known as "hero flower". Cotton wool in the kapok fruit can be used as a pillow, quilt and other fillings.	
Peach blossom grain	Peach blossom is a traditional flower, a symbol of sweet love, but also used to praise the woman delicate and lovely.	
Plum blossom grain	People regard the plum blossom as the first of the four gentlemen in the flowers, one of the three friends of the cold, not with flowers, not afraid of cold, noble, strong and unyielding quality. Plum blossom also has the meaning of smooth, peace, happiness and luck, and is also regarded as a auspicious symbol.	
Osmanthus grain	Osmanthus generally blossom in August, flowers open four petals, white, light yellow, yellow, orange and so on. Osmanthus taste is very fragrant, clear can be the dust, thick can be far overflow, smell its fragrance can be refreshing.	
wood strawberry	Wild strawberry, a common wild fruit in southwest Zhuang area, sweet and sour taste, old material shortage, often to satisfy hunger or eaten as fruit. As a result, clusters of tapirs, a single fruit is the size of a little finger. From the result to maturity, the color changes	

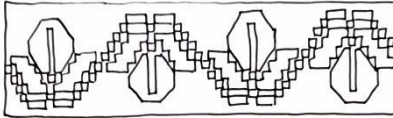
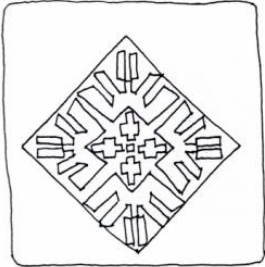
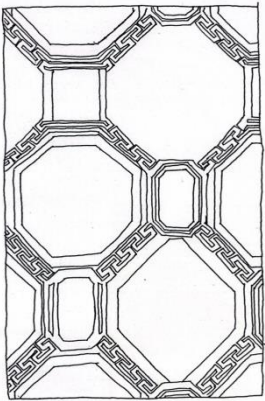
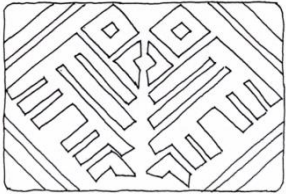
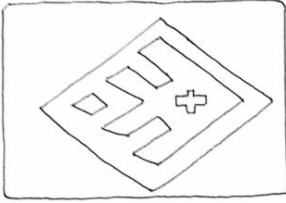
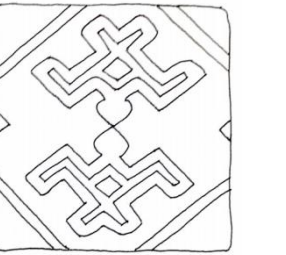
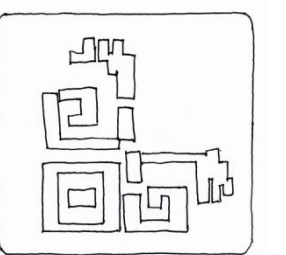
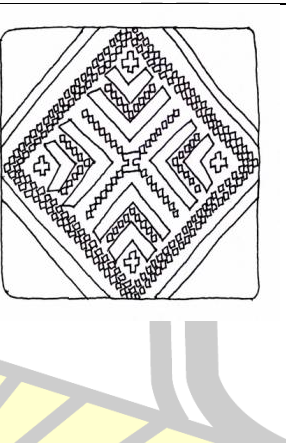
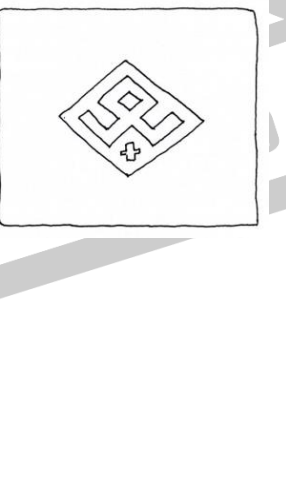
Belt pattern	tree	Tree stick figure pattern, Zhuang brocade common decorative pattern.	
--------------	------	--	--

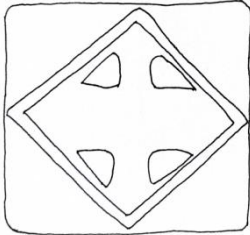


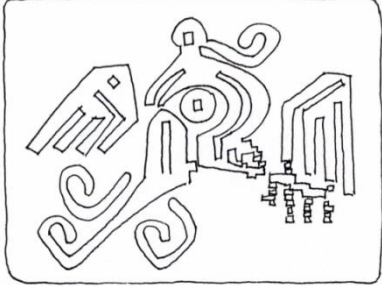
Table 15 Zhuang brocade, statistical table of plant patterns

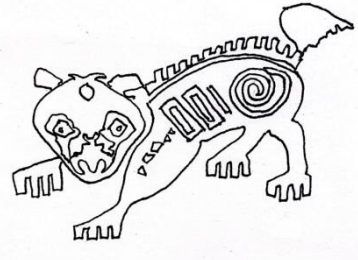

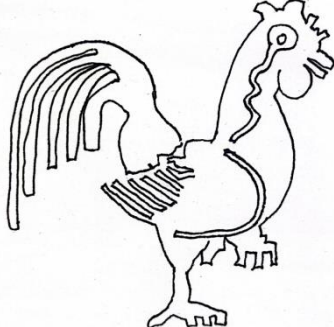
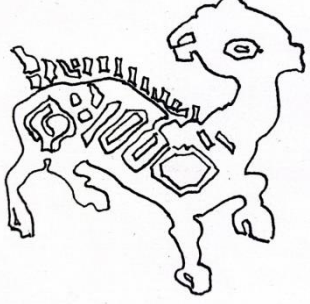
Source : Yaocheng Tian, Author : 17/January/2024

Animal pattern: there are swallow pattern, python dragon pattern, double fish pattern, fish pattern, dove pattern, butterfly pattern, four fish pattern, frog pattern, horseshoe pattern, dragon pattern, phoenix pattern, phoenix bird pattern, unicorn pattern, lion pattern, rooster pattern, god deer pattern, auspicious heron pattern (Table 16).

Animal grain	implied meaning	case
Swallow grain	Four yan to nest. Swallows is one of the common migratory birds, like to build nests in the eaves, have the habit of winter migration, and will return to the original place after the return. Therefore, swallows have the friendship of nostalgia, and people will think that it will bring good luck and wealth.	
Python dragon grain	Python dragon pattern traditional Zhuang brocade pattern. The python dragon pattern mainly takes the geometric pattern as the theme to decorate the pattern, and at the same time adopts the two continuous and square continuous composition method. The hexagon in the main pattern simulates the pattern pattern on the python body, so it is named the python dragon pattern. The python dragon pattern in Zhuang brocade is often used in shawls and pendants.	
Double fish grain	Two "fish" hieroglyphic ancient characters, so the name double fish feet	

Fish pattern	Stick figure shape of the fish."Fish" and "Yu" are often implied as "like a fish in water" is also compared to a harmonious and happy work and life, but also a symbol of wealth. Happiness is free.	
The turtledove grain	Two turtledoves fly opposite them. Turtledove is a common bird in the Zhuang nationality, symbolizing long and unchanging love or friendship.	
Butterfly lines	Traditional butterfly stick figure pattern. Butterfly flying is a good life scene and is often considered a symbol of good love.	
Four fish grain	In the art and decoration of zhuang nationality, fish feet has always been an important symbol and element. This pattern not only reflects people's awe and appreciation of nature, but also carries rich cultural connotation and symbolic significance. Among them, "four fish feet combination" and "fish graph" synonymous, are common forms of expression.	
Frog grain	Stick figure figures of ancient frogs. Frog is the worship totem of the Zhuang people. Zhuang people believe that "frog" is the son of Lei Gong. There is a saying that "frogs call, thunderstorms come". Frogs can not only predict wind and rain, but also catch pests. Frogs lay a lot of eggs each time, so they have the wishes of many children and children. Traditional frog pattern weaving and embroidery pattern. With	

	<p>frogs as the theme, the body characteristics of frogs. The frog patterns woven by different ethnic groups in Guangxi are slightly different.</p>	
Horseshoe grain	<p>The four black dots in the picture are like the horseshoe print, meaning "the horse step": Yu steady horse step, down-to-earth.</p>	
Dragon design	<p>The dragon symbolizes power, nobility and honor. In the royal family, the dragon represents dignity and authority. Dragon pattern appears in the folk Zhuang brocade face, represents "the hope that the children can be promising. Get ahead and do a career.</p>	
Feng grain	<p>Phoenix is the lucky bird in people's hearts, a symbol of world peace. Phoenix is also a symbol of the imperial power, often used together with the dragon, phoenix belongs to the dragon, used for the empress and concubines, is the most noble woman. Phoenix lines appear in the folk Zhuang brocade is face, on behalf of "hope at the female phoenix", hope the girl auspicious, happiness, noble, life carefree.</p>	
Phoenix bird grain	<p>The phoenix bird is the totem of the Chinese nation, and the ancestors of the Zhuang people have the phoenix bird totem worship since ancient times. In the Zhuang myth, the "phoenix bird" is the "bird head" and the phoenix is the "king of birds", which is an auspicious omen and a symbol of a happy life.</p>	

Kirin grain	"Kylin send son" is the folk believe that kylin is the beast of benevolence and righteousness, is a symbol of auspiciousness. Chinese qi zi custom. Ancient legend for the lin to have children.	
Lion grain	Zhuang brocade The lion pattern means strength, courage and authority. The lion symbolizes courage and strength, praying for peace and prosperity. Zhuang brocade The lion pattern is not only a decorative pattern, but also a symbol of power and blessing.	
Male chicken grain	"Chicken" for "ji" homophonic, on behalf of auspicious. At the same time, the rooster dawn means dawn, symbolizing the departure of darkness and the arrival of light. The rooster also symbolizes trustworthiness and punctuality.	
The deer grain	There is a legend of "the deer leads the way" in the Zhuang people. The soul should guide the deer to heaven, otherwise they will get lost. In ancient times, deer were regarded as gods, and they were believed to bring happiness and longevity, and also a symbol of health and love. Also means a smooth journey, accessible in all directions.	

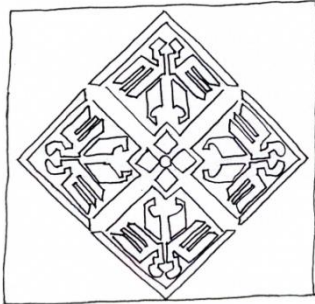
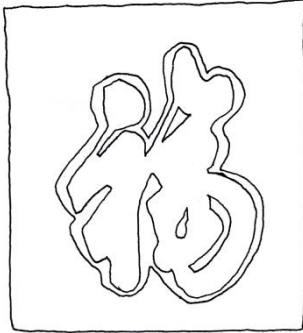
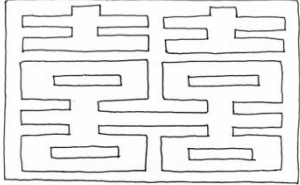

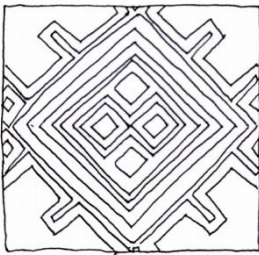
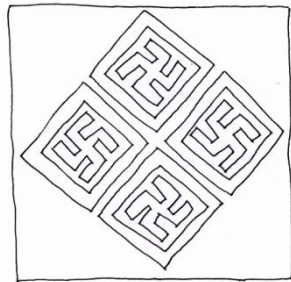
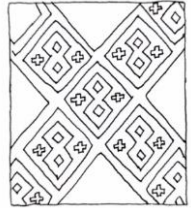
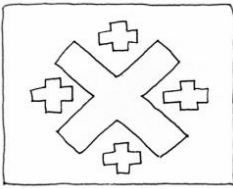
Xianglu grain	The picture shows a combination pattern of four pairs of herons. Heron, the birds who often fish by the river. "Through the" road ", a symbol of the road, official career. There is a way of glory, good luck, official career smooth meaning. Therefore, the heron is also known as the "auspicious heron"	
---------------	--	--

Table 16 Zhuang brocade, animal pattern statistics table
Source : Yaocheng Tian, Author : 17/January/2024

Text grain: there are fu character grain, happy word grain, longevity word grain, field word grain, king word grain, ten thousand word grain, 8 word grain, rice word grain, well word grain, king field grain, etc. (Table 17).

Text lines	implied meaning	case
Fu grain	Zhuang brocade The word pattern means happiness, auspiciousness and blessing. The Chinese character fu is one of the most common auspicious symbols in traditional Chinese culture, representing happiness and auspiciousness. Zhuang brocade The fu character pattern is usually used in festival decorations, traditional costumes and folk artworks, implying a prayer for happiness and blessings. This pattern often appears during the Spring Festival, weddings and other important occasions, bringing auspicious and good wishes to.	
Xi word grain	"Double happiness" pattern is the most common pattern of Zhuang brocade Chinese character auspicious pattern, which is used for wedding products to wish a happy marriage.	

Shou word grain	Longevity pattern of the traditional Zhuang brocade pattern. Generally, the longevity pattern in Zhuang brocade is composed of the word "longevity" of the oracle bone style as the main body, and the lace is composed of ten thousand words, or lines, rice lines, geometric lines and so on.	
Tian character grain	The field are like fields of farmland. Human beings entered the era of farming, the field is the most important property of a family, the number of fields represents the wealth and status of the family.	
A swastika pattern	Wanzi is an ancient and mysterious symbol popular in many countries and nations. Wanzi lines are simplified and deformed by octagonal star pattern, and the four directions are shaped. A symbol of the solar cycle, the replacement of the seasons, hope that children are healthy, children continue.	
The 8-word grain	8 word pattern such as "8" character, so the name, and the pattern, cloud thunder pattern identical synonymous.	
Rice character design	Food is the day of the people, rice for the people's food. Rice word appears in Zhuang brocade, meaning people's attention to food and the expectation of abundant food and clothing.	

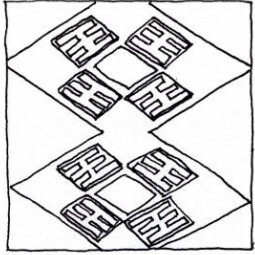
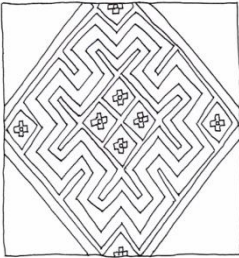
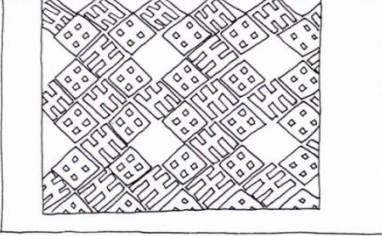
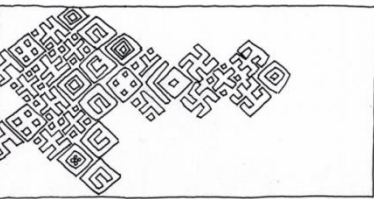
Wang character grain	Wang "is the supreme ruler of the feudal society, the ancient people believed that" wang " can connect through the heaven and earth, let people and heaven and earth natural harmony. Zhuang brocade The word "king" appears on it, indicating that the people who hope to be blessed have extremely high wisdom and ability, and are elected as "king" by the people of the world	
Well grain	word brocade character is a very ancient pictographic character, which records the changes of Chinese history and culture. From the "trap" of ancient hunting to the "well" of farming culture, it shows the settled farming culture and expresses the meaning of "thriving people".	
Wang grain	Tian The field is the symbol of the ancient territory of the king. The field somewhat represents the power of a king, and it is also the fief of the ruler, given to his relatives and servants. Therefore, "king" and "tian" will often appear at the same time.	
Combination of Chinese characters	Zhuang brocade The use of Chinese characters in the pattern reflects the zhuang people's acceptance of and continuous creation of foreign culture, and reflects the harmony and unity of the Zhuang people and all ethnic groups.	


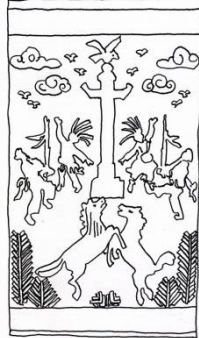
Table 17 Zhuang brocade, text pattern statistical table

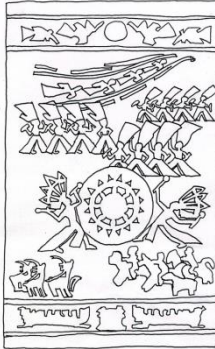
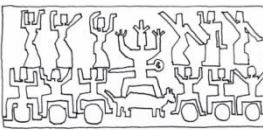
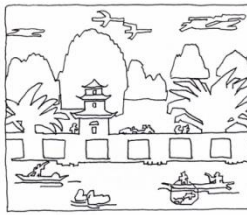
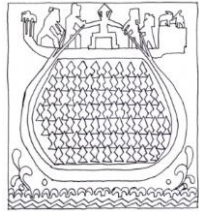
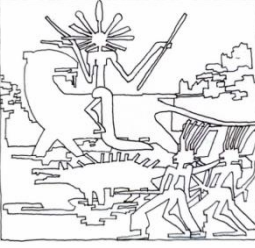
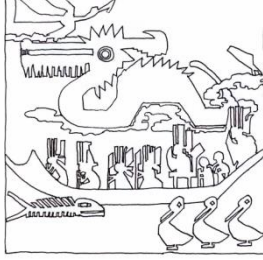
Source : Yaocheng Tian, Author : 17/January/2024

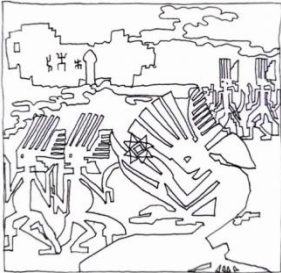

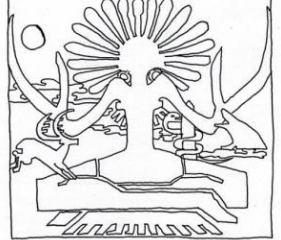
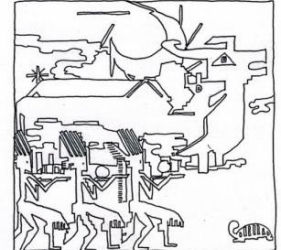
Zhuang brocade Colorful decorative pattern is brocade people with the most direct perspective, through the observation of life and nature and true, good and beauty of the sincere heart to express sincere praise to nature and life, the design artistic inspiration rooted in Guangxi land between mountains and water, but also reflects the historical stage of zhuang ancestors ideology and cultural symbol (Zhao, 2017, P: 15).

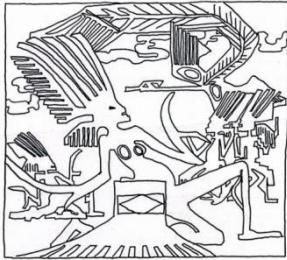
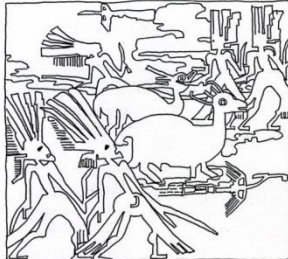

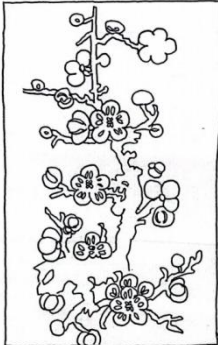
4.4 "traditional invention" analysis of Guangxi Zhuang brocade patterns

Reform and open to the outside world Later, the traditional patterns can no longer meet the needs of the society. As a folk art, Zhuang brocade first focuses on the innovation of the traditional patterns of the Zhuang nationality, and at the same time, it also absorbs other excellent artistic styles of the Zhuang nationality, such as Huashan rock painting form, farmer painting form, bronze drum pattern, etc., to strengthen the national characteristics of Zhuang brocade. In addition, the invention of Zhuang brocade pattern has the following characteristics: first, the use of Zhuang brocade changes to promote the invention of new patterns; the second, professional designers and folk artists participate in the innovation of Zhuang brocade pattern; the Zhuang brocade pattern invention, which strengthens the era, nationality and commodity; the Zhuang brocade pattern and the Zhuang epic or cultural symbols of zhuang. Innovation Zhuang brocade pattern include: liu sanjie, horse, tonggu, festival harvest, old state landscape scenery, harvest fish, play, rhyme, reproduction, ancestor worship, great trust, cow soul, feather, ecstasy, drum, huashan, plum, orchid, bamboo, chrysanthemum and other new patterns (Table 19), make Zhuang brocade design conception profound meaning, pattern gorgeous, more rich and colorful, embodies the zhuang people's love and pursuit of a better life.

Innovation pattern	implied meaning	case
Three elder sister liu	Liu Sanjie Zhuang brocade symbolizes the diligence, wisdom, beauty and kindness of the Zhuang people, and also carries the historical and cultural deposits of the Zhuang people.	
The horse	The Zhuang brocade symbolizes the courage, strength and unity of the Zhuang people. The elements of the horse, the lusheng and clouds represent the production and life style, religious belief and spiritual worship of the Zhuang people, as well as their expectations and yearning for a better future.	

Bronze drum	Bronze drum is a bronze ware of special social significance for the southern minorities in ancient China. It is a symbol of power and wealth. Zhuang brocade It integrates the elements of the bronze drum and records the Luoyue culture with a long history in China.	
Happy harvest	The combination of people and objects, the picture of men hunting, women singing and dancing, depicting the scene of celebrating together after the harvest.	
Old state landscape scenery	This picture weaves the beautiful scenery of Jiuzhou into Zhuang brocade to express the feelings of brocade gxi Zhuang people's love for their hometown.	
Harvest fish	This picture depicts the picture of the boat fishing harvest, expressing the joy of the harvest.	
Go out to fight the enemy	Although the living conditions of the Zhuang people are very poor, they are not eliminated by the bad living conditions. They overcome nature, overcome nature and get close to nature. This is the charm of the ancient yue wind.	
Water rhyme	Because the Zhuang nationality is a rice-making nation, they are good at water and geographical environment factors, people have been inseparable with water for a long time, and also have the worship of the god of water. This is a scene of the god of water, hope the god of water does not drop flood, fish and rice harvest.	

Multiply	At the same time, people struggled to survive in the harsh living conditions. This is the worship of reproduction and the worship of the Zhuang ancestors. They hoped to get the blessing by god by offering sacrifices to the gods, so as to achieve the beautiful willingness of strong people and a strong nation.	
Ancestor worship	The scene of ancestor worship. The bird symbolizes auspiciousness, and people put it on a very high position and worship it together with the souls of their ancestors. The feather people on the brocade and the sacrificial scenes on the rock wall both reflect the worship of the ancestors of the Western Vietnamese people.	
Great trust	In the image of a western Vietnamese national tribal leader, people put all their hopes on him, he is the "sun" on the earth. However, his dry eyes looked up at the sky. After all, he was a man rather than a god, lifting the heavy sun and the moon with his hands and the wishes of the whole nation.	
Bull soul	Cattle is an important basis of rice farming culture, a totem of the Western Yue nation, and a symbol of wealth and strength. Our ancestors were born with a special love for the cattle. In order to show their love for cattle, the ancestors of the Zhuang people used zongzi, eggs and dumplings to sacrifice cattle in the "Cattle Soul Festival". People lived in harmony with cattle and cannot do without cattle at any time.	

Yu people	<p>Yu people are the worship totem of the Zhuang people, the flying fairy in the myth, the direct expression of the ancient workers' yearning for freedom and light, and the pursuit of light by the ancestors of Luoyue. People in the phoenix than beauty, their clothes and headdress, are decorated with bird feathers, dance to be more beautiful than the phoenix.</p>	
Wild with joy	<p>After hunting, people danced with their prey, but also pleased the gods of animals, hoping that god would give more prey, which reflects the production and life scenes of the ancestors of Xiluo.</p>	
Drum wei	<p>It is said that the bronze drum can eliminate disaster. When people beg for rain, heaven and god, they will sound the powerful and rugged bronze drum. People beat the skin drum and drum drum, I do not know that heaven has seen the suffering of the nation.</p>	
Prunus mume	<p>Plum blossom symbolizes auspicious, strong, it is not afraid of the cold weather, resolutely bloom in the cold winter. Plum blossom usually opens in the twelfth lunar month, and there is a saying of "plum blossom for spring". After the winter, warm spring will come after the good meaning.</p>	

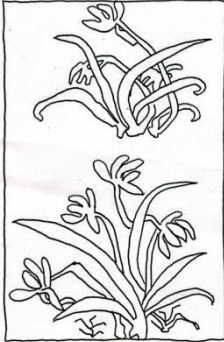
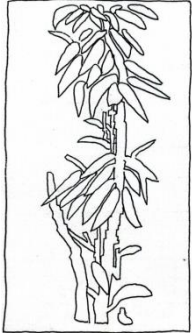
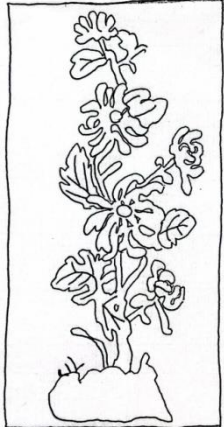
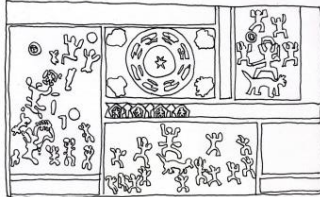
Orchid	Orchid is noble and elegant, known as "the gentleman of flowers ". Orchid symbolizes excellence and beauty, perseverance and deep friendship.	
Bamboo	Bamboo evergreen is a symbol of tenacious life, bamboo festival exposed is a symbol of high wind and integrity. Also take the bamboo newspaper peace and peace high meaning.	
Chrysanthemum	Chrysanthemum is one of the gentlemen in the flowers, with auspiciousness, integrity, longevity and purity.	
Huashan pattern	Huashan pattern Zhuang brocade pattern. Zhuang brocade The huashan pattern on it is a part of the content on the flower mountain rock mural, woven and embroidered on the cloth, with strong Guangxi color.	

Table 18 Zhuang brocade, innovative pattern statistical table

Source : Yaocheng Tian ,Author : 17/January/2024

For example, brocadegxi Zhuang brocade Factory constantly tries to extract cultural symbols from Zhuang traditional culture to enrich the theme and patterns of Zhuang brocade. One of the groups of Yuefeng Zhuang brocade works is typical of the effective combination of zhuang traditional themes and modern pattern design. It is the result of Zhuang brocade's successful cooperation between Li Cunling and Zeng Dan 20 years ago. Zeng Dan is an art teacher at a middle school in brocadegxi. He has rich experience in pattern design. The design originated from Zeng Dan's trip to Beibrocadeg, and received amazing decorations with ethnic characteristics, such as the wall hanging from Senegal to participate in Beibrocadeg. They felt that their own material were rich, but not fully excavated. Traditional Zhuang brocade is basically a daily product composed of repeated patterns with auspicious meanings, which can no longer meet the aesthetic needs of modern people. Now, Zhuang brocade is a painting with cultural meaning (Lu & Zhang, 2020, P: 87). In terms of the pattern innovation of the Yue Wind series Zhuang brocade, the Yue Wind Zhuang brocade works retain the traditional geometric patterns and animal patterns while adding and highlighting the character patterns. Among them, "Fight", It is the heroic spirit of the zhuang ancestors fighting against the harsh natural environment; "Water rhyme" is the scene of zhuang ancestors sacrifice to the god of water; "Reproduction" shows the worship of the Zhuang ancestors; "brocadeg Zu" shows the scene of zhuang ancestors sacrificing the ancestors and praying for blessing on the cliff; "The Great Trust" shows a tribal leader of the Zhuang ancestors who lived up to expectations, The courage to hold up the responsibility image of the sun and the moon; "Bull Soul" is the performance of zhuang ancestors in the Niu Soul Festival with reed rice, eggs and glutinous rice cake cattle scene; "Feather people" is the performance of the zhuang ancestors dressed in feather clothes and the phoenix competition beauty scene; "Ecstasy" shows the joy of the zhuang ancestors returning from hunting; Drum Wei reflects the bronze belief of the ancestors of the Zhuang people (Wu, 2021, P:28). These patterns are not only rich in national characteristics, but also have a profound cultural connotation, showing the life, belief and values of the Zhuang ancestors. The pattern innovation of Zhuang brocade is not only the inheritance of traditional culture, but also a unique contribution to modern society.



Part V: Guangxi Zhuang brocade The "traditional invention" practical exploration

This section studies the analysis of the Guangxi Zhuang brocade "traditional invention" practice exploration. It is divided into two parts, the first is the Guangxi Zhuang brocade "traditional invention" practice; the second is the Guangxi Zhuang brocade "traditional invention" recommendations.

5.1 Guangxi Zhuang brocade "traditional invention" in practice

(1) Government-led practice

Traditional Zhuang brocade has always been a necessity for the life of the Zhuang people, but since reform and open to the outside world, under the impact of cheap goods, the living space of traditional Zhuang brocade has been rapidly dissolved and quickly withdrawn from the daily life of the Zhuang people. Until 2006, when the brocade Guangxi Zhuang brocade technique became a national intangible cultural heritage, Zhuang brocade became more and more prominent as a unique cultural symbol of the Zhuang people, becoming a symbol of the Zhuang people and Guangxi Zhuang Autonomous Region. therefore, The government has led the practice of Zhuang brocade traditional invention from the following three aspects: First, To a giant Zhuang brocade, Major activities within the country or within the autonomous region, In the form of gifts with the giant Zhuang brocade on display at major events, Thus, creating new symbols of the Zhuang people and the Guangxi Zhuang Autonomous Region through Zhuang brocade, At the events of Expo 2010, The People's Government of Guangxi Zhuang Autonomous Region has adopted the Guangxi Zhuang brocade Exhibition for the World Expo, As a gift to the Shanghai World Expo, At the same time, the big wall hanging also won the Guinness record for the largest Zhuang brocade, It further strengthens the symbolic significance of Zhuang brocade; second, Since 2006, After the zhuang brocade art was awarded the national intangible protection project, Zhuang brocade From the skill of every household to a rare skill of the Zhuang people, More through the intangible cultural heritage Zhuang brocade is reshaped and invented a new identity; third, By shaping the connotation and invention of the Zhuang brocade culture, Create cultural inventions and dissemination closely related to Zhuang brocade, For example, Zhuang brocade, a large-scale musical launched by the Baise government in 2008, Shape the Zhuang brocade as the source of the zhuang people's pursuit of happiness, Lay a solid foundation for Zhuang brocade to become an important symbol of Zhuang culture.

(2) The Practice of Guangxi Zhuang culture brand

Zhuang brocade Although basically disappeared in the daily life of Zhuang people, as one of the representatives of Zhuang cultural symbols in Guangxi, Zhuang brocade is given the identity of cultural brand. Giving full play to the advantages of Zhuang brocade in zhuang customs, the government usually selects the handicraft — —Zhuang brocade with local characteristics of Guangxi as the official hand ceremony. Giant Zhuang brocade also presents gifts to the organizers on behalf of Guangxi. In addition, the pattern of Zhuang brocade is also widely used in major official events, making Zhuang brocade's brand culture surpass itself and become an important cultural brand in Guangxi.

(3) Zhuang brocade Cross-field practice

Zhuang brocade This is with the meaning of many auspicious happiness, Zhuang brocade is no longer a symbol of rural love, friendship, but in different fields Zhuang brocade according to the appropriate identity to adapt to the needs of society, such as Zhuang brocade as art installation in public space design, Zhuang brocade as a national product as tourism products, Zhuang brocade as clothing major folk activities, etc. This requires that Zhuang brocade is not a necessary skill for Zhuang women, but that Zhuang brocade technology needs to cooperate with experts in cross-border fields to expand the practice field of Zhuang brocade.

5.2 Guangxi Zhuang brocade "traditional invention" recommendation

(1) It is suggested to strengthen the use ceremony of Zhuang brocade construction

Eric Hobsbaum's analysis of "traditional invention" points out that the inheritance of tradition, ritual is the carrier of inheritance. Then how to effectively build the Zhuang brocade use ceremony in the modern context is a necessary link to invent the new Zhuang brocade tradition. We need to invent new use rituals according to the scope, time, place and space of modern Zhuang brocade use, combined with the existing major folk activities of the Zhuang people. In modern society, as a kind of handicraft with profound traditional culture, the innovative development of its use ceremony is of great significance. In order to better inherit and carry forward the Zhuang brocade culture, we can start from the following aspects:

First, excavate the cultural connotation of Zhuang brocade and innovate the form of ceremony: through the study of the history, legends, patterns and other cultural elements of Zhuang brocade, combined with the modern life style, to create a Zhuang brocade use ceremony with modern characteristics. For example, in major festivals in Guangxi, costumes with Zhuang brocade elements can be designed to show the unique style of the Zhuang people.

Second, combined with folk activities, enrich the content of Zhuang brocade ceremony: combined with the existing major folk activities of the Zhuang people, such as Buluotuo, March 3rd of the Zhuang Nationality, Nanning International Folk Song Art Festival, etc., combine these activities with the use of Zhuang brocade to make Zhuang brocade ceremony more rich in national characteristics. At the same time, experts and scholars can be invited to demonstrate and guide the use of Zhuang brocade patterns, to ensure the rigor and rationality of the use of Zhuang brocade patterns.

Third, the combination of pilot and promotion to test the effect of the ceremony: after the design of a new Zhuang brocade use ceremony, the pilot is first carried out in a small area to observe the implementation effect of the ceremony. On the basis of the pilot, the ceremony is adjusted and improved to ensure that it conforms to the pace of life and aesthetic needs of modern society. After the success of the pilot, the ceremony can be extended to a wider range, so that more people can understand and participate in the inheritance of Zhuang brocade culture.

Fourth, media publicity and intangible cultural heritage training to improve the visibility of Zhuang brocade ceremony: through various media platforms, such as TV, Internet, newspapers, etc., to promote Zhuang brocade ceremony, to improve the public's awareness of Zhuang brocade culture. At the same time, Zhuang brocade

cultural education should be carried out in various educational institutions, so that the younger generation can better understand and inherit Zhuang brocade culture.

Fifth, stimulate creativity and encourage innovation: hold Zhuang brocade cultural creative design competition, encourage people from all walks of life to actively participate in the innovation and development of Zhuang brocade culture, to provide a steady stream of ideas for the innovation and development of Zhuang brocade use ceremony.

Sixth, policy support to promote the development of Zhuang brocade industry: the government can introduce relevant policies to support the prosperity and development of Zhuang brocade industry, and provide a good policy environment for the innovation and development of Zhuang brocade ceremony. Through the implementation of the above suggestions, it is believed that the new use ceremony of Zhuang brocade will glow with new vitality and vitality in the modern society.

(2) It is suggested to create a Zhuang brocade living space in the city

With the pace of urbanization, China's mainstream consumer groups gradually gather in cities, which provides a new stage for Zhuang brocade, a national cultural treasure. It is not forgotten in the tide of modernization, but has gained a new vitality in the urban space in a new form, realizing a magnificent turn from the countryside to the city. Zhuang brocade This folk art, which carries a profound history and unique culture, has gradually emerged in the prosperity of the city. However, we must also admit that the symbolism of Zhuang brocade is somewhat affected along with the loss of the original folk environment. In order to better protect and inherit this treasure of national culture, it is necessary for us to carefully create an environment suitable for Zhuang brocade growth in the urban space."March 3rd of the Zhuang Nationality · Bagui Carnival" is an example worth learning from us. In this grand festival, all the citizens and tourists dressed in Zhuang brocade clothes can take the subway to each branch venue for free. Such measures have not only spread Zhuang brocade widely in cities, but also inspired people's love and respect for Zhuang culture.

In this way, we can not only make Zhuang brocade continue to thrive in the city, but also make contributions to the inheritance and promotion of China's excellent national culture. The government, enterprises and every citizen should make concerted efforts to provide necessary support for the inheritance and development of Zhuang brocade and other intangible cultural heritage in the city. Let us work together to let Zhuang brocade, a national cultural treasure, blossom more brightly in the city and leave a rich cultural heritage for our future generations.

พหุบัณฑิต ชีว

Summary

In the first part, the government attaches great importance to the shaping and dissemination of the Zhuang cultural symbol Zhuang brocade. Through the construction of national and district-level intangible cultural heritage protection, Zhuang brocade has been given a new status symbol and become the symbol representative of Zhuang culture. With the help of "a Zhuang brocade" folk story, promote the integration of Zhuang brocade culture and Guangxi opera, animation, music, opera and other diverse arts, make Zhuang brocade become the symbol of Zhuang people's pursuit of a happy life. In this process, the government not only enhanced the cultural value of Zhuang brocade, but also promoted the wide spread and popularity of the Zhuang people.

In the second part, as the outstanding representative of Zhuang culture and the symbol of Guangxi, giant Zhuang brocade is a milestone in the traditional invention process of Zhuang brocade tradition. By participating in major national and regional activities, Zhuang brocade has not only demonstrated its unique artistic charm, but also realized the leap from the folk to the international stage, creating a new context and space for use. This process not only highlights the innovation of Zhuang brocade technology and the development of patterns, but also lays a solid foundation for the dissemination and inheritance of Zhuang culture. Therefore, the giant Zhuang brocade is not only an important link in the practice of "traditional invention", but also an important carrier for the Zhuang culture to show its unique charm to the world.

In the third part, the production technique of Zhuang brocade has been developed in many stages. Its traditional loom is divided into four categories, including brocadexi brocade machine, bamboo cage machine, Huanjiang Zhuang brocade loom and dragon boat brocade loom. These looms have their own characteristics, which together reflect the profound cultural heritage of the Zhuang brocade skills. In order to improve the production efficiency, broaden the Zhuang brocade wide Zhuang brocade technology through the introduction of improved seed brocade machine. Under the promotion of the autonomous region government, the advent of innovative silk loom not only provides a solid foundation for the production of giant Zhuang brocade, but also promotes the new exploration, new practice and new development of Zhuang brocade fabric, showing the innovative vitality of Zhuang brocade technology.

In the fourth part, through fieldwork, the Zhuang brocade pattern design presents two major types: pattern type and pattern type, which are further subdivided into traditional type and invention type. Traditional patterns originate from Zhuang culture and ethnic life, while the patterns of new inventions are mostly created by modern designers or art professionals, with relatively little connection with life. In terms of pattern innovation, Zhuang brocade patterns incorporate folk art elements, such as bronze drum patterns, mountain rock paintings and farmer paintings and other composition forms, through which these patterns show the unique charm of Zhuang culture. As the driving force of Zhuang brocade inheritance for thousands of years, it must keep in touch with the past in the process of inheriting the tradition and innovation and invention, and cannot be fabricated out of nothing. Therefore, in the traditional invention process of Zhuang brocade, pattern design has formed a good interactive relationship with social needs and development.

In the fifth part of Guangxi Zhuang brocade, the government played a leading role. Through the promotion of giant Zhuang brocade, intangible cultural heritage and the story of a Zhuang brocade, the identity of Zhuang brocade as an important cultural symbol of the Zhuang people. At the same time, the government has also built Zhuang brocade into a cultural brand of the Zhuang people, further enhancing its cultural value. Zhuang brocade In the cross-field practice, Zhuang brocade has been introduced into many fields, opening up a new living space, which requires more cross-border cooperation and the participation of artists and professionals, in order to realize the living inheritance of Zhuang brocade. For Zhuang brocade traditional invention, it is suggested to build the use ceremony of Zhuang brocade to create a living space for Zhuang brocade in the city and provide a solid guarantee for the modern inheritance of Zhuang brocade. These measures will help promote the inheritance and development of Zhuang brocade culture, and let more people understand and appreciate the unique charm of Zhuang brocade.



CHAPTER V

Explore the social memory and traditional invention of Guangxi

Zhuang brocade through folk activities

This chapter answers to the fourth research goal. The fourth research goal is to study and analyze the "social memory" and "traditional invention" of Guangxi Zhuang brocade through folk activities. The concepts used in this chapter are "social memory" and "traditional invention". This chapter mainly discusses the "social memory" and "traditional invention" of Guangxi Zhuang brocade in the folk event "March 3rd of the Zhuang Nationality Bagui Carnival", which are divided into four parts. The first part is activity background; the second part is business nature; the third part is data analysis; and the fourth part is evaluation and discussion.

Guangxi Zhuang brocade As one of the important symbols of the Zhuang culture, it is frequently appeared in the Zhuang folk activities. Its emergence mode is divided into three categories. One is that, Zhuang brocade Display of the ontology, Such as the display of Zhuang brocade skills, Zhuang brocade display, Zhuang brocade clothing and cultural and creative products in folk activities; 12 It is, therefore, The display of Zhuang brocade's pattern, etc., For example, a large number of Zhuang brocade patterns are used in the background of publicity in folk activities, Zhuang brocade patterns are used in the activity atmosphere, and Zhuang brocade patterns are used in the activity-related design; 13 is, therefore, Zhuang brocade Display of the culture, For example, in folk activities, Zhuang brocade culture is often displayed in film and television segments, operas and songs. In the promotion of ethnic culture and folk activities, the government often chooses the folk activities with a sense of ceremony as the key support, while Guangxi Zhuang brocade should play three kinds of display power in the folk activities. Therefore, this paper chooses the folk activities "March 3rd of the Zhuang Nationality · Bagui Carnival", Analyze the "social memory" versus "traditional invention" of the Guangxi Zhuang brocade.

Part I: Activity background

1.1 Introduction and development course of March 3rd of the Zhuang Nationality

(1) Introduction of March 3rd of the Zhuang Nationality

March 3rd of the Zhuang Nationality, Also known as the Singing Festival, Songpo Festival or Singing Festival, is an important folk activity among the Zhuang people. In view of the differences in regional customs and habits, the festival is celebrated in colorful ways, mainly including traditional activities such as mountain worship, worship to the dragon mother, song gathering, the custom of seeking flowers and sending children, making five-color glutinous rice, the game of grabbing fireworks and touching eggs. This festival is a traditional festival with distinctive Zhuang cultural characteristics, which has been gradually evolved by the Zhuang nationality and its ancestors under the specific historical background and living environment. It is particularly worth mentioning that March 3rd of the Zhuang Nationality in Wuming District, Nanning City, Guangxi Province, as the representative celebration of the

festival, is mainly prevalent in Luobo Town, Liangjiang Town, Luwo Town and Matou Town in the eastern part of Wuming District, and Luowei Town and Lingma Town in the western part of Wuming District.

On January 13, 2014, with the approval of the People's Government of Guangxi Zhuang Autonomous Region, March 3rd of the Zhuang Nationality officially became a legal holiday in Guangxi. On November 11 of the same year, "March 3rd of the Zhuang Nationality", declared by Wuming District of Nanning City, Guangxi Zhuang Autonomous Region, was approved by The State Council of the People's Republic of China and was included in the fourth batch of national intangible cultural heritage list. This move marks the "March 3rd of the Zhuang Nationality" folk activities to the official activities in Guangxi, and into the process of "tradition of invention".

(2) March 3rd of the Zhuang Nationality Development history

March 3rd of the Zhuang Nationality The exact origin of the festival has not been conclusive results, but according to the existing historical documents, the festival may have a related relationship with the "Shangsi Festival" in the Central Plains of the Western Zhou Dynasty. Shangsi Festival occupies an important position in the festival system of the Han Dynasty. It is one of the five decrees respected by the Han Dynasty. The other four festivals were Shangyuan, La, solstice and Social Day. During the Han Dynasty, March was designated as a festival, among which the most iconic event was the ceremony held by the water. At the same time, the custom of holding grand banquets gradually emerged. However, after a period of prosperity from the Wei and brocade dynasties to the Tang Dynasty, to the Song Dynasty, the popularity of the "March 3 rd" festival began to gradually weaken. Related literature records and literary works of "March 3" mention is increasingly rare, the official attention has also declined sharply. With the passage of time, "March 3 rd" has gradually faded out of the cultural vision of the Central Plains. Although it is still preserved in some ethnic minority areas, its festival customs have been differentiated and presented strong local characteristics.

While absorbing the Han culture, "March 3rd of the Zhuang Nationality" also influenced each other with the "March 3 rd" of other surrounding ethnic minorities, and integrates the cultural characteristics of Guangxi, thus jointly forming the colorful "March 3 rd" culture of the ethnic minorities in Guangxi. "March 3rd of the Zhuang Nationality" is also known as the Song Wei Festival, written by the Song Dynasty in the zhuang nationality "men and women in costumes... party song". For thousands of years, the Zhuang culture has been innovated and developed through its long inheritance. At the same time, the main content is social interaction and love between men and women. After sacrifice or outing, young men and women play, tease, admire, courtship and love. Finally, give each gifts, or memorial, or affection.

In the Song Dynasty, Zhou Qufei had a record of "March 3" in the "volume ten": " the customs, Shangsi day, men and women meet, each for the ranks, with the five colors for the ball, song and throw, that fly. When the man and the woman marry, the woman and the man are married." March 3rd of the Zhuang Nationality The festival is rich and diverse, covering a series of activities such as mountain worship, worship to the dragon mother, singing ceremony, seeking flowers and sending children, making five-color glutinous rice, grabbing fireworks, touching eggs and so on. These activities not only show the profound heritage of the Zhuang culture, but

also carry the inheritance significance of multiple cultural epics. Specifically, they retain the original totem belief of the Zhuang nationality; they reflect the primitive worship of nature; the ancestor worship represented by Blotuo, which forms the spiritual core of March 3rd of the Zhuang Nationality festival and is passed on to this day. Fourth, as an important part of the excellent traditional culture of the Chinese nation, March 3rd of the Zhuang Nationality festival also highlights its unique cultural value.

1.2 Introduction of "March 3rd of the Zhuang Nationality · Bagui Carnival" activity

In 2014, "March 3rd of the Zhuang Nationality" was awarded as the national intangible cultural Heritage list. "March 3rd of the Zhuang Nationality" has become a unique minority festival in Guangxi. All kinds of celebrations emerge in endlessly, and its influence and popularity are constantly rising in the region and even the whole country. The Party Committee of Guangxi Zhuang Autonomous Region and relevant government departments have attached great importance to this unique cultural phenomenon and taken a series of effective measures to further promote and enhance its influence. In 2016, under the promotion of the government of Guangxi Zhuang Autonomous Region, innovative measures built "March 3rd of the Zhuang Nationality" into a "March 3rd of the Zhuang Nationality · Bagui Carnival" cultural tourism consumption brand integrating ethnic culture, mass sports, style tourism and characteristic consumption. It was decided that the government would build a platform for the public to participate in it and celebrate the traditional festival together. This move has undoubtedly injected new vitality and mission into the "March 3rd of the Zhuang Nationality", making it a more attractive and influential national cultural phenomenon, and attracting more and more tourists and people to participate in it, and experience this unique national cultural feast together.

From 2016 to 2023, the continuous "March 3rd of the Zhuang Nationality · Bagui Carnival" activity has successfully shaped a folk activity that meets the needs of the development of the modern society, and has become a folk activity with a long tradition in the modern society. therefore, Through the Guangxi Zhuang brocade and related cultures displayed in the "March 3rd of the Zhuang Nationality · Bagui Carnival", Analyze how Guangxi Zhuang brocade in the folk event "March 3rd of the Zhuang Nationality · Bagui Carnival", Redefining the "social memory" of Guangxi Zhuang brocade by Zhuang people and others, At the same time, it analyzes how Guangxi Zhuang brocade conducts "traditional invention" in folk activities(Figure 59).

พหุวัฒนธรรม ชีว



Figure 60 Display of Guangxi Zhuang brocade in the "March 3rd of the Zhuang Nationality · Bagui Carnival" over the years
Source: Yaocheng Tian 17/January/2024

Part II: Nature of the operation

March 3rd of the Zhuang Nationality · Bagui Carnival is a traditional festival celebration led by the government and widely absorbing the participation of folk enterprises and the masses. This activity is rooted in the profound cultural tradition of the Zhuang nationality in Guangxi, and is also widely valued and participated by the Han, Yao, Miao, Dong, am, Maonan and other ethnic groups in Guangxi. Through the innovation and development of March 3rd of the Zhuang Nationality, a traditional festival, we have effectively promoted the inheritance, protection and integration of various ethnic cultures in Guangxi, and further promoted the in-depth implementation of the cause of ethnic unity and progress. This move has played a positive role in strengthening the sense of community of the Chinese nation, and has become a clear example of building a common spiritual home for the Chinese nation.

2.1 social memory of "March 3rd of the Zhuang Nationality · Bui Carnival"

With the continuous deepening of reform and open to the outside world, "March 3rd of the Zhuang Nationality · Bagui Carnival" has built an operation mechanism led by the government and specifically undertaken by non-governmental organizations through the dual-track organization mode of cooperation by the government and the people. In the "March 3rd of the Zhuang Nationality" series of activities, the boundary between traditional folk art and folk customs is broken, and the innovative forms of openness, interaction, experience and communication are adopted to enable the people of all ethnic groups in Guangxi to experience and feel the traditional folk art and customs in the new environment and era background. This

series of activities has not only promoted the recovery of traditional culture, but also found a new living space for traditional culture in the new social environment, and left a deep social memory imprint for visitors, tourists and other people from all walks of life.

(1) Collective display of Zhuang folk art

In the "March 3rd of the Zhuang Nationality" activity, distinctive folk arts such as Liu Sanjie folk songs, Zhuang brocade skills, traditional wedding ceremony of Zhuang nationality, Zhuang Liao songs, Dong dage, Miao flying songs, Wuzhou Teng dance, five-color glutinous rice cake were displayed, so that the public could fully appreciate the charm of Guangxi Song hai. With history, literature, art and scientific value of national song and dance, clothing, folk, folk stunts, national food, national sports in the "March 3rd of the Zhuang Nationality" organic integration, a large number of Guangxi minority intangible cultural heritage not only exposed, also effectively inheritance and development (Gao, brocade & Huang, 2019, P: 4). In late April 2021, Xi brocade ping, General Secretary of the CPC Central Committee, went to Guangxi for an inspection visit. During this visit, he made a special trip to the Guangxi Museum of Nationalities to watch the display contents of the "March 3rd of the Zhuang Nationality" ethnic cultural activities and the exquisite performance of — — Zhuang brocade, a national intangible cultural heritage. Later, Comrade Xi brocade ping also communicated with Ms. Tan Xiangguang, a famous master of arts and crafts and the representative inheritor of Zhuang brocade skills at the autonomous region level (Figure 60).



Figure 61 Tan Xiangguang, a master of Chinese arts and crafts, performs the traditional Zhuang brocade manufacturing techniques

Source: <https://m.cnacs.net.cn/54/202104/2750.html> 17/January/2024

For example, in 2018, Guangxi Museum of Nationalities, as the main venue of "March 3rd of the Zhuang Nationality · Bagui Carnival", Show a picture scroll of national culture and customs: welcome guests and friends, 12 girls from Guangxi world nationalities formed a song array, 24 Mashan drum, 4 dun drum, 12 Lingyun trombone played a cheerful movement; Theme performance, Zhuang Xiang singing fair, bronze drum blessing, ethnic singing and dancing complement each other; Folk-customs experience, Zhuang, Yao, Miao, Dong, Mulam, Beibrocadeg and other traditional ethnic costumes, as well as pottery, weaving, peasant paintings, stone carvings, The site production of the Dong playing oil tea, Yangmei sand cake aroma overflowing, Traditional techniques melt on people's tongue.

(2) Experience of traditional folk-custom activities

On April 22, 2023, As one of the key activities of "March 3rd of the Zhuang Nationality · Bagui Carnival", the first China-Asean (Nanning) Intangible Cultural Heritage Week Activity Week (Figure 61), Held in Nanning Folk Song Lake Square, Gathering China Xinjiang Uygur Mukam art, Nanbrocadeg Yun brocade weaving skills, Fujian puppet show, And more than 150 intangible cultural heritage projects in 25 Chinese provinces (autonomous regions, municipalities), Laos Lusheng Music, Indonesian shadow Play, Thai Kong Opera, and Cambodian Royal Dance Drama, Let tourists feel the "festival customs" of different regions and different nationalities in the same cultural space. In addition, by holding intangible cultural heritage art performances, intangible cultural heritage fairs, China will actively explore cooperation in cultural heritage protection and utilization and cultural tourism brand building, so as to promote cultural exchanges and mutual learning between civilizations between China and ASEAN countries.



Figure 62 The first China-Asean (Nanning) Intangible Cultural Heritage Week activity Week

Source: https://www.gov.cn/yaowen/2023-04/22/content_5752729.htm#5
17/January/2024

In the celebration of "March 3rd of the Zhuang Nationality", singing folk songs and singing songs, as the core elements, always occupy an irreplaceable position. At the opening ceremony, the classic form of singing fair was continued, and people met friends with songs and spread feelings with songs, which not only showed the dialogue of ancient and modern culture, but also promoted the international exchange of songs, and the grand chorus of national unity. In addition, the international fashion elements with ASEAN characteristics not only highlight the new image of openness, inclusiveness and vitality of Guangxi, but also vividly present the joyful atmosphere of celebrating the "March 3rd" and the rich and colorful folk culture.

In the flow of time, the modern "March 3rd of the Zhuang Nationality" and the ancient "Shangsi Festival" have realized a perfect intersection, so that the national traditional culture can be inherited and developed in personal experience. In this event, tradition and fashion blend with each other, folk customs and trends collide with a wonderful spark, inheritance and innovation hand in hand. Among them, the "tide play" activity is the traditional culture and the depth of the modern life concept

fusion as the core, carefully set up the Guangxi wen gen tide play boutique display experience, brigade camping leisure life experience and Guangxi spring and summer tour routes, and other sections, bring participants brought new cultural experience and feelings.

In 2023 annual "March 3rd of the Zhuang Nationality · BaGui carnival" event, a series of elaborate Chinese traditional folk activities, such as boat leisurely sailing, water dance melody, beauty of elegant amorous feelings, children cuju lively scene and poetic painting, draw the outline of the ancient Chinese street life colorful picture scroll, deeply reproduces the han dynasty "SAN SAN" on the third festival, leading the audience through time, deeply experience "march" SAN SAN festival profound historical background and cultural heritage.

Through the "antique set" area of a delicate wall, the guests were led to play "fashion" plate, here brings together the children of China and asean countries, they hand in hand presents the street dance dynamic vitality, zhuang machine cool style and DJ show warm atmosphere, the event into a happy celebration across age and borders. The "Ethnic Unity" section begins with a traditional Zhuang wedding full of strong ethnic customs. The elderly dressed in gorgeous clothes extend their sincere wishes to the couple in Zhuang language. As the new couple completed the solemn and sacred "touch the egg" ceremony, a feast designed to promote the spirit of national unity and show the charm of diverse cultures was officially opened.

In addition, in 2023, Tan Xiangguang and Fan Lihua are busy with March 3rd of the Zhuang Nationality. Among them, Ms.Tan Xiangguang went to the teachers and students of Guangxi University of Mechanical and Electrical Engineering to carry out the lecture of "Inheriting Thousands of Skills, Weaving Colorful Life" with Guangxi Zhuang brocade (Figure 62), and Fan Lihua went to the activity site of "Meimei and Together to Build a Dream on March 3" (Figure 63) to guide the Zhuang brocade jewelry experience activity. Their participation in the activity shared the experience of Zhuang brocade culture with more than 1,000 people.



Figure 63 During the March 3rd of the Zhuang Nationality in 2023, Ms.Tan Xiangguang went to Guangxi University of Mechanical and Electrical Engineering to give a Zhuang brocade topic lecture

Source: Photo by Fan Lihua is provided by 17 / January / 2024



Figure 64 During the March 3rd of the Zhuang Nationality of 2023, the Fan Lihua girl guided the Zhuang brocade jewelry production

Source: Photo by Fan Lihua is provided by 17 / January / 2024

2.2 The tradition that the "March 3rd of the Zhuang Nationality · Bagui Carnival" was invented

In the process of discussing "traditional invention", "March 3rd of the Zhuang Nationality", a folk activity, is chosen as the object of analysis because of its profound cultural deposits and diversified functions. Traditionally, March 3rd of the Zhuang Nationality takes the singing party as the core and conducts social activities through singing, which is not only an important way of cultural expression, but also an important embodiment of community cohesion. In addition, the festival also integrates multiple functions such as sacrifice, trade and education in different regions, and is widely known as the Gewei Festival among the Zhuang people in Guangxi, reflecting its rich cultural connotation and social value.

Since the establishment of Guangxi Zhuang Autonomous Region, under the strong promotion of the government and the extensive participation of the people of the whole region, March 3rd of the Zhuang Nationality culture has been further developed and inherited. In this process, March 3rd of the Zhuang Nationality gradually showed the following advantages: First, in the 1950s and 1960s, the government actively shaped the image of Liu Sanjie, making it an indelible collective memory in the hearts of the people of all ethnic groups in Guangxi and even the people of the whole country. Second, with the deepening of reform and open to the outside world, the song fair activities are revitalized. In 1983, the People's Government of Guangxi Zhuang Autonomous Region officially announced that the third day of the third lunar month would be designated as the song Festival of the Zhuang nationality. And the first "March Third" song Festival was successfully held on April 16 in Nanning, which laid a solid foundation for the subsequent "March 3rd of the Zhuang Nationality · Bagui Carnival" activities. Third, in 2014, "March 3rd of the Zhuang Nationality" was officially established as a legal public holiday in Guangxi Zhuang Autonomous Region, and has been successfully selected into the national intangible cultural Heritage list. Fourth, in 2016, the People's Government of Guangxi Zhuang Autonomous Region further decided to launch the "March 3rd of the

Zhuang Nationality · Bagui Carnival", a public festival in Guangxi. With the joint efforts of the Guangxi government and people of all ethnic groups, "March 3rd of the Zhuang Nationality" has realized the magnificent transformation from the traditional Zhuang folk festival to the national intangible cultural heritage and then to the public festival in Guangxi, and become a unique symbol and image of Chinese culture created and shared by all ethnic groups. Therefore, the selection of "March 3rd of the Zhuang Nationality" folk activities as the research object has profound significance for the in-depth analysis of the "traditional invention" process and the social and cultural power behind it.

(1)The political orientation of the "March 3rd of the Zhuang Nationality · Bagui Carnival"

In 2016, the General Office of the Party Committee of Guangxi Zhuang Autonomous Region and the General Office of the People's Government of Guangxi Zhuang Autonomous Region jointly issued the "Work Plan on Building the" March 3rd of the Zhuang Nationality · Bagui Carnival "Tourism and Cultural Consumption Brand", With the principle of "government leading, social hosting, the masses leading, cultural mainstream" as the principle of activities, "Build 'March 3rd of the Zhuang Nationality · Bagui Carnival' into a collection of ethnic culture, mass sports style tourism and characteristic consumption, Extensive participation of the people of all ethnic groups in the region, National Culture Carnival with strong attraction to domestic and foreign tourists " (Fang, 2022, P:-10)."March 3rd of the Zhuang Nationality · Bagui Carnival" from the theme of the 70th anniversary of the founding of new China in 2019; The theme of fighting the epidemic in 2020, building a well-off society and forging ahead in the new era; In 2021, follow the theme of the Party; 2022 Welcome the party's 20th · the Chinese nation family theme; March 3 · New Era theme, Every year the theme is to follow the party closely, On this basis, "Guangxi wind" strong charm ", " meet to visit Guangxi ", " national sports dazzle ", " e network happy shopping "and" harmonic in Bagui " series of activities, Promoting the development of ethnic culture, trade and tourism, foreign exchanges and other aspects, It also enhances the sense of belonging, participation and happiness of the children of all ethnic groups."March 3rd of the Zhuang Nationality · Bagui Carnival" Zhuang traditional festival has been gradually transformed to all ethnic groups in Guangxi, and established in the form of local legislation, making it an important part of the work of local governments at all levels (Fang, 2022, P: 1-10).

พหุวัฒนธรรม ชีว

(2)The ceremony and symbol of "March 3rd of the Zhuang Nationality · Bagui Carnival"

First, organize a grand launch ceremony (Figure 64)



Figure 65 March 3rd of the Zhuang Nationality · Bagui Carnival in 2018

Source: <https://www.56-china.com.cn/show-case-2033.html> 17/January/2024

In order to further strengthen the influence of "March 3rd of the Zhuang Nationality", highlight the ritual sense of strong "March 3rd of the Zhuang Nationality". On the morning of April 27,2021, General Secretary Xi brocade ping, who was visiting Nanning, Guangxi, watched the exhibition of "March 3rd of the Zhuang Nationality" and "Song Wei Festival", and learned about the promotion of ethnic unity and progress and the protection and inheritance of ethnic culture (Figure 65).



Figure 66 On April 27,2021, President Xi brocade ping watched the "March 3rd of the Zhuang Nationality", "Song Wei Festival" and other ethnic cultural activities

Source: <http://cpc.people.com.cn/n1/2021/0427/c64094-32089674.html>

17/January/2024

With the theme of "March 3", the 2023 "March 3rd of the Zhuang Nationality · Bagui Carnival" opened in Qingxiu Mountain in Nanning. Liu Ning, secretary of the Party Committee of the Autonomous Region and director of the Standing Committee of the People's Congress of the Autonomous Region, and Sun Dawei, chairman of the CPPCC, came to the event to celebrate the festival with the people of all ethnic groups (Figure 66). They went to the representatives of the people of all ethnic groups and danced hand in hand in a happy dance, vividly demonstrating the profound friendship of the great unity of the Chinese nation and one family.

Guangxi Zhuang brocade It is mainly used in official cultural activities, and its purpose is mainly to identify the unique regional culture of Guangxi. For example, Liu Ning and Sun Dawei wear traditional Zhuang vests, collar and other places to use Guangxi Zhuang brocade to highlight its ethnic characteristics. It is in the special occasions and the sense of ceremony that Guangxi Zhuang brocade is embedded as a cultural symbol in the public cultural activities, and becomes a symbol of the image of the Zhuang nationality.



Figure 67 Liu Ning and Sun Dawei attend the opening ceremony of "2023 March 3rd of the Zhuang Nationality · Bagui Carnival"

Source: http://gx.news.cn/newscenter/2023-04/22/c_1129549241.htm
17/January/2024

Second, it highlights the symbol of special symbols

As a traditional folk festival, "March 3rd of the Zhuang Nationality" sacrifice, song fair and other festival activities have the nature of folk festival ceremony in a relatively fixed cycle and specific space, with a relatively unified ritual process, and the festival activities are full of symbolic significance. Guangxi "March 3rd of the Zhuang Nationality" uses the symbolic ceremony to stimulate and maintain the collective consciousness of the Zhuang people, deepen its social memory, and strengthen the unity and cohesion of ethnic groups (Wang, 2023, P: 1-146). New customs are not happen overnight, Needs a continuous and strong push, Organized under the leadership of the government, Rapid formation in Guangxi district level — city level — county level — township unified time, Launch the "March 3rd of the Zhuang Nationality · Bagui Carnival", Using unified slogans, activity signs, stage modeling, Guangxi Zhuang brocade cultural symbols, attending government representatives, costumes of the masses, etc., This is a comprehensive renovation of

the old March 3 festival, Become the new "March 3rd of the Zhuang Nationality". On April 25, 2018, Lu Xinshe, party secretary of the Autonomous Region, and Chen Wu, chairman of the Autonomous Region, jointly attended the "March 3rd of the Zhuang Nationality · Bagui Carnival" activity. During the activity, they had a cordial interaction with the people of all ethnic groups in Guangxi and wore Zhuang brocade scarves, which deeply implied that they were the leaders and representatives of the people of all ethnic groups in Guangxi. Therefore, "March 3rd of the Zhuang Nationality", a traditional festival, is no longer limited to the traditional singing party activities, but has become an important platform to fully show the diversity of Zhuang culture. At the same time, the campaign has also successfully shaped and strengthened the sense of national community, and further promoted the communication and integration among various ethnic groups (Figure 67).



Figure 68 Lu Xinshe (middle), party secretary of the Autonomous Region, and Chen Wu (second from right), chairman, celebrate the March 3rd of the Zhuang Nationality March 3rd of the Zhuang Nationality with people of all ethnic groups on April 25, 2018

Source: <https://www.56-china.com.cn/show-case-2033.html> 17/January/2024

(3) The "March 3rd of the Zhuang Nationality · Bagui Carnival" is connected with traditional customs

First, after the "March 3rd" song party was renamed as "March 3rd of the Zhuang Nationality", it was designated as a local legal holiday in Guangxi and became a national intangible cultural heritage activity, and the festival form and connotation of this folk custom have been significantly changed.

Second, "March 3rd of the Zhuang Nationality" breaks through the traditional entertainment form of song, and becomes a platform for the interactive display of many intangible cultural heritage in Guangxi, which contains more rich and diverse contents, and provides more resources for the inheritance of intangible cultural heritage protection and innovative development.

Third, the "March 3rd of the Zhuang Nationality" festival, which contains numerous Guangxi ethnic traditional customs, such as song wei, Zhuang brocade, bronze drum, hydrangea, Huashan rock painting, etc., appears in various forms of "March 3rd of the Zhuang Nationality · Bagui Carnival". The symbolization of various national cultures is a kind of refining, misappropriation and transformation of traditional national culture in contemporary social life, which is also the inheritance of tradition and traditional invention (Luo, 2019, P: 71).

Finally, Guangxi Zhuang brocade cultural symbols have been created by the Guangxi government. How to build a clear function of Guangxi Zhuang brocade in the new traditional "March 3rd of the Zhuang Nationality", such as a strong ritual system, which can be widely presented in festival activities, custom display, folk parade, stage modeling, story preaching and other activities. Therefore, Guangxi Zhuang brocade culture can be more close to life and integrated into the "March 3rd of the Zhuang Nationality" folk tourism project, so that tourists can enjoy the scenery, experience the local folk customs, but also experience the Zhuang brocade weaving skills, feel the unique ingenuity and temperature. Inheriting the Zhuang brocade culture. For example, Zhuang brocade cultural promoter LAN Peiwen performed "Zhuang brocade Exhibition" at the launch ceremony of "March 3rd of the Zhuang Nationality Bagui Carnival" cultural tourism brand series activities in Laibin City (Figure 68).



Figure 69 Zhuang brocade Cultural promoter LAN Peiwen performed "Zhuang brocade Show"

Source: <https://app5.cloudgx.cn/article/sync1650155423102074880>
17/January/2024

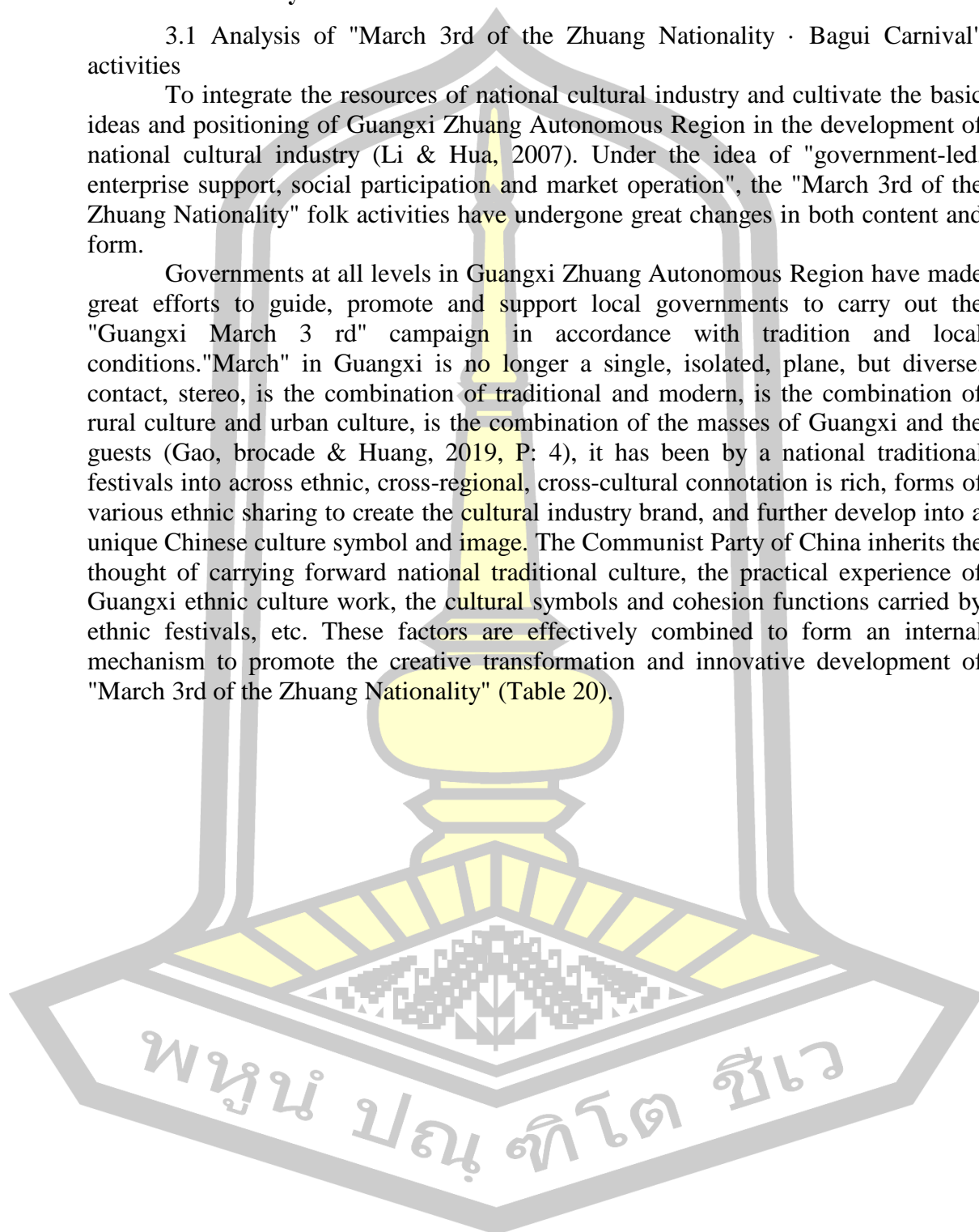
พหุ ม ประ โท ชี เว

Part III: Data analysis

3.1 Analysis of "March 3rd of the Zhuang Nationality · Bagui Carnival" activities

To integrate the resources of national cultural industry and cultivate the basic ideas and positioning of Guangxi Zhuang Autonomous Region in the development of national cultural industry (Li & Hua, 2007). Under the idea of "government-led, enterprise support, social participation and market operation", the "March 3rd of the Zhuang Nationality" folk activities have undergone great changes in both content and form.

Governments at all levels in Guangxi Zhuang Autonomous Region have made great efforts to guide, promote and support local governments to carry out the "Guangxi March 3rd" campaign in accordance with tradition and local conditions. "March" in Guangxi is no longer a single, isolated, plane, but diverse, contact, stereo, is the combination of traditional and modern, is the combination of rural culture and urban culture, is the combination of the masses of Guangxi and the guests (Gao, brocade & Huang, 2019, P: 4), it has been by a national traditional festivals into across ethnic, cross-regional, cross-cultural connotation is rich, forms of various ethnic sharing to create the cultural industry brand, and further develop into a unique Chinese culture symbol and image. The Communist Party of China inherits the thought of carrying forward national traditional culture, the practical experience of Guangxi ethnic culture work, the cultural symbols and cohesion functions carried by ethnic festivals, etc. These factors are effectively combined to form an internal mechanism to promote the creative transformation and innovative development of "March 3rd of the Zhuang Nationality" (Table 20).



a particular year	name	theme	time	Five modules and key activities	module	the number of showings of a film
In 2017,	March 3rd of the Zhuang Nationality · Bagu i Carnival		From March 20 to April 20th	5 large module activities	"March 3rd of the Zhuang Nationality · Guangxi wind strong rhyme" series of cultural activities "March 3rd of the Zhuang Nationality · Meet to visit Guangxi" series of tourism activities "March 3rd of the Zhuang Nationality · National Sports dazzle" series of sports activities "March 3rd of the Zhuang Nationality · e online happy shopping" series of activities "March 3rd of the Zhuang Nationality · Harmony in Bagui" series of activities	More than 1000 items
In 2018,	March 3rd of the Zhuang Nationality · Bagu i Carnival		On April 18-22	5 large module activities	"March 3rd of the Zhuang Nationality · Harmony in Bagui" "March 3rd of the Zhuang Nationality · e online happy shopping", "March 3rd of the Zhuang Nationality · Guangxi wind strong charm", "March 3rd of the Zhuang Nationality · Meet to visit Guangxi" "March 3rd of the Zhuang	More than 1000 items

					Nationality · National sports dazzle"	
In 2019,	March 3rd of the Zhuang Nationality · Bagui Carnival	The 70th anniversary of the founding of new China	From March 25th to April 25th	5 large module activities	"March 3rd of the Zhuang Nationality · Guangxi wind strong rhyme strong" "March 3rd of the Zhuang Nationality · Meet to visit Guangxi" "March 3rd of the Zhuang Nationality · National sports dazzle" "March 3rd of the Zhuang Nationality · e online happy shopping" "March 3rd of the Zhuang Nationality · Harmony in Bagui"	More than 1000 items
In 2020,	March 3rd of the Zhuang Nationality · Bagui Carnival	Fight the epidemic, achieve a moderately prosperous society and forge ahead in the new era	From March 26th to April 26th	5 modules, among which, in order to gather strength and boost consumption, this year "e online joy shopping" section is upgraded to "March 3 · Warm heart · Life Festival", and will continue to May 26	"March 3rd of the Zhuang Nationality · Guangxi wind strong rhyme strong" "March 3rd of the Zhuang Nationality · National sports dazzle" "March 3rd of the Zhuang Nationality · Meet to visit Guangxi" "Magnificent Guangxi March 3rd · Warm Heart Life Festival" "March 3rd of the Zhuang Nationality · Harmony in Bagui"	More than 1000 items
In 2021,	March 3rd of the Zhuang Nationality · Bagui Carnival	Feel the party grace Go with the party	From April 14th to May 14th	There are 35 major categories of key activities in the 5 major modules.	"Guangxi wind strong rhyme strong" "National sports dazzle" "Meet up to visit Guangxi" "E online happy shopping"	More than 1000 items

In 2022,	March 3rd of the Zhuang Nationality · Bagui Carnival	Welcome to the party's 20th grade The Chinese nation is one family	From April 2 to May 2nd	5 major modules, a total of 30 major categories of key activities	"Guangxi wind strong rhyme strong" "Meet up to visit Guangxi" "National sports dazzle" "E online happy shopping" "Harmony is in the Bagui"	More than 1000 items
In 2023,	March 3rd of the Zhuang Nationality · Bagui Carnival	The tide rises on March 3rd Endeavor in the new era	From April 1 to May 22nd	There are 41 major categories of activities in the 5 major modules. The autonomous region will carry out nine key activities	"Guangxi wind strong rhyme strong" "National sports dazzle" "Meet up to visit Guangxi" "E online happy shopping" "Harmony is in the Bagui"	More than 1,000 items.

Table 19 Information table of March 3rd of the Zhuang Nationality · Bagui Carnival activities over the years Source : Yaocheng Tian ,Author : 17 / October / 2023

3.2 Analysis of the "March 3rd of the Zhuang Nationality · Bagui Carnival"

Since 2018, The "March 3rd of the Zhuang Nationality · Bagui Carnival" activity held in Guangxi Zhuang Autonomous Region, Its core content has been steadily established as the five core sectors, Specifically, it includes: "March 3rd of the Zhuang Nationality · Bagui Zhuang Yun Strong" series of cultural activities, "March 3rd of the Zhuang Nationality · National sports dazzle" series of sports activities, "March 3rd of the Zhuang Nationality · Meet in Guangxi" series of tourism activities, " March 3rd of the Zhuang Nationality · e Online happy shopping " series of business activities, And the "March 3rd of the Zhuang Nationality · Harmony in Bagui" series of activities. This "five-in-one" expression accurately summarizes the five core activity areas of "March 3rd of the Zhuang Nationality · Bagui Carnival", aiming to further promote and deepen the excellent traditional culture of the Zhuang nationality and other ethnic groups by integrating the "March 3rd of the Zhuang Nationality" cultural resources of 14 cities in the region, so that it can occupy a more important role in people's life.

These five sections not only cover the wonderful display of the excellent traditional culture of various ethnic groups in Guangxi, but also integrate the competitive charm of traditional ethnic sports, the online and offline marketing strategies of famous and excellent special products, the extensive promotion of tourist attractions, and the profound connotation of ethnic unity and the family of the Chinese

nation. Together, they constitute the "March 3rd of the Zhuang Nationality" + "March 3rd of the Zhuang Nationality · Traditional ethnic culture display + economic construction + tourism promotion + ethnic sports + ethnic unity" this comprehensive and in-depth "March 3rd of the Zhuang Nationality · Bagui Carnival" activity framework, Successfully realized the organic integration of the traditional "March 3rd of the Zhuang Nationality" festival and the modern "Bagui Carnival" activities (Figure 69). The integrated characteristics of "March 3rd of the Zhuang Nationality · Bagui Carnival" are not only reflected in the "five-in-one" layout of its overall content structure, but also fully reflected in the comprehensiveness and integration of the content of each plate.



Figure 70 March 3rd of the Zhuang Nationality Five sections of Bagui Carnival
Source : Yaocheng Tian ,Author : 17/January/2024

3.3 Effectiveness analysis of "March 3rd of the Zhuang Nationality · Bagui Carnival"

First, remarkable results in political guidance have been achieved

After years of careful cultivation, "March 3rd of the Zhuang Nationality · Bagui Carnival" has developed into a grand event with far-reaching influence, which fully demonstrated the unique charm of national culture, effectively promoted the prosperity and development of local economy, and significantly promoted the process of national unity and progress. More importantly, in the process of communication, communication and integration, various ethnic groups have enhanced their mutual understanding and unity, and enhanced their recognition of the great motherland, the Chinese nation, the Chinese culture, the Communist Party of China and socialism with Chinese characteristics (Fang, 2022, P: 1-10).

The reason why "March 3rd of the Zhuang Nationality" can become a national cultural festival brand jointly enjoyed and created by all ethnic groups in Guangxi is closely related to the profound cultural symbols and strong cohesion contained in it,

and is the result of the unremitting efforts of the Party and government departments at all levels in Guangxi always adhering to the guidance of socialist core values. As "March 3rd of the Zhuang Nationality · BaGui carnival" national text brigade brand awareness, the enhancement of people of all nationalities culture confidence and patriotism at the same time, will also be the "construction of Guangxi, round Renaissance dream" great journey into a steady stream of power, powerful booster new era of socialism with Chinese characteristics of the construction of Guangxi grand blueprint into reality.

Second, the effect of tourism consumption

Under the overall layout planning of the government of Guangxi Zhuang Autonomous Region, "March 3rd of the Zhuang Nationality" has become a carnival festival for the people of the whole region, successfully built the cultural tourism brand of "March 3rd of the Zhuang Nationality, Bagui Carnival", and become a pearl of the traditional cultural brand of Guangxi. On April 27, 2021, General Secretary Xi brocade ping said at the Guangxi Museum of Nationalities that it is a good thing to carry forward the culture of March 3rd and promote the current tourism industry, and the tourism industry in Guangxi has a great future. "March 3rd of the Zhuang Nationality · Bagui Carnival" series of activities are rich and colorful, attracting a large number of tourists, promote the development of local tourism and cultural industry, and promote the development of local economy. For example, during the "March 3rd of the Zhuang Nationality" period in 2017, Guangxi received about 12.962,700 tourists, the total tourism consumption was about 8.363 billion yuan; in 2018 received 16,153,900 tourists, the total tourism consumption was 12.646 billion yuan; in 2019 received 19,120,800 tourists, the tourism consumption was 14.98 billion yuan, with year-on-year growth of 16.92% and 18.46%. In 2018, "March 3rd of the Zhuang Nationality" activities covered the vast minority rural areas, with 640 rural singing sites, and more than 300 cultural tourism activities were held in all over the region. The five-day holiday of the "March 3rd of the Zhuang Nationality" in 2018 alone has brought rich economic value to the ethnic minority villages in Guangxi. for example, Liuzhou rural folk festival activities: Sanjiang Fulu "Fireworks Festival", Rongshui Three Defense Song Festival, Luzhai "Pingshan Mountain Song" performance, etc., Attracted a large number of tourists, Revenue of nearly 3 billion yuan; More than 20 zhuang ethnic cultural activities, such as hammer dance, Tongqian dance, Huashan boxing, bamboo dance, A total of 1,183,100 tourists were received, Comprehensive consumption of tourism reached 594 million yuan; Wuzhou's "March 3rd of the Zhuang Nationality" series of activities are full of Lingnan flavor, In Shengpo Village, Cangwu County, The fireworks grab campaign attracted tens of thousands of onlookers, The scene is very spectacular; Sizhou Village, Fuwan Village, Farming Culture Park 3 folk special activities attracted 100,000 tourists; Qinzhou Fishermen's MIDI Music Festival attracted 70,000 visitors to watch the performance (Luo, 2019, P:80).

Third, the effectiveness of media communication

After an in-depth analysis of the communication effect of "March 3rd of the Zhuang Nationality · Bagui Carnival" on the financial media platform, it is found that the activity has successfully attracted a lot of attention. In 2018, the Beibu Gulf online website of Guangxi Radio and TELEVISION Station and the new media platforms of various frequencies opened the special topic of "March 3rd of the Zhuang

Nationality · Bagui Carnival", which reported the grand festival of Guangxi people from an all-round and multi-angle through audio and video, 3 d animation and light application H5 form. At present, the website and new media push 236 messages, with a total reading volume of 4.32 million times. Among them, the topic of "March 3rd of the Zhuang Nationality · 100 DJ" on Sina Weibo of Guangxi Radio and Television Station exceeded 1,841 million times, and the cumulative click of each wechat public account exceeded 1,035 million times. In November 2021, Guangxi's cultural and tourism image propaganda video "Meet the Heart of Guangxi" was read by 200 million people on Weibo. In 2023, Guangxi Radio and Television Station undertook the "Chaoyin · 2023 New Folk Song Challenge". By May 8 of that year, videos related to "New Folk Songs Challenge" and "Challenge New Folk Songs" were played on TikTok over 150 million times, and Sina topics were read more than 25 million times; "New Folk Song Challenge" and Facebook exceeded 3.5 million times.

Fourth, the effectiveness of brand building

"March 3rd of the Zhuang Nationality", a national cultural festival brand, can become a model of sharing and creating by all ethnic groups in Guangxi, mainly due to its rich cultural symbols and strong cohesion deeply rooted in the ethnic festivals, as well as the positive achievements of the party and government departments in Guangxi unswervingly guided by the socialist core values. Through the careful integration of the excellent traditional culture of various ethnic groups in Guangxi, including the core layer of Zhuang, Yao, Miao, Dong, Maonan and other ethnic cultures, a multi-level industrialization operation system has been gradually constructed. This system takes performing arts, cultural experience, the creation, production and sales of cultural products as the middle layer, and further extends to the peripheral layer of cultural tourism and related industries, thus greatly promoting the creative transformation and innovative development of national traditional culture.

Fifth, the effectiveness of the social memory

March 3rd of the Zhuang Nationality The successful shaping of the national festival culture brand is of great practical significance. This move not only promotes the effective protection and sustainable development of the excellent traditional culture of the Zhuang nationality, but also provides a broader platform for the promotion and inheritance of the excellent traditional culture of other ethnic minorities in Guangxi. As a concentrated display of the essence of folk custom and traditional culture, March 3rd of the Zhuang Nationality deeply carries the long historical deposits and rich traditional elements of the ethnic group, and is an indispensable cultural symbol. In addition, the festival has also become an effective way to build and strengthen public memory. Through the joint participation of various ethnic groups, they can gradually build a national emotional bond and social memory system based on mutual attraction, integration and identification when experiencing and sharing the profound cultural elements contained in the festival.

Part IV: Evaluation and discussion

It has been seven years since the "March 3rd of the Zhuang Nationality · Bagui Carnival" was held in 2017. Under the careful organization and planning of the People's Government of Guangxi Zhuang Autonomous Region, March 3rd of the Zhuang Nationality has presented a new look to the people of the country and even the world. March 3 has been given a new mission and cultural significance, and has become one of the shining images of the Zhuang people.

4.1 Evaluation

"March 3 rd" is a common cultural heritage of the Chinese nation. Under the careful planning and organization of the government of Guangxi Zhuang Autonomous Region, it has developed into a carnival for the people of Guangxi and even the whole country. This grand occasion deeply reflects the great importance and firm determination of China to the inheritance of national culture. Guangxi Zhuang brocade As an indispensable and important element of Zhuang culture, Guangxi Zhuang brocade combined with "March 3rd of the Zhuang Nationality", in order to promote the coexistence of ethnic cultures, highlight cultural confidence, strengthen cultural identity and promote extensive cultural exchanges.

(1)The bond of the national centripetal force

March 3rd of the Zhuang Nationality Cultural activities, their contents continue to be enriched and rich, especially reflected in the profound national charm of the song activities, these activities with diversified forms and rich and colorful content, make the song fair or song festival to some extent become the iconic title of March 3rd of the Zhuang Nationality. In addition, parties, commodity trade and other diversified activities have also been strengthened and promoted in this process. This fully demonstrates that March 3, as a vivid example of cultural integration and mutual learning between ethnic minorities and the Han nationality, is a precious cultural wealth to build the sense of community of the Chinese nation. Therefore, we should highly cherish and make full use of March 3rd of the Zhuang Nationality cultural activities, continue to promote the high quality, committed to the creative transformation and innovative development of the culture, so as to continuously consolidate the sense of community of the Chinese nation, gather the majestic power of the people of all ethnic groups in China, and jointly build the Chinese dream of the great rejuvenation of the Chinese nation.

(2)The carrier of folk culture inheritance and display

The traditional festival of "March 3rd of the Zhuang Nationality" not only carries the traditional customs of making five-color glutinous rice, dyeing red eggs, dragon and lion performance, and stepping on the hall, but also generates the folk customs such as singing and singing in the development of The Times, as well as new forms and carriers such as "March 3rd of the Zhuang Nationality" ethnic costume display and Luoyue Cultural Tourism Festival. These innovations not only retain the essence of traditional culture, but also skillfully integrate fashion elements, making "March 3rd of the Zhuang Nationality" glow with new vitality. In Guangxi region, the cultural revival of "March 3rd of the Zhuang Nationality" has become a trend that cannot be ignored. The symbolic expressions of the festival, such as patterns, statues, stage props, frequently appear in public Spaces and major occasions. They not only highlight strong ethnic customs and profound historical deposits, but also gradually

become outstanding representatives of ethnic cultural symbols in Guangxi region. Through this symbolic expression of national culture, the people of Guangxi have not only realized the regeneration and self-identification of national culture, but also successfully built a cultural ecological space full of poetry and harmony in the world cultural map. This process not only promotes the inheritance and development of national culture, but also brings real benefits of cultural industry, and injects new impetus into the economic and social development of Guangxi.

(3) Platform for promoting and promoting Zhuang culture

From the press conference of "March 3rd of the Zhuang Nationality · Bagui Carnival" on April 11, 2023 to May 22 of the same year, the total amount of information about Guangxi "March 3rd of the Zhuang Nationality" on the Internet platform has accumulated to more than 290,000. In the collected "March 3rd of the Zhuang Nationality" information collected, the top ten keywords mentioned the most frequently are: March 3, Guangxi, Zhuang, Carnival, holiday, ethnic culture, Nanning, cultural tourism, 21st, and folk songs. The topic has received a staggering 1.05 billion exposures (Figure 70).



Figure 71 Hot topic of March 3rd of the Zhuang Nationality in 2023

Source: <https://baijiahao.baidu.com/s/17/January/2024>

By actively protecting and inheriting the unique culture of "March 3rd of the Zhuang Nationality", Guangxi has not only committed to promoting and carrying forward the Zhuang culture, but also strengthened international cultural exchanges and cooperation. The move is to give full play to the positive role of "March 3rd of the Zhuang Nationality" traditional activities in cultural inheritance and social cohesion. This will not only contribute to the protection and inheritance of Guangxi's intangible cultural heritage, but also promote the prosperity and development of local culture, and build a bridge for people around the world to understand and appreciate Guangxi culture.

4.2 Discussion

The successful creative transformation and innovative development of "March 3rd of the Zhuang Nationality · Bagui Carnival" in Guangxi also help how the tradition of this new invention become the collective social memory of contemporary Zhuang people in the context of modern society, which is also the problem that must be solved when "March 3rd of the Zhuang Nationality · Bagui Carnival" becomes the new tradition of Zhuang people in the future.

There is also some discussion about "March 3rd of the Zhuang Nationality", As Liang Tingyu pointed out in the Introduction to Zhuang Culture that the third day of the third lunar month is the main date of Tomb Sweeping Festival, It is also a grand song festival, On the day to commemorate the birth of Shennong, It is also the temple festival of Luocheng Zhuang people in Guangxi (Liang, 2000, P:475-476); Lu Xiaoqin's "What is" Song Wei "—— The concept of" Song Wei "and the folk expression in the vision of literati scholars" points out that, "The folk singing activities of the Zhuang nationality characterized by 'song Wei' is a tradition of flowing around the theme of 'party song', Its change is the norm " (Lu, 2005, P:72-81); Li Fuqiang's Praise of Spring: March 3rd of the Zhuang Nationality Song Festival, From the long history, unique customs, attractive food, magical legend, the inheritance of the five aspects of the "March 3rd of the Zhuang Nationality" this festival was introduced in detail, The "March 3rd of the Zhuang Nationality" has the customs of driving song fair, throwing hydrangea, touching colored eggs, worshiping ancestors and sweeping tombs, climbing mountains, fighting chickens, grabbing fireworks and steaming five-color glutinous rice (Li, 2018, P:1-141); In terms of the festival flow of the "March 3rd of the Zhuang Nationality", Researchers have also seen the progression of "March 3rd of the Zhuang Nationality" to the contemporary, Its connotation, the main body and the festival procedure have changed a lot. Xu Xiaoming's "From Ethnic Identification to Cultural Sharing —— The Changes of March 3rd of the Zhuang Nationality since the 19 80 s" combs the change process of March 3rd of the Zhuang Nationality since the 19 80s from the aspects of festival name and connotation, time and space, the main body of festival organization, festival procedures and content. It is pointed out that March 3rd of the Zhuang Nationality has changed from a traditional festival featuring sacrifice and tomb sweeping to a festival featuring singing and folk activities, and its organization has also developed from folk organization to ethnic festival activities led by government departments and jointly promoted by local elites, scholars and media (Xu, 2018, P: 8-12).

As described again, Some are discussed from a developmental perspective, Ren Xubin's "Discussion on" March 3rd of the Zhuang Nationality "telling the Story of Guangxi" (2017), "Thoughts on" March 3rd of the Zhuang Nationality "as a Modern International Festival" (2018), and "Research on" March 3rd of the Zhuang Nationality "Festival Innovation" (2020) focus on exploring "March" 3rd of the Zhuang Nationality " of the international development path, Building an international festival system; Sun Qiaochu pointed out in his article "National Inheritance" of Intangible Cultural Heritage from the Guangxi Zhuang Nationality ", "National inheritance" is the key to the protection of intangible cultural heritage, The protection of intangible cultural heritage should be strengthened from the three aspects of cultivating non-genetic inheritors, strengthening school education and actively promoting the society (Sun, 2018, P:34-39); Pan Lu's master's thesis "Research on the Modern Transformation of The Ceremony Communication of The Zhuang Song Wei" points out that the subject of the inheritance and dissemination of folk culture in ethnic minority areas should return to the local people, Attention should be paid to the role of diversified media communication in broadening its cultural circle layer, Ritual sharing and identity in local cultural circles should be strengthened (Pan, 2018, P:1-64); Yan Yi's "Recognition and Inheritance:" March 3rd of the Zhuang Nationality "Festival Cultural Interaction in Universities", The "March 3rd of the Zhuang Nationality" festival interactive activities in universities should be developed from four aspects: building campus interactive activity places, attaching importance to national culture classroom education, optimizing the communication mode of brand activities, and strengthening the awareness of Chinese cultural identity (Yan, 2020, P:194-196); March 3rd of the Zhuang Nationality This national festival brand, As a cultural brand jointly created and shared by the people of all ethnic groups in Guangxi, And the prominent symbols and symbols of Guangxi Zhuang culture, Its formation and development have gone through a long course of evolution. In this process, March 3rd of the Zhuang Nationality continues to enrich and sublimate in content and form with the pulse of The Times, realizing the leap from single to multiple, and building a cultural form of cultural activities, tourism and economy that highly integrates the boundaries of region, nationality, language and space-time and space. At the same time, March 3rd of the Zhuang Nationality needs to be clear that any operation mode, eager for quick success and quick benefit, divorced from the reality, is difficult to achieve the expected goal, and may even cause the reverse effect.

Part V:propose

First, based on the construction of the common spiritual home of the Chinese nation and the cornerstone of cultivating the cultural identity of the Chinese nation, we should unswervingly follow the socialist core values and guide all ethnic groups to realize the creative transformation and innovative development of the national traditional culture in the process of inheriting and protecting the excellent traditional culture. In addition, the core concepts of rural revitalization, ecological protection and rural customs construction should be integrated to further enrich the cultural connotation of "March 3rd of the Zhuang Nationality" and "Guangxi Zhuang brocade", so as to create a collective spirit widely recognized and deeply rooted in the people's hearts.

Second, organize experts and scholars to go deep into the fields to conduct basic data research in sociology, anthropology, art and other fields on "March 3rd of the Zhuang Nationality", "Guangxi Zhuang brocade" and other intangible cultural heritages in Guangxi, aiming to build a solid theoretical foundation and promote the effective inheritance and development of Zhuang culture. At the same time, we will be committed to establishing a set of standardized and systematic "March 3rd of the Zhuang Nationality" and "Guangxi Zhuang brocade" cultural ritual process, to ensure that the "March 3rd of the Zhuang Nationality · Bagui Carnival" cultural activities can maintain the original flavor of all kinds of intangible cultural heritage, and enhance the sense of ritual and cultural connotation of Guangxi Zhuang brocade in the activities.

Third, from many disciplines, including sociology, psychology, marketing and communication, in-depth analysis and extraction of the representative, typical and profound patterns and symbols, such as gorgeous Guangxi Zhuang brocade, melodious folk songs, ancient bronze drums, symbols of love and mysterious huashan murals. These elements are carefully planned and designed to merge into an easily recognized and easily disseminated "March 3rd of the Zhuang Nationality · Bagui Carnival" event badge. Through the continuous publicity and repeated exposure of various media platforms, we aim to make this badge leave a deep impression in the public mind and form a fixed cognitive impression. In addition, a series of exquisite "March 3rd of the Zhuang Nationality" cultural brochures, covering the origin of "March 3rd of the Zhuang Nationality", representative folk songs, ethnic stories, rich folk culture and easy transliteration of Zhuang language. These manuals will be widely distributed in the areas of the Guangxi Zhuang Autonomous Region, so as to let more outsiders know and understand the "March 3rd of the Zhuang Nationality" and Guangxi Zhuang brocade culture in Guangxi. At the same time, we call on all Guangxi tourists to undertake the responsibility and mission of promoting Guangxi, and also encourage all tourists to actively spread and share their beautiful experiences and feelings through various channels and platforms, and contribute to the promotion of culture and tourism resources in Guangxi.

Fourth, the original ecological folk songs are deeply integrated with Guangxi Zhuang brocade, Zhuang Opera, Guangxi Opera, color tone, literary field and other ethnic literature and art forms, and a new form of ethnic minority culture and art with distinctive Guangxi characteristics can be created through refining, sublimation and integration. At the same time, we pay attention to cultivating young creators of minority culture and art, so that they will become an important force to promote the inheritance and development of minority culture and art. We have increased our support for the original music, dances and original crafts of ethnic minorities, and encouraged the creation of more works with ethnic characteristics and artistic value. In addition, we are also committed to combining "March 3rd of the Zhuang Nationality" traditional festivals such as Singing Fair and Singing Po with modern music, pop elements and fashion crafts, so as to attract more groups at different levels to participate in it and experience the open, inclusive and colorful cultural charm of "March 3rd of the Zhuang Nationality" together.

Fifth, it will commit to showing the cultural connotation of "March 3rd of the Zhuang Nationality" in a concrete form. By planning and enriching cultural activities in various places, it will carefully design a series of cultural projects that can attract

the active participation of the audience and produce profound cultural identity. At the same time, we will actively develop cultural and creative products with distinctive local characteristics, such as Zhuang brocade, Zhuang embroidery, bronze drum, etc. These products can not only stimulate consumption, but also become a medium for tourists to bring "March 3rd of the Zhuang Nationality" cultural experience back to their hometown, so as to achieve wider cultural communication and communication across the country.

Using the advantages of the platform and mechanism, with the help of "March 3rd of the Zhuang Nationality", "to" China-asean "and" area "as the theme of foreign cultural activities, set up" asean SAN SAN " cultural center, speak good Chinese story, good Chinese voice, credible, lovely, respectable image of China, promote Guangxi culture and the Chinese culture to the world, promote cultural soft power and influence.

Sixth, we will continue to strengthen the construction of platforms for foreign cultural exchanges. In view of the close connection between Guangxi and ASEAN region in land and sea, its geographical location is at the intersection and key region of the "Belt and Road" Maritime Silk Road. It is the core gateway of cooperation and exchange between China and ASEAN, and the host of the China-ASEAN Expo. The two sides have a profound cultural common foundation. Therefore, "March 3rd of the Zhuang Nationality" festival activities have shown distinctive international characteristics. Make full use of the advantages of the existing platforms and mechanisms, relying on the cultural carrier of "March 3rd of the Zhuang Nationality", and carefully plan and hold foreign cultural exchange activities with the theme of "China-ASEAN" and "Belt and Road". During the event, we will set up a special "ASEAN March 3 rd" cultural center, aiming to vividly tell Chinese stories, spread China's voice, and fully present a credible, lovely and respectable image of China. The move is designed to further promote the internationalization of Guangxi culture and even Chinese culture, and enhance China's cultural soft power and international influence.

Summary

In the first part, as an important part of the traditional culture of the Chinese nation, its cultural genes have been continuously inherited and evolved in the long history. It has gradually expanded from the Shangsi Festival of the Han nationality to the March 3rd celebration of ethnic minorities, and finally become the unique traditional March 3rd festival of the Zhuang nationality. This festival has been widely spread among the people. Since 2016, the People's Government of Guangxi Zhuang Autonomous Region has actively created the "March 3rd of the Zhuang Nationality : Bagui Carnival" activity, aiming to re-regulate and enrich the celebration ceremony of "March 3 rd", and inject new connotation of The Times and symbolic significance into it. Through the innovative measures of nationalization, modernization and symbol, not only the content of the activity is enriched, but also the festival has become the most influential event of ethnic, cultural and custom identification in Guangxi Zhuang region in the new era. This has further promoted the exchanges and integration among various ethnic groups, strengthened the sense of community of the Chinese nation, with a high sense of responsibility and mission, committed to writing a new chapter of Chinese modernization in Guangxi, and

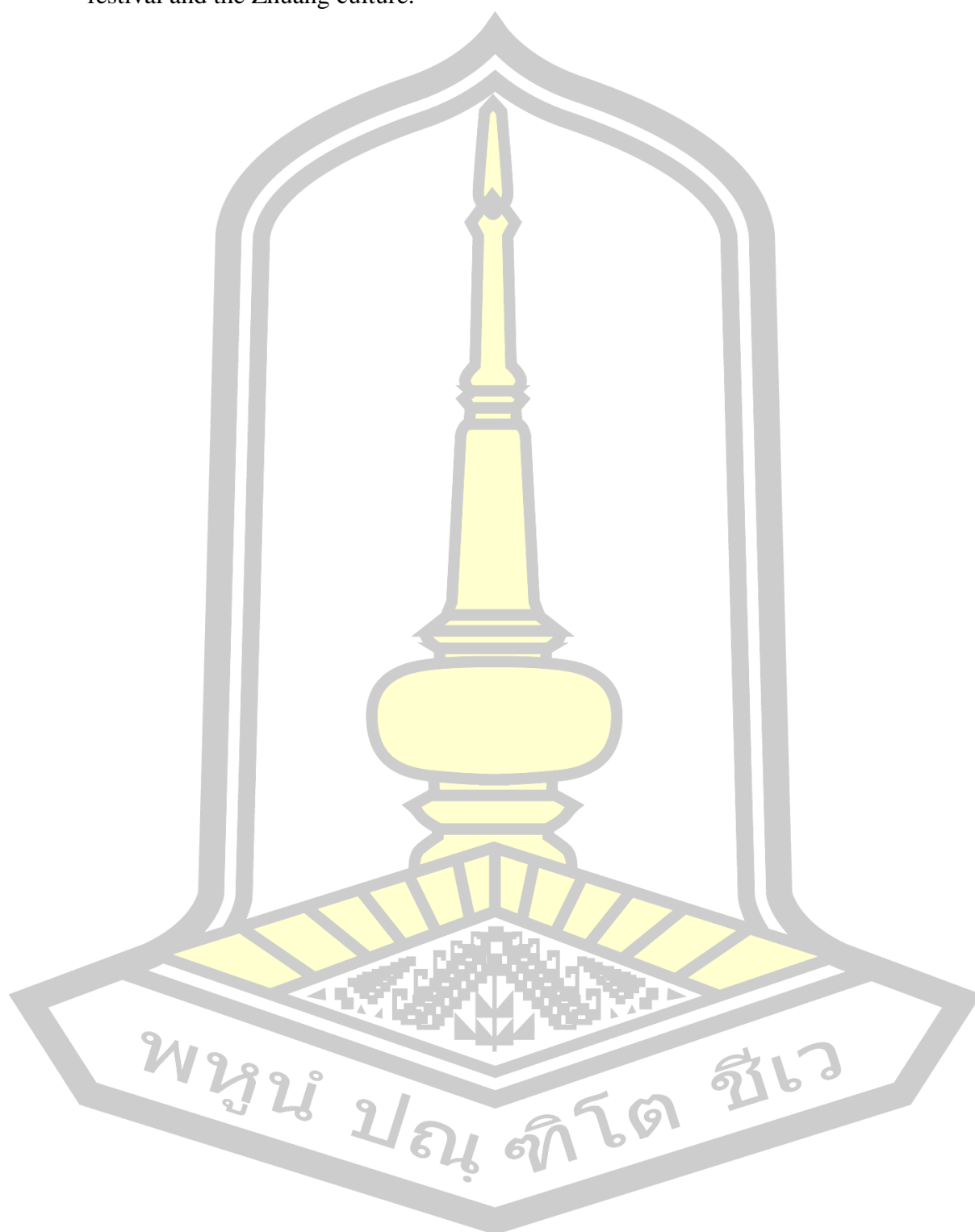
contributed Guangxi's strength and luster to the Chinese dream of the great rejuvenation of the Chinese nation.

In the second part, An in-depth analysis of the business nature of the "March 3rd of the Zhuang Nationality · Bagui Carnival", Combining the social memory concept explored in this paper with the "traditional invention" theory, It is not difficult to find that the government of Guangxi Zhuang Autonomous Region is using the March 3rd of the Zhuang Nationality festival, Actively reconstruct the social memory framework shared by the Zhuang people and all ethnic groups under the background of the new era. In this activity, the government skillfully integrated traditional cultural elements with modern life concepts, realizing the seamless connection between traditional culture and modern society, and creating a harmonious symbiotic atmosphere of "interlinked". To be specific, traditional culture and art are deeply embedded in people's daily life, labor and production, secular activities and cultural celebrations, which has a strong resonance with the modern lifestyle, and further strengthens the sense of identity and belonging of national culture. This paper analyzes how "March 3rd of the Zhuang Nationality" has realized a magnificent transformation from traditional to modern under the multiple joint force of government leadership, enterprise support, extensive social participation and the effective operation of the market. The traditional "March 3rd of the Zhuang Nationality" festival, on the stage of the new era, with a new identity, image and content to appear again, not only retains its profound historical heritage and cultural tradition, but also coruscated with unprecedented vitality and vitality. This process has not only successfully shaped "March 3rd of the Zhuang Nationality" as the most iconic cultural symbol in Guangxi in the new era, but also demonstrated the important role of the government, enterprises, society and the market in cultural inheritance and innovation.

In the third part, after an in-depth analysis of the activity content, plate division and achievements of "March 3rd of the Zhuang Nationality · Bagui Carnival", "March 3rd of the Zhuang Nationality" has not been limited to the cultural celebration of a certain nation, but evolved into a cultural industry brand with the participation and creation of all nationalities. This brand has been further sublimated and become an important symbol and image with distinctive characteristics and representing Chinese culture. In the construction of its activity framework, we have adopted the scientific and reasonable "five-in-one" mode to realize the organic integration of each plate. To be specific, through the promotion of tourism consumption and media communication, the "March 3rd of the Zhuang Nationality" activity not only promotes the cultural exchange and sharing of various ethnic groups, but also greatly attracts the attention of tourists, injecting strong impetus into the development of local tourism and cultural industry. This process not only drives the prosperity of the local economy, but also gives new vitality to the inheritance of modern folk festivals, keeping it fresh and dynamic. Therefore, "March 3rd of the Zhuang Nationality" has become an important starting point for To promote the integrated development of rural revitalization and cultural tourism industry in Guangxi, and its value and significance cannot be ignored.

In the fourth part, based on the in-depth analysis and evaluation of experts, scholars and government officials, the historical development trajectory of the "March 3rd of the Zhuang Nationality · Bagui Carnival" activities and its extensive impact are systematically evaluated. On this basis, some forward-looking and feasible strategies

and suggestions are put forward for the inheritance and development of the traditional festival and the Zhuang culture.



CHAPTER VI

Conclusion discussion and suggestions

Part I : Conclusion

The topic of this paper is: "Guangxi Zhuang brocade: social memory and traditional invention in the context of reform and open to the outside world in China".
Study method: This study uses the qualitative research method.

Information collection methods: Two kinds of information collection methods were used in this study: field survey and literature study. In the process of research, after consulting the relevant literature of Zhuang brocade, the paper asked questions to the field investigation and interview work, and collected a large number of first-hand data to carry out the follow-up research work.

The purpose of this study is to:

1. Study the historical and artistic value of Guangxi Zhuang brocade.
2. to study and analyze the "social memory" of Guangxi Zhuang brocade before reform and open to the outside world and after reform and open to the outside world.
3. Study and analyze the "traditional invention" of Guangxi Zhuang brocade after reform and open to the outside world.
4. Explore the social memory of Guangxi Zhuang brocade and traditional inventions through folk activities under the background of reform and open to the outside world in China.

The research purpose of this paper is as follows:

Study the historical and artistic value of Zhuang brocade in Guangxi

This chapter aims to elaborate on the natural and cultural environment of Guangxi Zhuang brocade's growth, and deeply combine with the long historical background of zhuang textile industry, and conduct rigorous textual research on the development process of Guangxi Zhuang brocade. Through the study and analysis of brocade unearthed in the Han Dynasty, it is confirmed that brocade was imported into Guangxi as foreign commodities during the Han Dynasty. Since the rise of Guangxi brocade in the Song and Yuan dynasties, through the evolution of soil brocade in the Ming and Qing Dynasties, until the Republic of China and the contemporary Zhuang brocade, this series of processes basically constitute the context of Guangxi Zhuang brocade development.

Guangxi Zhuang brocade The evolution is closely linked to the social and cultural environment of the Zhuang people, and their artistic characteristics are displayed through their unique composition, bright colors and rich patterns. These patterns are not only deeply rooted in the totem worship and religious beliefs of the Zhuang, but also closely linked with the customs and habits of the Zhuang, which constitute the profound heritage of the Zhuang brocade culture. In the collective memory and social memory of the Zhuang people, Guangxi Zhuang brocade carries important historical and cultural values and plays an irreplaceable role.

1.The "social memory" of Guangxi Zhuang brocade before and after reform and open to the outside world was studied and analyzed.

Guangxi Zhuang brocade As a treasure of the Zhuang nationality culture, it carries the rich social memory. In the course of its development, it not only absorbed the exquisite skills and artistic inspiration of Tang style and Liao style satin brocade in the Central Plains, but also evolved into the modern Guangxi Zhuang brocade under the influence of chieftain system and zhuang culture in the Ming and Qing dynasties. This cultural treasure deeply integrates the original totem worship and polytheistic belief elements, and is closely related to the totem belief system of the Zhuang people. It becomes an important link connecting Guangxi Zhuang brocade and the spiritual world of the Zhuang people, and plays an indispensable role of social memory symbol in all kinds of totems and belief ceremonies.

In the important life rites of the Zhuang society, Guangxi Zhuang brocade plays an important role. It is not only a precious memory symbol in the ceremony, such as birth ceremony, coming of age ceremony, wedding and funeral, but also a warm symbol of family affection, the symbol of love, the symbol of ability and the symbol of peace of home. In addition, in daily life, Guangxi Zhuang brocade also serves as a medium for emotional transmission and social interaction between men and women of the Zhuang nationality, inspiring Zhuang women to pursue a happier life.

However, with the rapid development of market economy and the widespread popularity of cheap textiles, Guangxi Zhuang brocade gradually faded from the stage of daily life of the Zhuang people and became a symbol of identity and belonging, which was deeply imprinted in the collective memory of the Zhuang people. At present, the inheritance of Zhuang brocade skills is mainly realized through the way of oral teaching and mentoring and the promotion of intangible cultural heritage protection projects. At the same time, with the help of modern training means, more people have the opportunity to experience and feel the unique charm of Zhuang brocade skills.

To sum up, Guangxi Zhuang brocade not only carries the profound historical memory and cultural connotation, but also seeks a new development path in the process of inheritance and innovation. Therefore, in the process of promoting its inheritance and development, we should attach great importance to the principle of both protection and innovation, so as to ensure the sustainable inheritance and development of Guangxi Zhuang brocade cultural heritage.

2.Study and analyze the "traditional invention" of Guangxi Zhuang brocade after reform and open to the outside world.

In the process of Guangxi Zhuang brocade as the iconic symbol of Zhuang culture, the government plays an important role. First, the government, through a series of measures such as the protection of intangible cultural heritage, has given Zhuang Brocade a new identity and firmly established its status as a representative of Zhuang culture. In addition, the government actively promotes the deep integration of Guangxi Zhuang brocade with diversified art forms, such as Guangxi opera, animation art, music creation and opera performance, and further shapes Zhuang brocade as a concrete symbol of the vision of the pursuit of happiness and a better life. This series of measures has not only significantly enhanced the cultural

connotation and value of Guangxi Zhuang brocade, but also greatly promoted its wide dissemination, make it deeply rooted in the hearts of people's hearts, and become a cultural treasure cherished by all sectors of society.

Second, as an outstanding model of Zhuang culture, the giant Zhuang brocade has become an important symbol of Guangxi region and Zhuang culture, and occupies a pivotal position in the evolution of Zhuang brocade skills. Through its appearance in major events at the national and autonomous region level, it has successfully promoted Guangxi Zhuang brocade from local folk to a broad stage of international vision, and opened up unprecedented application situation and display space. This move not only highlights the innovative achievements of zhuang brocade production technology and the artistic leap of pattern design, but also builds a solid foundation for the wide spread and far-reaching inheritance of Zhuang culture. The giant zhuang brocade is not only a key link in the practice of "traditional invention", but also an important medium for the Zhuang culture to show its unique style and charm to the world.

Third, Zhuang brocade making technology has evolved through many stages, and its traditional loom can be divided into four categories: brocadexi brocade loom, bamboo cage machine, Huanjiang Zhuang brocade loom and dragon boat brocade loom. In order to further improve the production efficiency and broaden the width of zhuang brocade fabric, the introduction of improved seed brocade machine and innovative silk weaving machine not only promotes the Guangxi Zhuang brocade weaving technology to achieve modern mechanization transformation, the production efficiency is significantly improved, and cleverly retains the unique traditional charm of Zhuang brocade. It also promotes Zhuang brocade products to more fit the market demand, meet the diversified expectations of consumers, and lays a solid foundation for the inheritance and prosperity of Zhuang brocade culture.

Fourth, patterns and patterns, as the core power of zhuang brocade inheritance for thousands of years, in the process of "traditional invention", we must keep in touch with the past, not fabricated out of nothing. Guangxi Zhuang brocade The pattern design can be divided into two main categories: pattern type and pattern type, which can be further refined into traditional type and "traditional invention" type. Traditional patterns and patterns are deeply rooted in the fertile soil of Zhuang culture and national life, while the "traditional invention" patterns are mostly carefully created by modern designers or professionals in the field of fine arts. In the process of "traditional invention", the pattern design skillfully integrates the essence of Zhuang folk art, such as the simplicity of the bronze drum pattern, the magnificence of the Huashan rock paintings and the vivid brocadexi peasant paintings, and integrates these elements into the composition of Guangxi Zhuang brocade, so as to show the unique charm and extraordinary charm of Guangxi Zhuang brocade and Zhuang culture.

Finally, Guangxi Zhuang brocade In the practice of "traditional invention", the government plays a core leading role. By spreading the legend of a Zhuang Brocade, and the implementation of intangible cultural heritage protection strategies, the government successfully established the important position of Guangxi Zhuang brocade as a symbolic symbol of Zhuang culture. In addition, the following suggestions are put forward to the government: In order to realize the living inheritance of Guangxi Zhuang brocade, emphasis should be placed on building the

use ceremony of Guangxi Zhuang brocade in folk activities in the new era, and shaping its living space in the city. The implementation of these key measures will be conducive to promoting the inheritance and development process of Guangxi Zhuang brocade culture.

3. Explore the social memory of Guangxi Zhuang brocade and traditional inventions through folk activities under the background of reform and open to the outside world in China.

This chapter takes "March 3rd" this folk activity as the core topic to discuss. As an important part of the traditional culture of the Chinese nation, "March 3rd" has been inherited and evolved in the long history. From the Shangsi Festival of the Han nationality —— "March 3rd" ethnic minority —— Zhuang traditional "March 3rd" —— "March 3rd of the Zhuang Nationality", in this process, "March 3rd" maintained an important position as a folk festival activities.

Since 2016, the People's Government of Guangxi Zhuang Autonomous Region has taken active actions to build the "March 3rd of the Zhuang Nationality · Bagui Carnival" activity. This move not only reformulated the ritual specification of "March 3rd of the Zhuang Nationality", but also endowed it with a new era connotation and symbolic significance. Through the rich and diverse contents of activities, Guangxi Zhuang Autonomous Region, on the basis of tourism consumption, has carried out in-depth innovation and transformation of the traditional "March 3rd" festival, and realized the comprehensive upgrade of nationalization, modernization and symbolization. This initiative has greatly enhanced the sense of nationality, cultural identity and custom identity of Guangxi Zhuang, making "March 3rd of the Zhuang Nationality" the most influential carnival celebration of Guangxi Zhuang in the new era.

Under the guidance of the government of Guangxi Zhuang Autonomous Region, traditional culture and modern life have been deeply integrated, and the traditional festival "March 3rd of the Zhuang Nationality" has been successfully reshaped as a social memory shared by the Zhuang people and all ethnic groups in Guangxi in the new era. Through the coordinated participation of the government, enterprises, society and the market, the traditional "March 3rd" festival in Guangxi has stepped on the stage of the new era with a new identity, image and content, and has become the most representative and dynamic cultural symbol of Guangxi. "March 3rd of the Zhuang Nationality · Bagui Carnival" has carefully constructed a comprehensive and scientific "five-in-one" activity framework, attracted the attention of many tourists, significantly promoted the prosperity and development of local tourism and cultural industry, and become a key force to promote the development of rural revitalization and cultural tourism industry in Guangxi. With the joint participation and creation of all ethnic groups, "March 3rd of the Zhuang Nationality" has gradually grown into a unique Chinese cultural symbol and image.

Part II: Discussion

This research topic is "Guangxi Zhuang brocade: social memory and traditional invention in the background of reform and open to the outside world in China", with Guangxi Zhuang brocade as the research text and social memory and traditional invention as the research concepts. During the whole process of reform and open to the outside world, social memory was analyzed with traditional invention

First of all, in the existing historical research papers on Zhuang brocade, the researchers mostly focus on historical development and social function. Research on the history of brocade: Zhuang brocade, as a folk art formed in the long-term production practice of the Zhuang people, has a profound historical background. However, there are different academic opinions about the origin of Zhuang brocade. Such as a brief history of the Zhuang brocade, QinGuoSheng co-author "Zhuang" and Zheng Chaoxiong "Zhuang aesthetic consciousness source", Wu Weifeng in the history of the textile industry and the rise and fall of Guangxi Zhuang brocade, etc., analyzes the origin and development of Zhuang brocade, by combining the historical data and on-the-spot investigation, shows the Zhuang brocade history organized and persuasive. Although researchers gradually focus on the historical level of Zhuang brocade, there is still a lack of in-depth research on the social memory field of Zhuang brocade. However, few researchers have studied Guangxi Zhuang brocade from the perspective of social memory and traditional inventions. The collaboration with traditional invention provides a more scientific analysis of the history of folk art.

Second, about the brocade pattern study: road Joan Zhuang brocade grain study, Xu Xin, Lv Jie, Xiaoming Yang from the artistic characteristics to the causes of —Guangxi Zhuang brocade pattern interpretation, Zhang Brocade Miao the Zhuang brocade pattern national cultural connotation of Wu Hui Min preliminary Zhuang brocade geometric pattern origin, is based on the pattern of historical research or art analysis, rarely use interdisciplinary system to study the Guangxi Zhuang brocade pattern.

Third, about the brocade process research literature are: Xu "Zhuang traditional textile technology and its culture research, Wei-feng Wu of the brocade technology of Guangxi Zhuang, Wei-feng Wu, Cai," Zhuang brocade ", Wu Entertainment, Wei-feng Wu of the Zhuang traditional dyeing materials and Zhuang brocade dyeing technology and Tan Liping Guangxi Zhuang brocade brocade technology research. These studies explored the Zhuang brocade technique from the field or literature, but failed to pay attention to the significance of the change of the Zhuang brocade technique to this traditional craft. Therefore, the "traditional invention" concept used in this paper is a completely new attempt. After many field investigations, interviews, and took a large number of brocade machine and pattern photos. At the same time, from the study of Zhuang Brocade, I interviewed national intangible cultural heritage inheritors, national arts and crafts masters, brocade workers, etc., and obtained a large number of first-hand information, including some creative ideas of giant Zhuang brocade and some personal sensitive information, such as salary income, personal memories and so on. All of this information sets the foundation for the subsequent analysis.

Finally, the research on brocade culture and art include: Yushi's Zhuang Brocade Culture, Ye Hongguang, Li Bin's Study on Brocade Weaving: Research on

Tujia Brocade Culture; Wang Yiping and Mo Wanyu's Guangxi Zhuang brocade and its Cultural Value and Functional Changes —— Take Xincheng Zhuang Brocade as an example; Ma Hong's Aesthetic Art and Inheritance of Zhuang Brocade. For a long time, the cultural value of Zhuang brocade has been deeply explored. Zhuang brocade is an important part of Zhuang culture. It is one of the most important representative symbols of Zhuang culture. It is also an important carrier reflecting the customs, religious beliefs and aesthetic concepts of the Zhuang people, with rich cultural connotation.

Previous research on literature, historical data and papers is undoubtedly the basis of Zhuang brocade research and innovation. This is the relationship of the same origin, with very high reference values. Zhuang brocade Kou inherits the rich values, artistic values and social memory contained in the legend and patterns, reflecting the wisdom and talent of the general public. They are an important basis for the research.

The research presented in this paper is also based on our predecessors, Combining the framework of the National reform and open to the outside world, Under the background of national policy —— casting the sense of community of the Chinese nation, To protect and inherit intangible intangible cultural heritage, To construct the social memory national cultural identity, To exert the purpose and cultural power of the traditional invention, Optimize the material life and spiritual pursuit of the people of all ethnic groups in Guangxi, To forge a new chapter of socialist modernization with Chinese characteristics in the new era, Work together to create a brilliant future shared by all mankind, Constantly moving towards a new realm of comprehensive and balanced development of human society. Therefore, the research results of this paper have extensive theoretical basis and important practical significance.

Part III: Recommendation

3.1 Academic advice

First, as an important intangible intangible cultural heritage, Zhuang brocade art has shown high academic research value by virtue of its more than one thousand years of historical accumulation, profound cultural connotation and unique artistic characteristics. So far, many scholars have conducted in-depth discussions on the historical origin, production technology, cultural and artistic value, cultural and artistic value, intangible cultural heritage protection strategy and industrialization development of Zhuang brocade, and have achieved fruitful academic achievements. However, it cannot be ignored that Guangxi Zhuang brocade is currently facing severe challenges and crises in its living inheritance. In view of this, it is still of great historical significance and broad space to further broaden and deepen the research perspective and breadth of Guangxi Zhuang brocade based on the historical background of reform and open to the outside world in China. This not only helps us to have a more comprehensive and deep understanding of the cultural connotation and unique value of this Zhuang national treasure, but also provides an important reference for exploring its inheritance and development path under the background of the new era.

Second, the main goal of this paper is to deeply analyze the "social memory" and "traditional invention" carried by Guangxi Zhuang brocade in the macro background of reform and open to the outside world in China, so as to introduce a new perspective for the research in this field. In view of the fact that many Chinese

folk art forms are facing similar challenges and difficulties with Guangxi Zhuang brocade, the research model of this paper is not only applicable to Guangxi Zhuang brocade, but also provides a useful reference for the study of other intangible cultural heritage of folk skills with similar characteristics. It is expected that this research will stimulate future academic exploration, both in the expansion of research perspectives and in the innovation of research methods.

3.2 Social Suggestions

From the perspective of relevant government departments, based on the development data from field survey, this paper covers anthropology, sociology and art, and concludes that this research results can provide valuable reference for the government to plan the development strategy, promotion, policy support and specific measures of Zhuang brocade. For the people and the Zhuang ethnic groups in Guangxi, Guangxi Zhuang brocade is not only a material cultural heritage, but also a symbol of the profound Zhuang cultural spirit. Therefore, with the help of the specific case of "March 3rd of the Zhuang Nationality · Bagui Carnival", this paper deeply discusses how Guangxi Zhuang brocade can reconstruct the innovative way of Guangxi Zhuang brocade ceremony through "social memory" in the process of the new era and gain new vitality. At the same time, combining with the trend of tourism consumption, the paper will explore the possibility of opening up a broader space for the Guangxi Zhuang brocade market, aiming to attract more tourists to pay attention to and buy zhuang brocade products, so as to create more considerable economic benefits for brocade artists. At the same time, this paper also aims to contribute to the intangible cultural heritage protection and inheritance of Guangxi Zhuang brocade, through the combination of academic research and practical exploration, to strengthen the sense of community of the Chinese nation.

3.3 Suggestions on intangible Cultural Heritage Protection

First, with the government as the leading, combined with the actual needs of urban development and the market, to build folk rituals and consumption driving force matching the background of The Times, aiming to promote the prosperity and development of Guangxi Zhuang brocade culture. Second, actively promote the publicity and experience of Zhuang brocade skills, through opening special training courses, widely attract talents with strong interest and enthusiasm for Zhuang brocade art, and provide them with systematic learning and improvement opportunities. Third, the government set up a special fund for the research and development of new Zhuang brocade loom, to attract professional textile machinery designers in the form of bidding, to improve the traditional manual brocade machine, while maintaining the traditional skills of Zhuang brocade, reduce the dependence of Zhuang brocade production on human resources, and promote the market-oriented development of Zhuang brocade. Fourth, strengthen the sense of ritual of Guangxi Zhuang brocade intangible cultural heritage activities, skillfully integrate modern urban cultural elements, create a new display platform and folk custom connotation for Guangxi Zhuang brocade, and coruscate its new vitality. Fifth, increase the investment in the protection of Guangxi Zhuang brocade intangible cultural heritage research, through cross-border cooperation and joint ways, broaden the protection horizon, improve the level of protection, and promote the Guangxi Zhuang brocade intangible cultural heritage project to the height of world-class intangible cultural heritage protection.

Since both Guangxi Zhuang brocade and March 3rd of the Zhuang Nationality are outstanding representatives of Zhuang culture and have been listed as national intangible cultural heritage projects, they both have a solid foundation to apply for the world intangible cultural heritage, but they also face certain challenges. Therefore, the joint application of Guangxi Zhuang brocade and March 3rd of the Zhuang Nationality for the protection of the world intangible cultural heritage will not only realize complementary advantages, but also significantly improve the feasibility of successful project approval. In conclusion, it is a practical and strategic move for Guangxi Zhuang brocade and March 3rd of the Zhuang Nationality to jointly apply for the protection of the world intangible cultural heritage.

3.4 Guangxi Zhuang brocade of innovation

With the significant change of Guangxi Zhuang brocade use field, innovation has become a necessary way to adapt to the development needs of modern society. First of all, for the innovation of Guangxi Zhuang brocade, it is necessary to actively integrate fashion elements and combine fashion products in modern life with Zhuang brocade, so as to broaden the application scenarios of Zhuang brocade and realize its diversified application. Secondly, the traditional patterns or patterns of Guangxi Zhuang brocade should be deeply explored, and innovatively designed in the context of modern fashion, so as to give these patterns new vitality and cultural connotation. Third, attention should be paid to shaping the ceremonial use of Guangxi Zhuang brocade in the urban environment, so as to show the profound heritage and vitality of Guangxi Zhuang brocade inheritance. Finally, under the broad perspective of media communication in the new era, we should actively innovate the display mode of Guangxi Zhuang brocade, so as to broaden the development space of Zhuang brocade economy and culture.

3.5 Limitations of this study

The research value of Zhuang brocade is very significant, and its depth and breadth cannot be ignored. Each researcher's unique perspective and methodology, and the conclusions obtained are also diversified. This research is based on the extensive absorption and drawing on the research results of experts and scholars in the industry. However, the research path, conceptual framework and discussion content adopted are still difficult to fully show the whole picture and essence of Zhuang brocade culture. Furthermore, Guangxi Zhuang brocade, as an outstanding representative of local characteristic culture, is widely distributed and dispersed, which brings significant spatiotemporal challenges to the research work. In the process of this research, although brocade in Xincheng and Binyang have been selected as the key areas of field research, and conducted in-depth investigation and analysis, unfortunately, due to the urgent time and geographical conditions, we could not immediately go to Xincheng, Longzhou, Huanjiang and other sites that also have important research value for research. Therefore, in the future research process, it will be my bounden duty and mission to continuously pay attention to and deeply explore the rich connotation and unique charm of Zhuang brocade culture. Committed to making up for the shortcomings of the current research, through more comprehensive and in-depth field research and theoretical analysis, to contribute their own strength to reveal the whole picture of Zhuang brocade culture.

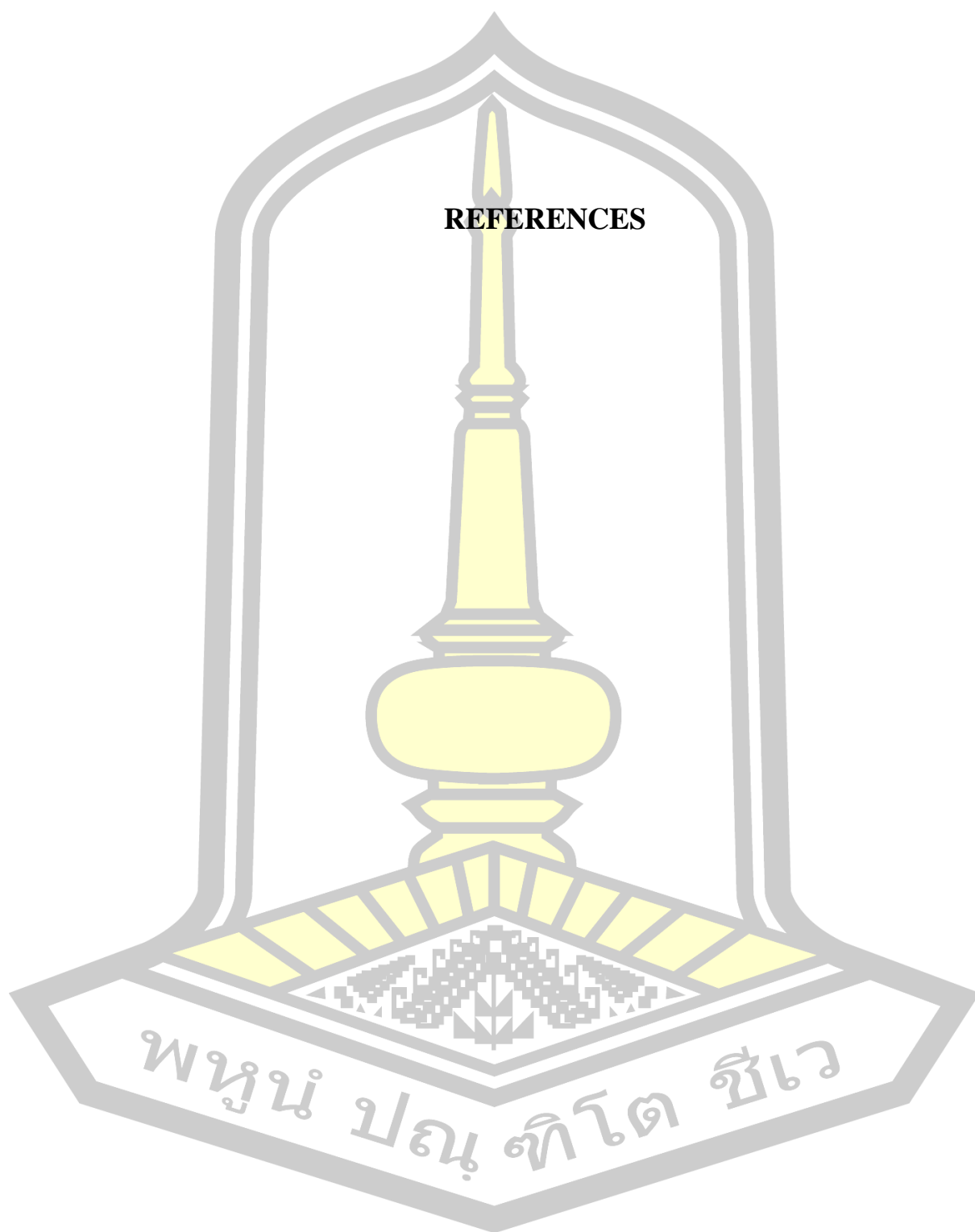
3.6 Article new knowledge discovery

First, the development of Guangxi Zhuang brocade is related to the social and historical development of the Zhuang people in Guangxi, and is closely related to the specific social environment such as economy, culture, totem, belief and customs. Is in the long-term historical action and accumulation, formed a complete and rich zhuang brocade culture system.

second, Guangxi Zhuang brocade The two forces of thousands of years of inheritance, First, with the ingenuity of the Zhuang women, Make the Guangxi Zhuang brocade pattern and totem and faith worship closely linked; Second, Guangxi Zhuang brocade works closely with the important life rituals of the Zhuang people, Constructing the important value and significance of Zhuang brocade in folk customs, So Guangxi Zhuang brocade is gathering the wisdom of the Zhuang people, Is the crystallization of the material and spiritual wealth of the Zhuang people, It has more important historical and research value.

Third, since China's reform and open to the outside world, the development of Guangxi Zhuang brocade has faced unprecedented and severe challenges. Due to the gradual decline of the native ecological environment and the field of survival. Guangxi Zhuang brocade Art was officially listed as a national intangible cultural heritage in 2006, which prompted us to re-examine and explore the survival field of Guangxi Zhuang brocade. In this context, Guangxi Zhuang brocade was forced to set foot on the road of "traditional invention", which was carefully shaped as the representative symbol of Guangxi and Zhuang culture, and became the spiritual sustenance of the Zhuang people's pursuit of a better life. At the same time, it also opens up a very effective path for the productive protection and live inheritance of Guangxi Zhuang brocade.

Fourthly, "March 3rd of the Zhuang Nationality · Bagui Carnival" is a typical phenomenon of "tradition being invented", which contains extremely rich research value. Through the active advocacy and promotion of the government, the event has successfully created a grand celebration of inclusiveness, fashion and national nature. This event not only deeply demonstrated the recognition and display of the common culture of the people of all ethnic groups in Guangxi, but also constructed a series of ceremonies to strengthen the social memory through the carefully planned organization and implementation process of the activities. These ceremonies clearly reflect the deep recognition and close interaction between the government, various folk intangible cultural heritage projects in Guangxi and the people of all ethnic groups in Guangxi. Therefore, this paper specially selects "March 3rd of the Zhuang Nationality · Bagui Carnival" as the analysis unit for in-depth discussion.



REFERENCES

พหุจน์ ปณฺ ทิโต ชีเว

- Bai, F. L. (2006). *Technology and gender: The power dimensions of late qing dynasty china*. Nanbrocadeg: Jiangsu People's Publishing House.
- Bao, Q. (1987). The splendor of brocadegxi brocade. *Ethnic Art*, (4), 135-138.
- brocade, S. P. (2006). Yunnan Minority Women and Traditional Textile Culture. *Journal of Yunnan Nationalities Institute*, 2006(6).
- Cai, R. X. (2016). Construction of zhuang brocade and multinational aesthetic identity. *Journal of Guangxi University for Nationalities*, 31(4), 5-9.
- Chao, R., & Zhao, Y. (2010). The transmission of Zhuang brocade. *Song Ocean*, (05), 123.
- Chen, J. J. (2008). *History of astronomy among chinese ethnic minorities*. Beibrocadedg: China Science and Technology Press.
- Chen, L. (2018). Research on the inheritance and development of zhuang brocade weaving skills. *Art Panorama*, 10, 82-83.
- Chen, L. (2018). Research on the inheritance and development of zhuang brocade weaving skills. *Jilin Fine Arts Publishing House*. pp. 46-47.
- Chen, W. (2003). Brief report on the excavation of shijiaoshan site in pingnan county, guangxi. *Archaeology*, (01), 15-21.
- Chen, W., & Yang, H. (2008). Research on the protective tourism development of zhuang brocade in guangxi. *Journal of Guilin Aerospace Industry College*, 13(04), 63-66.
- Chen, W., & Yang, H. (2009). Research on protective tourism development of "Zhuang brocade" in guangxi. *Journal of Nanning Normal College*, 26(01), 15-19.
- Chen, X. B. (1998). An archaeological investigation into the appearance time of the zhuang bull worship. *Guangxi Ethnic Studies*, (4), 32-37.
- Chen, X. R. (1981). Visiting japanese children's literature writer kusashima hisako. *Children's Literature Research*, 8, 159-160.
- Chen, Y. J. (1999). Ethnic weaving in guangxi. *Jiangsu Textile*, (Z1), 54-55.
- Chen, Y. S. (2019). Research on "shu brocade pu". *Decoration*, 2019(12), 104-108.
- Chinese Ethnic Minorities Revision Editorial Committee. (2009). *Chinese ethnic minorities*. China: Ethnic Publishing House.
- Chu, X., & Lv, J. (2021). Research on the evolution of Zhuang brocade weaving techniques. *Decoration*, (09), 107-111.
- Condon, P. (2000). *How societies remember*. Shanghai: Shanghai People's Publishing.
- Ding, Z. C. (2013). Productive protection of minority intangible cultural heritage from the perspective of ethnic cultural industry: A case study of zhuang brocade weaving technique. *Yunnan Social Sciences*, 2013(05), 100-105.
- Editorial Committee of the Lingnan Library., & Guangdong Chinese Ethnic Culture Promotion Association. (2010). *Collected annotations on records of unusual phenomena*. China: Guangdong People's Publishing House.
- Fan, C. (1984). *Guihai yuheng zhi [revised edition]*. Nanning: Guangxi Minzu Publishing House.
- Fan, D., & Gao, C. (2021). Zhuang brocade techniques and inheritance. *Engineering Research - Interdisciplinary Perspectives in Engineering*, 13(02), 107-117.

Fan, D., & Wan, F. (2018). The dilemma and way out of revitalizing traditional crafts in ethnic minority areas: A case study of zhuang brocade. *Journal of Guangxi University for Nationalities: Natural Science Edition*, 24(4), 45-51.

Fan, M. M. (2015). Protection and inheritance of intangible cultural heritage in industrial research and development: A case study of zhuang Brocade in guangxi. *Journal of Wuhan Textile University*, 28(1), 36-39.

Fan, M. M., & Zheng, L. (2015). Construction of female consciousness in ethnic brocade art. *Journal of Guangxi University for Nationalities (Philosophy and Social Science Edition)*, 32(5), 31-35.

Fan, X. J., & Wang, J. J. (2011). Construction of ethnic cultural symbolization and cultural ecological space: A case study of zhuang brocade. *Journal of Wuzhou University*, 21(4), 43-48.

Fang, S. M. (2022). Constructing the vibrant practice of the common spiritual home of the chinese nation—innovation and development of "zhuang nationality march 3rd" in guangxi. *Guangxi Ethnic Studies (05)*, 1-10.

Feng, H. L. (1948). Records of brocade in Guangxi County.

Fu, G. N. (2013). *Exploration on the development and utilization of zhuang brocade*. In Memory + Creativity = Social Change: Proceedings of the Sixth Academic Symposium of the Guangxi Zhuang Autonomous Region Museum (pp. 203-207).

Gao, S. (2007). Five lyrics by Gao Shouxin. *Lyrics Magazine*, (10), 49+1.

Gao, X., et al. (2019). Promoting ethnic spirit and demonstrating cultural confidence - research and thinking on building the cultural tourism consumption brand of "zhuang nationality march 3rd · bagui carnival". *Contemporary Guangxi*, 4.

Gran, S. (1983). *Issues in art*. Beibrocade: China Social Sciences Press.

Guangxi brocade in Guangxi County Records Compilation Committee. (2000). *brocade in Guangxi County annals*. Nanning: Guangxi People's Publishing House.

Guangxi Local Chronicles Compilation Committee. (2000). *Textile industry chronicle of Guangxi Zhuang Autonomous Region*. Guangxi People's Publishing House.

Guangxi Zhuang Autonomous Region Editorial Group. (1984). *Social history survey of Guangxi (Volume 1)*. China: Guangxi Ethnic Publishing House.

Guangxi Zhuang Autonomous Region Museum. (1988). *Han tombs in Luopo Bay, Guigang, Guangxi*. Beibrocade: Cultural Relics Press.

Guo, Wei. (2001). *Collection of Chinese folk stories: Guangxi volume*. China: China ISBN Center Publishing.

Habwach, M. (2002). *On collective memory*. Shanghai: Shanghai People's Publishing.

He, D. C. (1987). Zhuang brocade in Guangxi. *Silk*, 7, 52.

He, D. C. (1997). Guangxi zhuang brocade. *Jiangsu Silk*, 1997(02), 25.

He, J. W., & Gao, Y. L. (2010). Research on the development, evolution, and inheritance of ethnic handicrafts as intangible cultural heritage—a case study of zhuang brocade in Guangxi. *Qinghai Nationalities Studies*, 21(03), 147-151.

Hobsbawm, E., & Lang, T. (2020). *Traditional inventions*. Nanbrocade: Yilin Publishing House.

Hobsbawm, E., & Ranger, T. (2020). *The invention of tradition*. Nanbrocade: Yilin Publishing.

- Huang, B. H., & Deng, S. (2013). *Three collections of art series, Volume Five*. Hangzhou: Zhejiang People's Fine Arts Publishing House, 247-254.
- Huang, R. B. (2012). Analysis of the Inheritance and Development Path of Zhuang Culture. *Journal of Qingyuan Vocational and Technical College*, 5(2), 46-50.
- Huang, X. F. (1988). *A general history of the zhuang people*. China: Guangxi Nationalities Publishing House.
- Huang, Y. Z., & Ye, N. X. (1988). Excavation report on the wuming matou'an and other yangshan warring states tombs in guangxi. *Cultural Relics*, (12), 14-22.
- Huang, Z. Y. (2020). Reflections on the development, evolution, and inheritance of zhuang brocade weaving skills. *Reform and Opening Up*, Z3, 15-18.
- Institute of Archaeology, Chinese Academy of Social Sciences, et al. (2003). *Zhengpiyan in guilin*. Beibrocadeg: Cultural Relics Press.
- Institute of Archaeology, Chinese Academy of Social Sciences. (2003). *Zhengpiyan in guilin*. Beibrocadeg: Cultural Relics Press.
- Jia, D. X. (2021). Analysis of productive protection of intangible cultural heritage: A case study of zhuang brocade weaving technique. *Popular Science*, 23(05), 151-155.
- Jiang, T., & Wei, R. (1978). The warring states tomb at yingshanling, pingde. *Journal of Archaeology*, (02), 211-258+273-284.
- Jin, S., & Wang, L. (2014). Zhuang brocade. *Song Ocean*, (03), 125-126.
- Kuang, L. (1935). *Chiyu*. Shanghai: Commercial Press.
- Lan, H. E., & Wang, S. (1990). *Dictionary of religions and myths of various ethnic groups in China*. China: Xueyuan Publishing House.
- Lan, S. W. (2019). *Zhuang brocade woven into memory*. China: Binyang Daily.
- Li, F. Q., (2018). *A tribute to spring: Zhuang march 3rd song festival*. Nanning: Guangxi People's Publishing House.
- Li, G. X., & Hua, J. (2007). *Impressions: A new perspective on the cultural industry of liu sanjie*. China: Shanghai Literary Arts Publishing House.
- Li, J. (2010). The world's largest zhuang brocade presented at the world expo. *Guangming Daily*, p. 7.
- Li, K. R. (1985). Qingwa gehui. *Guangxi Daily*.
- Li, P. (2014). Research on the development of aesthetic value of intangible cultural heritage in baise city: Based on the perspective of brocadegxi zhuang brocade technology. *Journal of Baise College*, 27(6), 90-97.
- Li, X. L. (2009). Reflections on the educational function and inheritance countermeasures of zhuang brocade from the perspective of educational Anthropology. *Academic Theory*, 2009(06), 187-188.
- Li, X. P. (2010). Guangxi weaves giant zhuang brocade to apply for "guinness world records". *Guangxi Daily*, p. 11.
- Liang, J., & Zheng, Y. (2012). Analysis of industrial operation of arts and crafts in guangxi. *Journal of Guangxi University (Philosophy and Social Sciences Edition)*, 34(4), 19-23+28.
- Liang, T., (2000). *"An introduction to zhuang culture"*. China: Guangxi Education Press.
- Liao, M, J., & Lu, C. (2012). *The culture of weaving and embroidery in guangxi*. Nanning: Guangxi People's Publishing House.

Liao, M. J. (2002). *Worship culture of nature among the zhuang ethnic group*. Nanning: Guangxi People's Publishing House.

Lin, X. N. (2013). Where is the future of fading colorful brocade? *Guangxi Daily*, p. 009.

Liu, H. J. (2007). Zhuang brocade: Colorful embroidery of china. *China Quality Journey*, 2007(03), 74-75.

Liu, L., & Wang, Z. (2007). Zhuang brocade ballads. *Songs*, (07), 28-29.

Liu, T. Y. (2005). An overview of zhuang brocade weaving. *Folklore Studies*, 2005(01), 217-222.

Liu, Z. (1995). *Women in the ocean of songs*. Kun Ming: Yunnan Education Publishing House.

Liu, Z. Z. (2012). Composition of modern clothing colors from the perspective of zhuang brocade colors in guangxi. *Journal of Nanning Vocational and Technical College*, 17(04), 16-19.

Lu, C. Y. (2021). Inheritance and innovation of intangible cultural heritage in traditional minority crafts: A case study of gengdan zhuang brocade technique in sili village. *Design*, 34(05), 119-121.

Lu, N., & Zhang, J. J. (2020). New classical "structure-function theory": Experience and inspiration of intangible cultural heritage traditional ethnic skills helping accurate poverty alleviation in ethnic areas. *Journal of Guizhou Minzu University (Philosophy and Social Sciences Edition)*, (03), 87.

Lu, Q. (2017). *Research on Zhuang brocade patterns* (Unpublished doctoral dissertation). Jinan: Shandong University.

Lu, X., (2005). "What is 'ge xiu'—the concept and folk expression of 'ge xiu' in the perspectives of literati and scholars". *Guangxi Ethnic Studies*, 4.

Luo, M., & Xu, K. (2020). Investigation and development research on tourism resources in guangxi meinv village. *Journal of Liupanshui Normal College*, 06, 31-36.

Luo, X. (2016). *Research on the cultural industry development of "zhuang nationality march 3rd" in guangxi*. China: Shanxi Economic Publishing House.

Luo, X., (2019). Strategic research on the synergetic development of ethnic cultural industry and minority rural tourism: A case study of the "zhuang nationality march 3rd, bagui carnival" cultural tourism brand. *Agricultural Economy*, 6, 80.

Lu, D. F. (2006). *brocade guan lou ji*. China: Shanghai Lexicographical Publishing House.

Ma, H. (2007). Aesthetic evaluation and protection and development of zhuang brocade art. *Art Observation*, 2007(07), 122-123.

Ma, L., & Wu, W. (2012). Zhuang brocade in the heart. *Song Ocean*, (05), 118.

Mai, Z., & Fu, Q. (1999). A piece of beautiful Zhuang brocade. *Song Ocean*, (01), 6-7.

Mao, Q. (2020). The popularization practice of folk literature—On the collection and research of folk literature by Xiao Ganniu. *Journal of Gannan Normal University*, 41(4), 58-62.

Mo, J. (1984). *Guangxi scenery records*. China: Guangxi People's Publishing House.

Mo, L. (2023). Appreciating the feast of ethnic culture and composing poems for a better life. *Nanning Daily*, p.4.

Ning, Q. L. (2010). *The generation and modern reconstruction of zhuang brocade cultural symbols (Doctoral dissertation)*. Guilin: Guangxi Normal University.

Ning, Q. L.(2010). Zhuang brocade: Construction of a cultural symbol and contemporary representation. *Journal of Liuzhou Teachers College*, 25(3), 8-12.

Nong, W. J. (2017). The culture of zhuang brocade in brocadegxi and its ecological environment. *Journal of Nanning Vocational and Technical College*, 22(6), 97-100.

Pan, F. W. (2012). Reflections on the inheritance, protection, and development of xincheng zhuang brocade. *Popular Science and Technology*, (12), 183-185.

Pan, L., (2018). *Research on the modern transformation of ritual communication in zhuang song markets*. Master's Thesis, South-Central University for Nationalities.

Pan, Q. X., & Qin, N. C.(1993). *Encyclopedia of the zhuang ethnic group*. China:Guangxi People's Publishing House.

Peng, Y. (2011). Analysis of aesthetics of zhuang brocade. *Journal of Liuzhou Teachers College*, 26(02), 4-7+18.

Qian, X. P. (2014). *Complete collection of chinese brocade*. China: China Textile Press.

Qian, X. Q. (2014). *Complete works of chinese brocade*. China: China Textile Press

Qin, C. L. (1990). A brief discussion on zhuang natural worship. *In Guangxi Ethnic Studies*, 4.

Qin, G. Q. (1990). *The history of tusi in xincheng*. Nanning: Guangxi Ethnic Publishing House.

Qin, N. C., & Pan, Q. X. (1995). *Collection of zhuang studies*. Nanning: Guangxi Ethnic Publishing House.

Qin, X. H. (1993). "The 'six crows holy mother': Prototype of bird deity worship in the zhuang ethnic group." *Guangxi Ethnic Studies*, (3), 79-83.

Shi, C. (1978). On the origin of the zhuang ethnic group. *Academic Forum*, (01), 117-121.

Shi, X. R. (2022). A study on the cultural genes and inheritance of zhuang brocade. (Master's thesis). South-Central University for Nationalities.

Si, M. Q. (1975). *Records of the grand historian*. Beibrocadeg: Zhonghua Book Company,.

Sun, D., & Wang, F. (2006). On the historical types of social memory. *Hubei Social Sciences*, 12, 126-128.

Sun, Q. C., (2018). "The 'National Inheritance' of Intangible Cultural Heritage from the Perspective of 'Zhuang Nationality March 3' in Guangxi". *China Art Times*, 6.

Susan Grant. (1983). *Art issues*. Beijing: China Social Sciences Press.

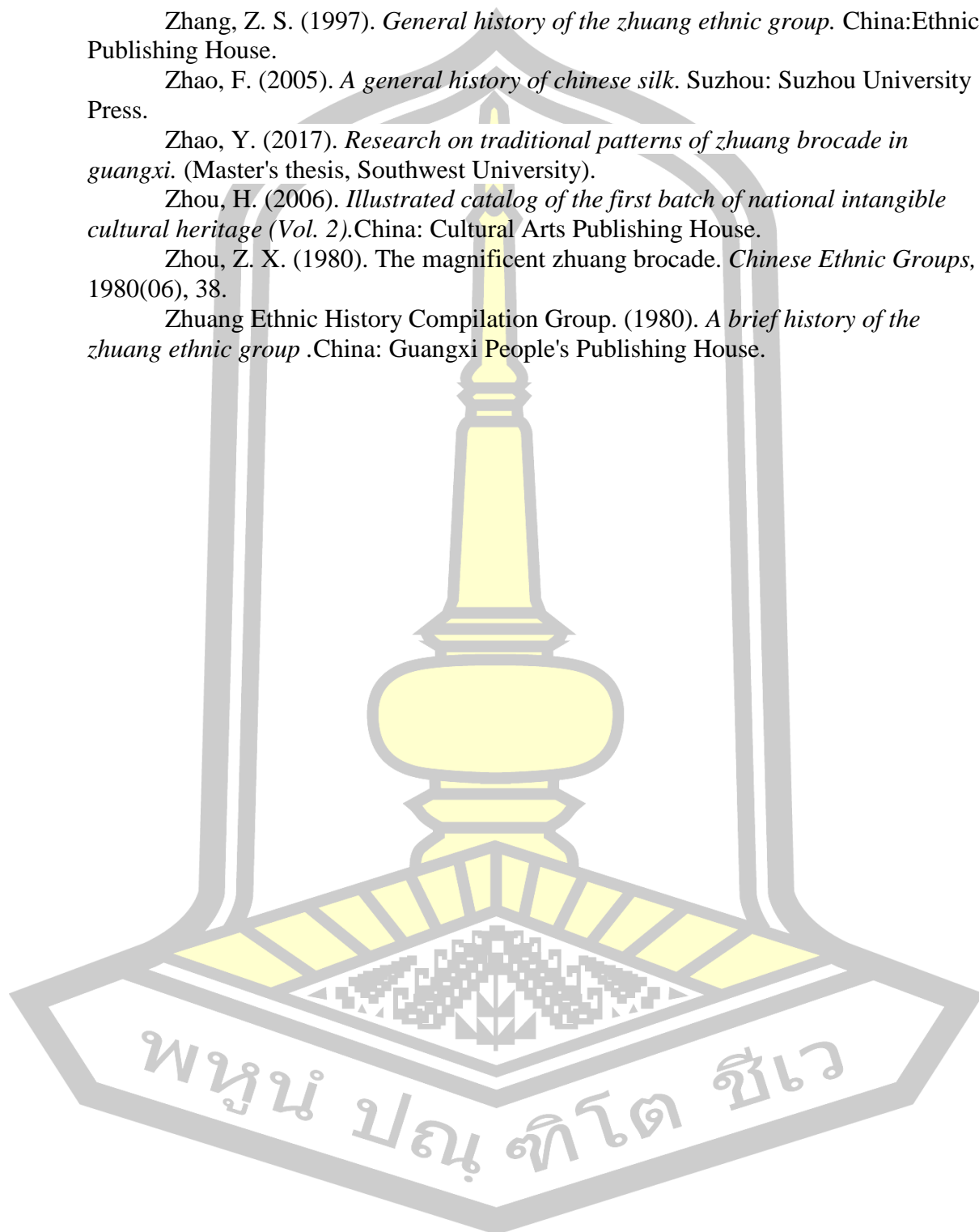
Tan, G. Q. (1990). *The history of xincheng tusi*. China: Guangxi Ethnic Publishing House.

Tan, L. P., Liu, H. X., & Chen, L. (2012). Research on Zhuang Brocade Weaving Technology in Guangxi. *Silk*, 2012, 49(01), 48-51.

- Tan, X. F. (1980). The charm of poetry and painting in brocade (prose). *Journal of Guangxi University for Nationalities (Social Sciences Edition)*, 1980(01), 115-116+119.
- Tan, Y. (2010). Inheritance and development of Zhuang brocade. *Mass Art*, (15), 136-137.
- Tang, J. (2010). Weaving and application of Zhuang brocade in Guangxi. *Literary Controversy*, (22), 122-124.
- Tang, Y. (2010). The inheritance and development of zhuang brocade. *Popular Literature and Art*, 2010(15), 136-137.
- Tao, W. P. (1984). Zhuo brocade, weaving patterns of the times: On the ethnic characteristics of zhuang poet sha hong's poetry. *Ethnic Literature Studies*, 1984(03), 13-20.
- Tuo, T., et al. (1977). *History of the song dynasty, volume 153: Miscellaneous subjects and dress regulations, part five: Clothing of various officials, part two*. China: Zhonghua Book Company.
- Wan, Z. (1960). *Nan prefecture's record of unusual phenomena*. China: Zhonghua Book Company.
- Wang, L. X., et al. (2019). Analysis and research on zhuang cultural elements in the animated film "A zhuang brocade". *Drama Home*, 2019(02), 119.
- Wang, Y. (1984). Minority art films produced in China. *Film Review*, 1984(06), 28.
- Wang, Y. (2023). *Ecological aesthetics research of "Zhuang Nationality March 3rd" in Guangxi*. (doctoral dissertation). Guangxi University for Nationalities.
- Wang, Z. (2017). Exploration of the connection between the development of zhuang brocade technology and equipment. *Technology and Field*, 24(7).
- Wehler, H. (2007). *Social memory: History, recollection, inheritance*. Beibrocadedg, China: Peking University Press.
- Wei, D. F., et al. (2017). *Research and inheritance of traditional techniques in guangxi*. Hefei: Anhui Science and Technology Press.
- Wu, D. (2021). Protection and innovation: A study on the creative transformation of zhuang brocade from the perspective of intangible cultural heritage. *Journal of Hechi College*, 2021, 41(01), 25-31.
- Wu, H. (1986). Preliminary exploration of the origin of geometric patterns in zhuang brocade. *Guangxi Ethnic Studies*, 1986(01), 79-87+78.
- Wu, S. Q. (2022). Appreciating "poetry of ma le patterns". *New Reading*, 07, 65-66.
- Wu, W. (1990). Zhuang brocade technology of guangxi zhuang autonomous region. *Guangxi Ethnic Studies*, 1990(03), 50-55.
- Wu, W. (2014). *Zhuang brocade craftsmanship*. Beibrocadedg: Beibrocadedg Science and Technology Press.
- Wu, W. (2018). *Zhuang brocade*. Nanning: Guangxi Fine Arts Publishing House.
- Wu, W. F. (2022). A discussion on zhuang brocade patterns. *Art and Folk Customs*, 2022(04), 73-82.
- Wu, W. F., & Cai, H. (2018). *Zhuang brocade*. China: Guangxi Fine Arts Publishing House.

- Wu, Y. (2011). Discussion on traditional handicrafts of zhuang brocade in guangxi and its development space in modern society. *In Museum and Memory: Proceedings of the Fourth Academic Seminar of the Guangxi Zhuang Autonomous Region Museum* (pp. 259-265).
- Xiao, G. N. (1955). A zhuang brocade. *Folk Literature*, 1955(1), 18-21.
- Xiao, G. N. (1958). A zhuang brocade: A guizhou opera. *Nanning: Guangxi People's Publishing House*, pp. 1-46.
- Xie, Y. L. (2005). Authorship examination of "suihua jili pu", "jianzhi pu", and "shu brocade pu". *Chinese Cultural Forum*, 2005(02), 21-26.
- Xincheng County Chronicle Editorial Board. (1997). *Xincheng County Chronicle*. China: Guangxi People's Publishing House.
- Xu, G. (2014). Shortcomings and possible solutions for the productive protection of intangible cultural heritage: A case study of zhuang brocade practice. *Journal of Southwest Minzu University (Humanities and Social Sciences Edition)*, 2014, 35(09), 8-13.
- Xu, X. (2016). *A Study on traditional textile crafts of the zhuang people and their culture*. Doctoral Dissertation, Donghua University.
- Xu, X. M., (2018). "From ethnic identity to cultural sharing: Changes in zhuang march 3rd since the 1980s". *Journal of Guangxi Normal University for Nationalities*, 6.
- Yan, X. (2021). Research on the high-quality development of intangible cultural heritage industry: A case study of zhuang brocade industry. *Journal of Nanning Normal University (Philosophy and Social Sciences Edition)*, 2021, 42(01), 32-42.
- Yan, Y., (2020). Identity and inheritance: Intercollegiate cultural interaction activities of 'zhuang nationality march 3' festival. *Journal of Higher Education*, 8.
- Ye, X. (2011). Aesthetic reflections on the large-scale dance drama Zhuang Brocade. *Popular Literature and Art*, (03), 150.
- Yin, H. (2010, May 28). Our region's achievements at the "Nine Arts Festival". *Guangxi Daily*, p. 002.
- Yu, S. J. (1992). Discussion on zhuang brocade culture. *Journal of Guangxi University (Philosophy and Social Science Edition)*, 1992(04), 44-48.
- Zeng, X., & Lan, Q. (2003). Zhuang brocade on Longji. *Song Ocean*, (01), 30.
- Zhang, A. (2006). An analysis of the current situation of Zhuang brocade in Binyang, Guangxi. *Decoration*, (08), 34.
- Zhang, H., & Huang, Z. (1996). Beautiful Zhuang brocade of Ba Gui. *Song Ocean*, (03), 18-19.
- Zhang, J. M. (2013). The ethnic cultural connotation of zhuang brocade patterns. *Art Exploration*, (4), 51-53.
- Zhang, L. (2010). An analysis of development strategies for the Zhuang brocade industry in Guangxi. *Today's South China (Theoretical Innovation Edition)*, (03), 123-124.
- Zhang, L. (2010). Analysis of the development strategy of zhuang brocade industry in guangxi. *Today's South China (Theoretical Innovation Edition)*, 2010(03), 123-124.
- Zhang, M., & Fu, K. (2014). Zhuang brocade hanging in the sky. *Song Ocean*, (02), 124.

- Zhang, M., & Huang, C. (2013). Zhuang brocade. *Music Creation*, (04), 13-15.
- Zhang, Z. S. (1997). *General history of the zhuang ethnic group*. China: Ethnic Publishing House.
- Zhao, F. (2005). *A general history of chinese silk*. Suzhou: Suzhou University Press.
- Zhao, Y. (2017). *Research on traditional patterns of zhuang brocade in guangxi*. (Master's thesis, Southwest University).
- Zhou, H. (2006). *Illustrated catalog of the first batch of national intangible cultural heritage (Vol. 2)*. China: Cultural Arts Publishing House.
- Zhou, Z. X. (1980). The magnificent zhuang brocade. *Chinese Ethnic Groups*, 1980(06), 38.
- Zhuang Ethnic History Compilation Group. (1980). *A brief history of the zhuang ethnic group*. China: Guangxi People's Publishing House.



APPENDIX

1. Fieldwork Facts of Yao Cheng Tian

Time	Fieldwork locations	On-site work photos
December 2022	Tian Yao Cheng to brocadegxi Zhuang Brocade Factory Field Survey	
April 2023	Tian Yao Cheng's Fieldwork at brocadegxi Zhuang Museum	
April 2023	Tian Yao Cheng curates the series of activities of March 3 of the Zhuang Nationality - Bagui Carnival - "Embroidery Empowers Cultural Revitalization - brocadegxi Zhuang Brocade, Pile Embroidery and Embroidery Cultural Exhibition".	

April 2023 Tian Yao Cheng's Fieldwork at brocadegxi brocade Yuan



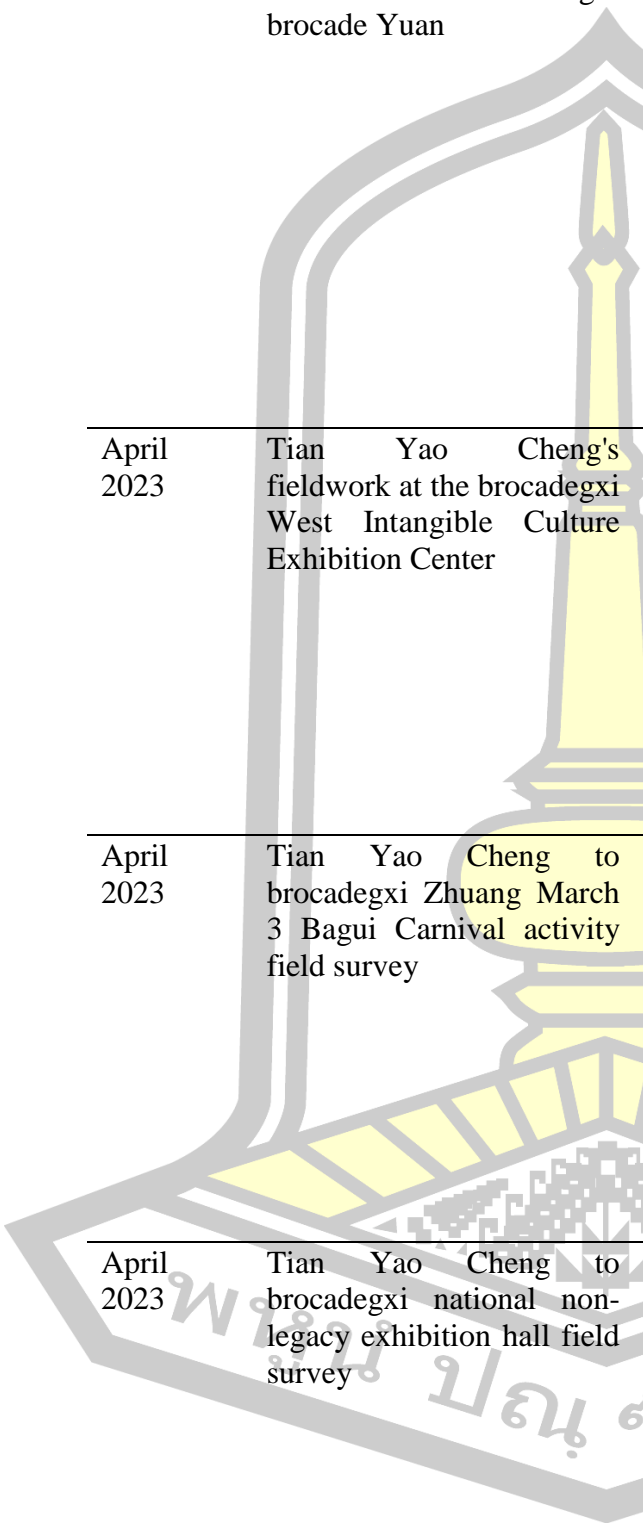
April 2023 Tian Yao Cheng's fieldwork at the brocadegxi West Intangible Culture Exhibition Center



April 2023 Tian Yao Cheng to brocadegxi Zhuang March 3 Bagui Carnival activity field survey



April 2023 Tian Yao Cheng to brocadegxi national non-legacy exhibition hall field survey



November 2023 Fieldwork at Xiangguang Studio in Nanning by Tian Yao Cheng



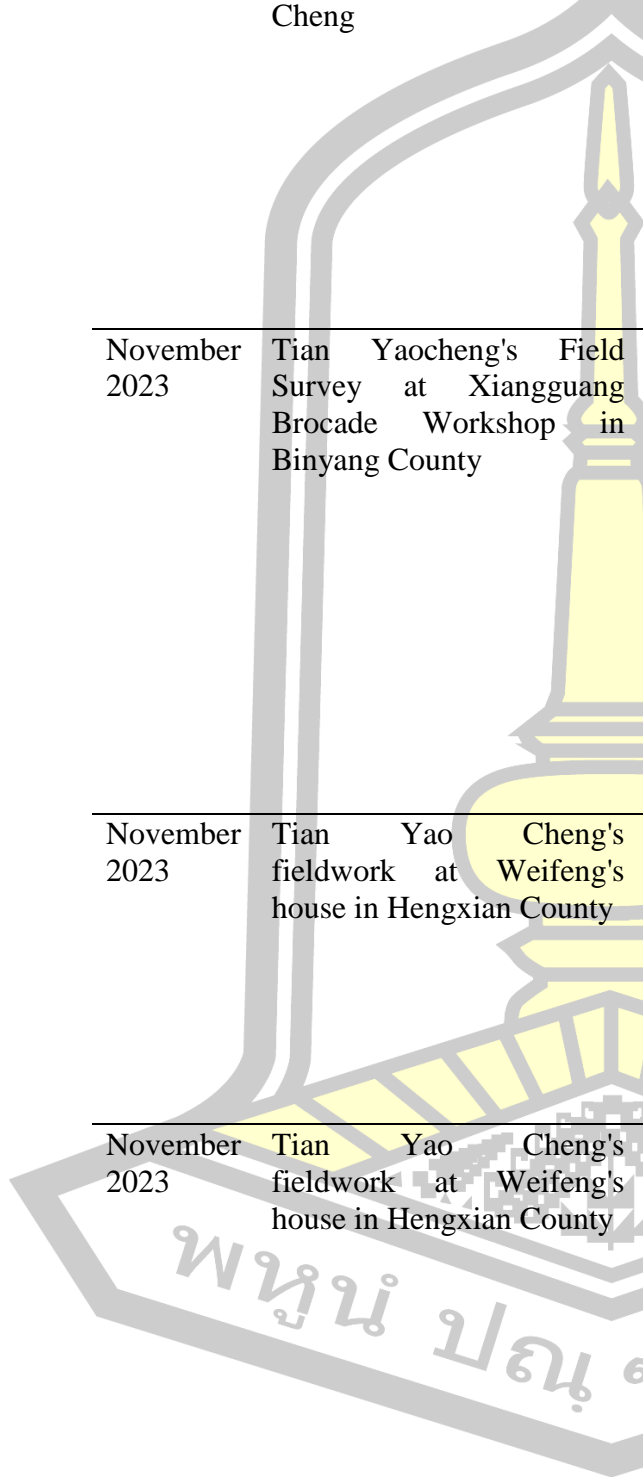
November 2023 Tian Yaocheng's Field Survey at Xiangguang Brocade Workshop in Binyang County



November 2023 Tian Yao Cheng's fieldwork at Weifeng's house in Hengxian County



November 2023 Tian Yao Cheng's fieldwork at Weifeng's house in Hengxian County



2. Outline of the interview

2.1 Guangxi Zhuang brocade Interview outline

For the people: the inheritors of Zhuang brocade

Interviewer: Name:_____, Interview time:_____, Interview place:_____。

Subject: Name:_____, sex:_____, age:_____, nation:_____, post:_____, work unit:_____。

1.1.1 Are you the inheritor of zhuang brocade skills?

1.1.2 If so, can you share your experience of learning zhuang brocade skills? Such as the process of learning, skills teaching, pattern design, innovation and invention and other information.

1.1.3 Has your family or business ever been engaged in the traditional zhuang brocade production? If so, how do they retain this traditional craft.

1.1.4 What are the changes in the use and significance of the past and the modern zhuang brocade in the contemporary society? What impact do these changes have on Zhuang brocade?

1.1.5. What is the role of modern Zhuang brocade in the process of modern society? What is the meaning?

1.1.6 As an inheritor, how will you pass on this traditional skill?

1.1.7 Do you think whether the process of invention invented the art or the pattern, what is the significance of these two for the current inheritance of Zhuang brocade?

1.1.8, Will you integrate Zhuang brocade into modern design? If so, what are your ideas and suggestions?

1.1.9 In your opinion, how to promote and spread zhuang brocade culture to a wider group? What measures do you think can be taken in this regard?

1.1.10 How do you think to attract more young people to participate in the Zhuang brocade culture and combine the lifestyle of young people to arouse the new mission of Zhuang brocade?

1.1.11 Do you feel that your inheritance mission is more important? What specific actions do you take to protect and inherit the Zhuang brocade culture?

2.3.6 In your understanding, under the influence of the current cultural diversification, what is the impact on the development and inheritance of Zhuang brocade products?

2.3.7 How do you view the process of innovation and development of Zhuang brocade in your research process?

2.3.8 Do you think that in the process of promoting and developing the zhuang brocade culture, is the invention of the traditional zhuang brocade applicable to the modern and fashionable design techniques?why?

2.3.9 What problems and suggestions do you think you should pay attention to in the process of being invented?

2.3.10 In your opinion, what problems and challenges should Zhuang brocade pay attention to in the process of protecting and inheriting Zhuang brocade culture after it becomes a national intangible cultural heritage?

2.3.11 In your work and research, what ideas and suggestions do you have that can help you better develop and inherit the Zhuang brocade culture?

BIOGRAPHY

NAME	Yaocheng Tian
DATE OF BIRTH	February 12, 1989
PLACE OF BIRTH	Hebei, China
ADDRESS	Baise College Chengbi Campus, Guangxi Zhuang Autonomous Region, China
POSITION	Lecturer in higher education
PLACE OF WORK	Baise College
EDUCATION	2021 Master Degree, Major Artistics Graduated from Kirik University Master Degree, Major Artistics 2024 Doctor of Philosophy (Fine and Applied Arts Research and Creation), Faculty of Fine-Applied Arts and Cultural Science, Mahasarakham University

